

**Lee County Board Of County Commissioners  
Agenda Item Summary**

**Blue Sheet No. 20041033**

**1. REQUESTED MOTION:**

**ACTION REQUESTED:** Approve the award of the Purchase of a Generator for Fleet Management, to the low quoter meeting all specification requirements, Cummins Southeastern, Inc., for a grand total amount - including Option A - of \$73,034. Please note that this purchase is being made in accordance with the terms and conditions of Formal Quote No. Q-040331 which was Board approved on June 29, 2004.

**WHY ACTION IS NECESSARY:** Expenditures exceeding \$50,000 require Board approval.

**WHAT ACTION ACCOMPLISHES:** Will provide the Department of Fleet Management with a backup power source for the entire building. Savings to taxpayers: \$14,931.

**2. DEPARTMENTAL CATEGORY:  
COMMISSION DISTRICT #**

*CBK*

**3. MEETING DATE:**

*08-24-2004*

**4. AGENDA:**

- CONSENT
- ADMINISTRATIVE
- APPEALS
- PUBLIC
- WALK ON
- TIME REQUIRED:

**5. REQUIREMENT/PURPOSE:  
(Specify)**

- STATUTE
- ORDINANCE
- ADMIN. AC-4-1
- CODE
- OTHER

**6. REQUESTOR OF INFORMATION:**

- A. COMMISSIONER
- B. DEPARTMENT Fleet Management
- C. DIVISION

BY: Marilyn Rawlings, Director

**BACKGROUND:** Sealed quotations – in accordance with the terms and conditions of Formal Quote No. Q-040331 - were received by the Division of Purchasing on August 3, 2004. The three responses received have been thoroughly reviewed, and a recommendation is being made to award to Cummins Southeastern, Inc. as the low quoter meeting specifications. Total amount for the generator: \$73,034.

Funds are available: Account String – 20865318200.506410

**Please see attachments:**

- (1) Tabulation Sheet
- (2) Specifications
- (3) Cummins Southeastern's Quotation
- (4) Blue Sheet No. 20040772 – Board Approved 6/29/04

**8. MANAGEMENT RECOMMENDATIONS:**

**9. RECOMMENDED APPROVAL:**

A Department Director	B Purchasing or Contracts	C Human Resources	D Other	E County Attorney	F Budget Services				G County Manager
<i>[Signature]</i>	<i>[Signature]</i>			<i>[Signature]</i>	<i>[Signature]</i>	<i>[Signature]</i>	<i>[Signature]</i>	<i>[Signature]</i>	<i>[Signature]</i>
				<i>8/9/04</i>	<i>OA</i> <i>8/9/04</i>	<i>OM</i> <i>8/10/04</i>	<i>Risk</i> <i>8/10/04</i>	<i>GC</i> <i>8/19/04</i>	

**10. COMMISSION ACTION:**

- APPROVED
- DENIED
- DEFERRED
- OTHER

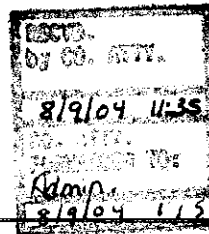

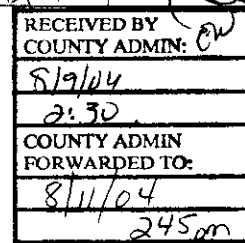

FORMAL QUOTATION #Q-040331

LEE COUNTY, FLORIDA TABULATION SHEET

OPENING DATE: 8/3/04

FOR

BUYER: BOB FRANCESCHINI

ANNUAL PURCHASE OF GENERATORS - THE PURCHASE OF A GENERATOR FOR FLEET

<b>VENDORS</b>	CUMMINS	PANTROPIC	FLORIDA DETROIT DIESEL -	
	SOUTHEASTERN POWER	POWER	ALLISON, INC	

ACKNOWLEDGE ADDENDUM (S)	YES	YES	YES	
GRAND TOTAL COST:	\$71,494.00	\$87,215.00	\$73,310.00	
ENGINE MANUFACTURER:	CUMMINS	CATERPILLAR 3406	DETROIT DIESEL CORP	
DELIVER WITH OWN VEHICLES?	YES	YES	NO	
DELIVERY - CALENDAR DAYS:	70	240	75-100	
OFFICE IN LEE COUNTY:	YES	YES	YES	
MODIFICATIONS:	NO	NO	NO	
QUOTE SIGNED?	YES	YES	YES	
OPTION A - WARRANTY	\$1,540.00	\$750.00	\$1,700.00	

<b>NO BIDS</b>				

ATTACHMENT 1



**LEE COUNTY**  
SOUTHWEST FLORIDA

PROJECT NO.: Q-040331

OPEN DATE: AUGUST 3, 2004

AND TIME: 2:30 P.M.

**\*\*\*MANDATORY/ON-SITE\*\*\***

PRE-BID DATE: JULY 26, 2004

AND TIME: 1:00 P.M.

LOCATION: LEE COUNTY FLEET MGMT  
2955 VAN BUREN STREET  
FORT MYERS, FL 33916

# REQUEST FOR QUOTATIONS

## TITLE:

## ANNUAL PURCHASE OF GENERATORS (GENERATOR FOR FLEET)

REQUESTER: LEE COUNTY BOARD OF COUNTY COMMISSIONERS  
DIVISION OF PURCHASING

**MAILING ADDRESS**

P.O. BOX 398  
FORT MYERS, FL 33902-0398

**PHYSICAL ADDRESS**

1825 Hendry St 3<sup>rd</sup> Floor  
FORT MYERS, FL 33901

BUYER: BOB FRANCESCHINI, C.P.M., CPPB  
PURCHASING AGENT  
PHONE NO.: (239) 344-5450

**GENERAL CONDITIONS**

Sealed Quotations will be received by the DIVISION OF PURCHASING, until 2:30pm on the date specified on the cover sheet of this "Request for Quotations", and opened immediately thereafter by the Purchasing Director or designee.

Any question regarding this solicitation should be directed to the Buyer listed on the cover page of this solicitation, or by calling the Division of Purchasing at (239) 344-5450.

1. **SUBMISSION OF QUOTE:**

- a. Quotations shall be sealed in an envelope, and the outside of the envelope should be marked with the following information:
  - 1. Marked with the words "Sealed Quote"
  - 2. Name of the firm submitting the quotation
  - 3. Title of the quotation
  - 4. Quotation number
  
- b. The Quotation shall be submitted in triplicate as follows:
  - 1. The original consisting of the Lee County quotes forms completed and signed.
  - 2. A copy of the original quote forms for the Purchasing Director.
  - 3. A second copy of the original quote forms for use by the requesting department.
  
- c. The following should be submitted along with the quotation in a separate envelope. This envelope should be marked as described above, but instead of marking the envelope as "Sealed Quote", please indicate the contents; i.e., literature, drawings, submittals, etc. This information should be submitted in duplicate.
  - 1. Any information (either required or in addition to that asked for by the specifications) necessary to analyze your quotation; i.e., required submittals, literature, technical data, financial statements.
  - 2. Warranties and guarantees against defective materials and workmanship.
  
- d. **ALTERNATE QUOTE:** If the vendor elects to submit more than one quote, then the quotes should be submitted in separate envelopes and marked as indicated above. The second, or alternate quote should be marked as "Alternate".

- e. **QUOTES RECEIVED LATE:** It is the quoter's responsibility to ensure that his quote is received by the Division of Purchasing prior to the opening date and time specified. Any quote received after the opening date and time will be promptly returned to the quoter unopened. Lee County will not be responsible for quotes received late because of delays by a third party delivery service; i.e., U.S. Mail, UPS, Federal Express, etc.
- f. **QUOTE CALCULATION ERRORS:** In the event there is a discrepancy between the total quoted amount or the extended amounts and the unit prices quoted, the unit prices will prevail and the corrected sum will be considered the quoted price.
- g. **PAST PERFORMANCE:** All vendors will be evaluated on their past performance and prior dealings with Lee County (i.e., failure to meet specifications, poor workmanship, late delivery, etc.).
- h. **WITHDRAWAL OF QUOTE:** No quote may be withdrawn for a period of 90 days after the scheduled time for receiving quotes. A quote may be withdrawn prior to the quote-opening date and time. Such a request to withdraw should be made in writing to the Purchasing Director, who will approve or disapprove of the request.
- i. **COUNTY RESERVES THE RIGHT:** The County reserves the right to waive minor informalities in any quote; to reject any or all quotes with or without cause; and/or to accept the quote that in its judgment will be in the best interest of the County of Lee.
- j. **EXECUTION OF QUOTE:** All quotes shall contain the signature of an authorized representative of the quoter in the space provided on the quote proposal form. All quotes shall be typed or printed in ink. The bidder may not use erasable ink. All corrections made to the quote shall be initialed.

2. **ACCEPTANCE**

The materials and/or services delivered under the quote **shall** remain the property of the seller until a physical inspection and actual usage of these materials and/or services is accepted by the County and is to be in compliance with the terms herein, fully in accord with the specifications and of the highest quality. In the event the materials and/or services supplied to the County are found to be defective or do not conform to specifications, the County reserves the right to cancel the order upon written notice to the seller and return such product to the seller at the seller's expense.

3. **SUBSTITUTIONS**

Whenever in these specifications a brand name or make is mentioned, it is the intention of the County only to establish a grade or quality of materials and not to rule out other brands or makes of equality. However, if a product other than that specified is quote, it is the vendor's responsibility to name such product with his quote and to prove to the County that said product is equal to the product specified. Lee County **shall** be the sole judge as to whether a product being offered by the quoter is actually equivalent to the one being specified by the detailed specifications. (Note: This paragraph does not apply when it is determined that the technical requirements of this solicitation require only a specific product as stated in the detailed specifications.)

4. **RULES, REGULATIONS, LAWS, ORDINANCES & LICENSES**

The awarded vendor shall observe and obey all laws, ordinances, rules, and regulations, of the federal, state, and local government, which may be applicable to the supply of this product or service.

- a. Occupational License – Vendor shall submit within 10 calendar days after request.
- b. Specialty License(s) – Vendor shall possess at the time of the opening of the quote all necessary permits and/or license required for the sale of this product and/or service and upon the request of the County provide copies of licenses and/or permits within 10 calendar days after request.

5. **RECYCLED PRODUCTS**

It is the Lee County Board of County Commissioners' stated policy objective to "Ensure all departments are aware of the availability of recycled products..." (Administrative Code #AC-10-4). In an effort to provide the utmost opportunity for the use of recycled products by Lee County, vendors should list on their letterhead, all necessary information regarding any applicable recycled products they have available. Recycled products should meet all other specifications listed and have a minimum of 50%-recycled content. Whenever fiscally feasible, available recycled products will be purchased.

6. **WARRANTY/GUARANTY** (unless otherwise specified)

All materials and/or services furnished under this quote shall be warranted by the vendor to be free from defects and fit for the intended use.

7. **PRE-BID CONFERENCE**

A pre-bid conference will be held at the location, date, and time specified on the cover of this solicitation. Pre-bid conferences are generally non-mandatory, but it is highly recommended that everyone planning to submit a quote attend.

In the event a pre-bid conference is classified as mandatory, it will be so specified on the cover of this solicitation and it will be the responsibility of the quoter to ensure that they are represented at the pre-bid. Only those quoters who attend the pre-bid conference will be allowed to quote on this project.

8. **BIDDERS LIST MAINTENANCE**

A bidder should respond to "Request for Quotations" in order to be kept on the Bidder's List. Failure to respond to three different "request for quotations" may result in the vendor being removed from the Bidder's List. A bidder may do one of the following, in order to respond properly to the request:

- a. Submission of a quotation prior to the quote receipt deadline.
- b. Submission of a "no bid" notice prior to the quote receipt deadline.

9. **LEE COUNTY PAYMENT PROCEDURES**

All vendors are requested to mail one original invoice and one invoice copy to:

Lee County Finance Department  
Post Office Box 2238  
Fort Myers, FL 33902-2238

All invoices will be paid as directed by the Lee County payment procedure unless otherwise differently stated in the detailed specification portion of this quote.

Lee county will not be liable for request of payment deriving from aid, assistance, or help by any individual, vendor, quoter, or bidder for the preparation of these specifications.

Lee County is generally a tax-exempt entity subject to the provisions of the 1987 legislation regarding sales tax on services. Lee County will pay those taxes for which it is obligated, or it will provide a Certificate of Exemption furnished by the Department of Revenue. All contractors or quoters should include in their quote all sales or use taxes, which they will pay when making purchases of material or subcontractor's services.

10. **LEE COUNTY BID PROTEST PROCEDURE**

Any contractor/vendor/firm that has submitted a formal bid/quote/proposal to Lee County, and who is adversely affected by an intended decision with respect to the award of the formal bid/quote/proposal, shall file with the County's Purchasing Director or Public Works Director a written "Notice of Intent to File a Protest" not later than seventy-two (72) hours (excluding Saturdays, Sundays and Legal Holidays) after receipt of a "Notice of Intended Decision" from the County with respect to the proposed award of the formal bid/quote/proposal.

The "Notice of Intent to File a Protest" is one of two documents necessary to perfect Protest. The second document is the "Formal Written Protest", both documents are described below.

The "Notice of Intent to File a Protest" document shall state all grounds claimed for the Protest, and clearly indicate it as the "Notice of Intent to File a Protest". Failure to clearly indicate the Intent to file the Protest shall constitute a waiver of all rights to seek any further remedies provided for under this Protest Procedure.

The "Notice of Intent to File a Protest" shall be received ("stamped in") by the Purchasing Director or Public Works Director not later than Four o'clock (4:00) PM on the third working day following the day of receipt of the County's Notice of Intended Decision.

The affected party shall then file its Formal Written Protest within ten (10) calendar days after the time for the filing of the Notice of Intent to File a Protest has expired. Except as provided for in the paragraph below, upon filing of the Formal Written Protest, the contractor/vendor/firm shall post a bond, payable to the Lee County Board of County Commissioners in an amount equal to five percent (5%) of the total bid/quote/proposal, or Ten Thousand Dollars (\$10,000.00), whichever is less. Said bond shall be designated and held for payment of any costs that may be levied against the protesting contractor/vendor/firm by the Board of County Commissioners, as the result of a frivolous Protest.

A clean, Irrevocable Letter of Credit or other form of approved security, payable to the County, may be accepted. Failure to submit a bond, letter of credit, or other approved security simultaneously with the Formal Written Protest shall invalidate the protest, at which time the County may continue its procurement process as if the original "Notice of Intent to File a Protest" had never been filed.

Any contractor/vendor/firm submitting the County's standard bond form (CSD: 514), along with the bid/quote/proposal, shall not be required to submit an additional bond with the filing of the Formal Written Protest.

The Formal Written Protest shall contain the following:



- County bid/quote/proposal identification number and title.
- Name and address of the affected party, and the title or position of the person submitting the Protest.
- A statement of disputed issues of material fact. If there are no disputed material facts, the Formal Protest must so indicate.
- A concise statement of the facts alleged, and of the rules, regulations, statues, or constitutional provisions, which entitle the affected party to relief.
- All information, documents, other materials, calculations, and any statutory or case law authority in support of the grounds for the Protest.
- A statement indicating the relief sought by the affected (protesting) party.
- Any other relevant information that the affected party deems to be material to Protest.

Upon receipt of a timely filed "Notice of Intent to File a Protest", the Purchasing Director or Public Works Director (as appropriate) may abate the award of the formal bid/quote/proposal as appropriate, until the Protest is heard pursuant to the informal hearing process as further outlined below, except and unless the County Manager shall find and set forth in writing, particular facts and circumstances that would require an immediate award of the formal bid/quote/proposal for the purpose of avoiding a danger to the public health, safety, or welfare. Upon such written finding by the County Manager, the County Manager may authorize an expedited Protest hearing procedure. The expedited Protest hearing shall be held within ninety-six (96) hours of the action giving rise to the contractor/vendor/firm's Protest, or as soon as may be practicable for all parties. The "Notice of Intent to File a Protest" shall serve as the grounds for the affected party's presentation and the requirements for the submittal of a formal, written Protest under these procedures, to include the requirement for a bond, shall not apply.

The Dispute Committee shall conduct an informal hearing with the protesting contractor/vendor/firm to attempt to resolve the Protest, within seven working days (excluding Saturdays, Sundays and legal holidays) from receipt of the Formal Written Protest. The Chairman of the Dispute Committee shall ensure that all affected parties may make presentations and rebuttals, subject to reasonable time limitations, as appropriate. The purpose of the informal hearing by the Dispute Committee, the protestor and other affected parties is to provide and opportunity: (1) to review the basis of the Protest; (2) to evaluate the facts and merits of the Protest; and (3) to make a determination whether to accept or reject the Protest.

Once a determination is made by the Dispute Committee with respect to the merits of the Protest, the Dispute Committee shall forward to the Board of County Commissioners its recommendations, which shall include relevant background information related to the procurement.

Upon receiving the recommendation from the Dispute Committee, the Board of County Commissioners shall conduct a hearing on the matter at a regularly scheduled meeting. Following presentations by the affected parties, the Board shall render its decision on the merits of the Protest.

If the Board's decision upholds the recommendation by the Dispute Committee regarding the award, and further finds that the Protest was either frivolous and/or lacked merit, the Board, at its discretion, may assess costs, charges, or damages associated with any delay of the award, or any costs incurred with regard to the protest. These costs, charges or damages may be deducted from the security (bond or letter of credit) provided by the contractor/vendor/firm. Any costs, charges or damages assessed by the Board in excess of the security shall be paid by the protesting contractor/vendor/firm within thirty (30) calendar days of the Board's final determination concerning the award.

All formal bid/quote/proposal solicitations shall set forth the following statement:

**“FAILURE TO FOLLOW THE BID PROTEST PROCEDURE REQUIREMENTS WITHIN THE TIMEFRAMES AS PRESCRIBED HEREIN AND ESTABLISHED BY LEE COUNTY BOARD OF COUNTY COMMISSIONERS, FLORIDA, SHALL CONSTITUTE A WAIVER OF YOUR PROTEST AND ANY RESULTING CLAIMS.”**

11. **PUBLIC ENTITY CRIME**

Any person or affiliate as defined by statute who has been placed on the convicted vendor list following a conviction for a public entity crime may not submit a bid or a contract to provide any goods or services to the County; may not submit a bid on a contract with the County for the construction or repair of a public building or a public work; may not submit bids or leases of real property to the County; may not be awarded or perform works as a contractor, supplier, subcontractor, or consultant under a contract with the County, and may not transact business with the County in excess of \$25,000.00 for a period of 36 months from the date of being placed on the convicted vendor list.

12. **QUALIFICATION OF QUOTERS** (unless otherwise noted)

Quotes will be considered only from firms normally engaged in the sale and distribution or provision of the services as specified herein. Quoters shall have adequate organization, facilities, equipment, and personnel to ensure prompt and efficient service to Lee County. The County reserves the right before recommending any award to inspect the facilities and organization; or to take any other action necessary to determine ability to perform is satisfactory, and reserves the right to reject quotes where evidence submitted or investigation and evaluation indicates an inability of the quoter to perform.

13. **MATERIAL SAFETY DATA SHEETS**

In accordance with Chapter 443 of the Florida Statutes, it is the vendor's responsibility to provide Lee County with Materials Safety Data Sheets on quoted materials, as may apply to this procurement.

14. **MISCELLANEOUS**

If a conflict exists between the General Conditions and the detailed specifications, then the detailed specifications shall prevail.

15. **WAIVER OF CLAIMS**

Once this contract expires, or final payment has been requested and made, the awarded contractor shall have no more than 30 days to present or file any claims against the County concerning this contract. After that period, the County will consider the Contractor to have waived any right to claims against the County concerning this agreement.

16. **AUTHORITY TO PIGGYBACK**

It is hereby made a precondition of any quote and a part of these specifications that the submission of any quote in response to this request constitutes a quote made under the same conditions, for the same price, and for the same effective period as this quote, to any other governmental entity.

17. **COUNTY RESERVES THE RIGHT**

a) **State Contract**

If applicable, the County reserves the right to purchase any of the items in this quote from State Contract Vendors if the prices are deemed lower on State Contract than the prices we receive in this quotation.

b) **Any Single Large Project**

The County, in its sole discretion, reserves the right to separately quote any project that is outside the scope of this quote, whether through size, complexity, or dollar value.

c) **Disadvantaged Business Enterprises**

The County, in its sole discretion, reserves the right to purchase any of the items in this quote from Disadvantage Business Enterprise vendor if the prices are determined to be in the best interest of the County, to assist the County in the fulfillment of any of the County's grant commitments to federal or state agencies.

The County further reserves the right to purchase any of the items in this quote from DBE's to fulfill the County's state policy toward DBE's as outlined in County Ordinance 88-45 and 90-04, as amended.

d) **Anti-Discrimination**

The vendor for itself, its successors in interest, and assignees, as part of the consideration there of covenant and agree that:

In the furnishing of services to the County hereunder, no person on the grounds of race, religion, color, age, sex, national origin, handicap or marital status shall be excluded from participation in, denied the benefits of, or otherwise be subjected to discrimination.

The vendor will not discriminate against any employee or applicant for employment because of race, religion, color, age, sex, national origin, handicap or marital status. The vendor will make affirmative efforts to insure that applicants are employed and that employees are treated during employment without regard to their race, religion, color, age, sex, national origin, handicap or marital status. Such action shall include, but not be limited to, acts of employment, upgrading, demotion or transfer; recruitment advertising; layoff or termination, rates of pay or other forms of compensation and selection for training, including apprenticeship.

Vendor agrees to post in a conspicuous place, available to employees and applicants for employment, notices setting forth the provisions of this anti-discrimination clause.

Vendor will provide all information and reports required by relevant regulations and/or applicable directives. In addition, the vendor shall permit access to its books, records, accounts, other sources of information, and its facilities as may be determined by the County to be pertinent to ascertain compliance. The vendor shall maintain and make available relevant data showing the extent to which members of minority groups are beneficiaries under these contracts.

Where any information required of the vendor is in the exclusive possession of another who fails or refuses to furnish this information, the vendor shall so certify to the County its effort made toward obtaining said information. The vendor shall remain obligated under this paragraph until the expiration of three (3) years after the termination of this contract.

In the event of breach of any of the above anti-discrimination covenants, the County shall have the right to impose sanctions as it may determine to be appropriate, including withholding payment to the vendor or canceling, terminating, or suspending this contract, in whole or in part.

Additionally, the vendor may be declared ineligible for further County contracts by rule, regulation or order of the Board of County Commissioners of Lee County, or as otherwise provided by law.

The vendor will send to each union, or representative of workers with which the vendor has a collective bargaining agreement or other contract of understanding, a notice informing the labor union of worker's representative of the vendor's commitments under this assurance, and shall post copies of the notice in conspicuous places available to the employees and the applicants for employment.

The vendor will include the provisions of this section in every subcontract under this contract to insure its provisions will be binding upon each subcontractor. The vendor will take such actions with respect to any subcontractor, as the contracting agency may direct, as a means of enforcing such provisions, including sanctions for non-compliance.

18. **AUDITABLE RECORDS**

The awarded vendor shall maintain auditable records concerning the procurement adequate to account for all receipts and expenditures, and to document compliance with the specifications. These records shall be kept in accordance

with generally accepted accounting methods, and Lee County reserves the right to determine the record-keeping method required in the event of non-conformity. These records shall be maintained for two years after completion of the project and shall be readily available to County personnel with reasonable notice, and to other persons in accordance with the Florida Public Disclosure Statues.

19. **DRUG FREE WORKPLACE**

Whenever two or more quotes/proposals, which are equal with respect to price, quality and service, are received for the procurement of commodities or contractual services, a quote/proposal received from a business that certifies that it has implemented a drug-free workplace program shall be given preference in the award process. In order to have a drug-free workplace program, a business shall comply with the requirements of Florida Statutes 287.087.

20. **REQUIRED SUBMITTALS**

Any submittals requested should be returned with the quote response. This information may be accepted after opening, but no later than 10 calendar days after request.

21. **TERMINATION**

Any agreement as a result of this quote may be terminated by either party giving thirty (30) calendar days advance written notice. The County reserves the right to accept or not accept a termination notice submitted by the vendor, and no such termination notice submitted by the vendor shall become effective unless and until the vendor is notified in writing by the County of its acceptance.

The Purchasing Director may immediately terminate any agreement as a result of this quote for emergency purposes, as defined by the Lee County Purchasing and Payment Procedure Manual.

Any vendor who has voluntarily withdrawn from a formal quote/proposal without the County's mutual consent during the contract period shall be barred from further County procurement for a period of 180 days. The vendor may apply to the Board of Lee County Commissioners for waiver of this debarment. Such application for waiver of debarment must be coordinated with and processed by Purchasing.

22. **CONFIDENTIALITY**

Vendors should be aware that all submittals (including financial statements) provided with a quote/proposal are subject to public disclosure and will **not** be afforded confidentiality.

23. **ANTI-LOBBYING CLAUSE**

All firms are hereby placed on formal notice that neither the County Commissioners nor candidates for County Commission, nor any employees from the Lee County Government, Lee County staff members, nor any members of the Qualification/Evaluation Review Committee are to be lobbied, either individually or collectively, concerning this project. Firms and their agents who intend to submit qualifications, or have submitted qualifications, for this project are hereby placed on *formal notice* that they are *not* to contact County personnel for such purposes as holding meetings of introduction, meals, or meetings relating to the selection process outside of those specifically scheduled by the County for negotiations. Any such lobbying activities may cause immediate disqualification for this project.

24. **INSURANCE (AS APPLICABLE)**

Insurance shall be provided, per the attached insurance guide. Upon request, an insurance certificate complying with the attached guide may be required prior to award.

**LEE COUNTY, FLORIDA  
PROPOSAL QUOTE FORM  
FOR THE ANNUAL PURCHASE OF GENERATORS  
(GENERATOR FOR FLEET)**

DATE SUBMITTED: \_\_\_\_\_

VENDOR NAME: \_\_\_\_\_

TO: The Board of County Commissioners  
Lee County  
Fort Myers, Florida

Having carefully examined the "General Conditions", and the "Detailed Specifications", all of which are contained herein, the Undersigned proposes to furnish the following which meet these specifications:

The undersigned acknowledges receipt of Addenda numbers:

\_\_\_\_\_

**GRAND TOTAL COST OF THE GENERATOR AS SPECIFIED:**

\$ \_\_\_\_\_

PLEASE SPECIFY THE ENGINE MANUFACTURER FOR THE GENERATOR YOU ARE QUOTING:

\_\_\_\_\_

NOTE: ANY NON-MATCHING ENGINE BRAND(S) ARE SUBJECT TO PRE-APPROVAL BY LEE COUNTY.

OPTION A: 5 YEAR COMPREHENSIVE EXTENDED WARRANTY PACKAGE

ADDITIONAL COST OF OPTION A: \$ \_\_\_\_\_



WILL YOU DELIVER WITH YOUR OWN VEHICLE AS OPPOSED TO COMMON CARRIER?

YES \_\_\_\_\_ NO \_\_\_\_\_

TO BE DELIVERED WITHIN \_\_\_\_\_ CALENDAR DAYS AFTER RECEIPT OF AWARD AND PURCHASE ORDER.

Does your firm have a location/office/facility in Lee County?

YES \_\_\_\_\_ NO \_\_\_\_\_

Address: \_\_\_\_\_

Quoters should carefully read all the terms and conditions of the specifications. Any representation of deviation or modification to the quote may be grounds to reject the quote.

Are there any modifications to the quote or specifications:

Yes \_\_\_\_\_ No \_\_\_\_\_

Failure to clearly identify any modifications in the space below or on a separate page may be grounds for the quoter being declared nonresponsive or to have the award of the quote rescinded by the County.

MODIFICATIONS:

Quoter shall submit his/her quote on the County's Proposal Quote Form, including the firm name and authorized signature. Any blank spaces on the Proposal Quote Form, qualifying notes or exceptions, counter offers, lack of required submittals, or signatures, on County's Form may result in the Quoter/Quote being declared non-responsive by the County.

ANTI-COLLUSION STATEMENT

**THE BELOW SIGNED QUOTER HAS NOT DIVULGED TO, DISCUSSED OR COMPARED HIS QUOTE WITH OTHER QUOTERS AND HAS NOT COLLUDED WITH ANY OTHER QUOTER OR PARTIES TO A QUOTE WHATSOEVER. NOTE: NO PREMIUMS, REBATES OR GRATUITIES TO ANY EMPLOYEE OR AGENT ARE PERMITTED EITHER WITH, PRIOR TO, OR AFTER ANY DELIVERY OF MATERIALS. ANY SUCH VIOLATION WILL RESULT IN THE CANCELLATION AND/OR RETURN OF MATERIAL (AS APPLICABLE) AND THE REMOVAL FROM THE MASTER BIDDERS LIST.**

FIRM NAME \_\_\_\_\_

BY (Printed): \_\_\_\_\_

BY (Signature): \_\_\_\_\_

TITLE: \_\_\_\_\_

FEDERAL ID # OR S.S.# \_\_\_\_\_

ADDRESS: \_\_\_\_\_

\_\_\_\_\_

PHONE NO.: \_\_\_\_\_

FAX NO.: \_\_\_\_\_

CELLULAR PHONE/PAGER NO.: \_\_\_\_\_

LEE COUNTY OCCUPATIONAL LICENSE NUMBER: \_\_\_\_\_

E-MAIL ADDRESS: \_\_\_\_\_

REVISED: 7/28/00

**LEE COUNTY, FLORIDA  
DETAILED SPECIFICATIONS FOR  
THE ANNUAL PURCHASE OF GENERATORS  
(GENERATOR FOR FLEET)**

SCOPE

The intent of this specification is to provide for the purchase of a generator that will be located at: Lee County Fleet Management, 2955 Van Buren Street, Fort Myers, FL 33916.

This purchase is made in accordance with the terms and conditions of Lee County Formal Quote No.: Q-040331 – incorporating the revisions made via Addendum #1 – dated April 14, 2004 – which was opened by Lee County Purchasing on April 27, 2004; and awarded by the Lee County Board of County Commissioners on June 29, 2004. (Vendors – please refer to this document.) As per this award, only the following vendors are eligible to submit a quotation:

\*Cummins Southeastern Power

\*Pantropic Power

\*Florida Detroit Diesel – Allison.

PRE-BID CONFERENCE

A pre-bid conference will be held at the date/time/location stated on the cover page of this solicitation. Attendance is mandatory; as this will be the only opportunity offered to see the site where the generator will be located and to ask questions related to the project.

GENERATOR SPECIFICATIONS

The following are the minimum specifications for this generator purchase:

General Requirements Description:

- 480 volt
- 3 Phase, 4 wire
- 1800 RPM .8 power factor
- 60 Cycle
- 350 Kilowatt power output

Enclosure:

- Aluminum cabinet, weather proof
- Enclosure type: skin-tight
- Non-corrosive fasteners
- Rated to survive 150 MPH wind speed
- Fixed louvers
- Exterior work lights
- Battery Charger, Float type

- Roof-mounted critical muffler
- Flex connection, engine to muffler
- Locking service door
- Stationary - Mounted on a solid, reinforced concrete pad, 18 foot by 8 foot outside of building. Note: Lee County will furnish this pad.

Generator Set:

- Diesel powered
- Radiator cooled, rated 110 ambient
- Block Heaters
- Blower Fan
- Voltage regulated 1%
- Isochronous Speed regulated
- Remote emergency stop
- Voltage sensing 3 phase
- Remote enunciator panel
- 2-4/D batteries in parallel
- 1000 gallon main fuel tank – above ground. This tank shall be a UL 142 double wall steel tank meeting all applicable Florida EPA guidelines and include the Florida Spill Package. A set of steps with handrail (meeting OSHA and EPA approvals as applicable) made of anodized aluminum shall be provided which lead to the tank surface. The tank will be used as the catwalk. Tank height must be less than 30” from grade. NOTE: A drawing should be submitted with your quote package showing where the steps will be located.

Transfer Switch:

- 1600 amp
- 3-pole
- Microprocessor
- Normal source sensing 70 to 100% adjustable
- Three (3) phase sensing
- LED circuit function indicators
- Test switch to simulate power failure
- Seven (7) day exerciser
- Normal and emergency indicator lamps
- Engine start contacts
- Time delay to start adjustable 1 to 60 seconds
- Time delay normal to emergency adjustable 1 to 60 seconds
- Time delay emergency to normal adjustable 5 minutes to 30 minutes
- Time delay to transfer emergency to normal adjustable 1 to 60 seconds
- NEMA 6 enclosure – stainless steel with locking door. This enclosure must be watertight as the switch will be located on the outside of the building.

BASIS OF AWARD

The basis of award will be the low quoter (grand total) meeting specifications.

OPTION A – 5 YEAR COMPREHENSIVE EXTENDED WARRANTY PACKAGE

In the space provided on the Proposal Quote Form, please provide the cost of a 5 year comprehensive extended warranty package.

Please include with your quote package literature detailing what this warranty includes and what is covered.

LEE COUNTY PURCHASING - BIDDERS CHECK LIST

**IMPORTANT:** Please read carefully and return with your bid proposal.

Please check off each of the following items as the necessary action is completed:

- 1. The Quote has been signed.
- 2. The Quote prices offered have been reviewed.
- 3. The price extensions and totals have been checked.
- 4. The original (must be manually signed) and 2 copies of the quote have been submitted.
- 5. Three (3) identical sets of descriptive literature, brochures and/or data (if required) have been submitted under separate cover.
- 6. All modifications have been acknowledged in the space provided.
- 7. All addendums issued, if any, have been acknowledged in the space provided.
- 8. Erasures or other changes made to the quote document have been initialed by the person signing the quote.
- 9. Bid Bond and/or certified Check, (if required) have been submitted with the quote in amounts indicated.
- 10. Any Delivery information required is included.

- 11. The mailing envelope has been addressed to:
 

<b>MAILING ADDRESS</b>	<b>PHYSICAL ADDRESS</b>
Lee County Purchasing	Lee County Purchasing
P.O. Box 398                      or	1825 Hendry St 3 <sup>rd</sup> Floor
Ft. Myers, FL 33902-0398	Ft. Myers, FL 33901

- 12. The mailing envelope **MUST** be sealed and marked with:  
Quote Number  
Opening Date and/or Receiving Date

- 13. The quote will be mailed or delivered in time to be received no later than the specified opening date and time. (Otherwise quote cannot be considered or accepted.)

- 14. If submitting a "NO BID" please write quote number here \_\_\_\_\_ and check one of the following:  
 Do not offer this product       Insufficient time to respond.  
 Unable to meet specifications (why)  
 Unable to meet bond or insurance requirement.  
 Other: \_\_\_\_\_

Company Name and Address:  
 \_\_\_\_\_  
 \_\_\_\_\_



**LEE COUNTY**  
SOUTHWEST FLORIDA

**BOARD OF COUNTY COMMISSIONERS**  
July 26, 2004

Writer's Direct Dial Number: \_\_\_\_\_

Bob Janes  
District One

Douglas R. Smith  
District Two  
**Quotation No.: Q-040331**

Ray Judah  
District Three

Andrew W. Coy  
District Four

John E. Albion  
District Five

Donald D. Stilwell  
County Manager

James G. Yaelo  
County Attorney

Diana M. Parker  
County Hearing  
Examiner

**LEE COUNTY ADDENDUM NUMBER ONE  
TO THE SPECIFICATIONS FOR  
ANNUAL PURCHASE OF GENERATORS  
(GENERATOR FLEET)**

**QUOTERS MUST ACKNOWLEDGE RECEIPT OF THIS ADDENDUM ON THE PROPOSAL QUOTE FORM (PAGE 13).**

**The original specifications and other contract documents are amended as noted below:**

**Please replace page 17 with page 17A to which the following additions/changes/revisions have been made:**

- \*Pad will be 4 inches off grade
- \*2-8/D batteries in series (24 volt dc)
- \*1-600 amp circuit breaker (thermal magnetic)
- \* Voltage sensing 3 phase (pmg)
- \* NEMA 4X enclosure – stainless steel with locking door. This enclosure must be watertight as the switch will be located on the outside of the building.

If there are any questions regarding this addendum, please contact Bob Franceschini at 239-344-5450.

DIVISION OF PURCHASING

Robert D. Franceschini, C.P.M., CPPB  
Purchasing Agent

cc: Bill Prussman/Fleet  
Baxter Rothell/Facilities  
Lisa Pierce/Minutes

- Roof-mounted critical muffler
- Flex connection, engine to muffler
- Locking service door
- Stationary - Mounted on a solid, reinforced concrete pad, 18 foot by 8 foot outside of building.  
Note: Lee County will furnish this pad. Pad will be 4 inches off grade.

Generator Set:

- Diesel powered
- Radiator cooled, rated 110 ambient
- Block Heaters
- Blower Fan
- Voltage regulated 1%
- Isochronous Speed regulated
- Remote emergency stop
- Voltage sensing 3 phase (pmg)
- Remote enunciator panel
- 2-8/D batteries in series (24 volt dc)
- 1-600 amp circuit breaker (thermal magnetic)
- 1000 gallon main fuel tank – above ground. This tank shall be a UL 142 double wall steel tank meeting all applicable Florida EPA guidelines and include the Florida Spill Package. A set of steps with handrail (meeting OSHA and EPA approvals as applicable) made of anodized aluminum shall be provided which lead to the tank surface. The tank will be used as the catwalk. Tank height must be less than 30" from grade. NOTE: A drawing should be submitted with your quote package showing where the steps will be located.

Transfer Switch:

- 1600 amp
- 3-pole
- Microprocessor
- Normal source sensing 70 to 100% adjustable
- Three (3) phase sensing
- LED circuit function indicators
- Test switch to simulate power failure
- Seven (7) day exerciser
- Normal and emergency indicator lamps
- Engine start contacts
- Time delay to start adjustable 1 to 60 seconds
- Time delay normal to emergency adjustable 1 to 60 seconds
- Time delay emergency to normal adjustable 5 minutes to 30 minutes
- Time delay to transfer emergency to normal adjustable 1 to 60 seconds
- NEMA 4X enclosure – stainless steel with locking door. This enclosure must be watertight as the switch will be located on the outside of the building.



LEE COUNTY, FLORIDA  
PROPOSAL QUOTE FORM  
FOR THE ANNUAL PURCHASE OF GENERATORS  
(GENERATOR FOR FLEET)

DATE SUBMITTED: 8/03/04

VENDOR NAME: Cummins Southeastern Power

TO: The Board of County Commissioners  
Lee County  
Fort Myers, Florida

Having carefully examined the "General Conditions", and the "Detailed Specifications", all of which are contained herein, the Undersigned proposes to furnish the following which meet these specifications:

The undersigned acknowledges receipt of Addenda numbers:  
Addenda 1 *gdp*

**GRAND TOTAL COST OF THE GENERATOR AS SPECIFIED:**

\$ 71,494,

PLEASE SPECIFY THE ENGINE MANUFACTURER FOR THE GENERATOR YOU ARE QUOTING:

Cummins

NOTE: ANY NON-MATCHING ENGINE BRAND(S) ARE SUBJECT TO PRE-APPROVAL BY LEE COUNTY.

OPTION A: 5 YEAR COMPREHENSIVE EXTENDED WARRANTY PACKAGE

ADDITIONAL COST OF OPTION A: \$ 1540.00

WILL YOU DELIVER WITH YOUR OWN VEHICLE AS OPPOSED TO COMMON CARRIER?

YES   X   NO                     

TO BE DELIVERED WITHIN  70  CALENDAR DAYS AFTER RECEIPT OF AWARD AND PURCHASE ORDER.

Does your firm have a location/office/facility in Lee County?

YES   X   NO                     

Address: 2671 Edison Ave. Ft. Myers, FL 33916

Quoters should carefully read all the terms and conditions of the specifications. Any representation of deviation or modification to the quote may be grounds to reject the quote.

Are there any modifications to the quote or specifications:

Yes                      No   X  

Failure to clearly identify any modifications in the space below or on a separate page may be grounds for the quoter being declared nonresponsive or to have the award of the quote rescinded by the County.

MODIFICATIONS:

Quoter shall submit his/her quote on the County's Proposal Quote Form, including the firm name and authorized signature. Any blank spaces on the Proposal Quote Form, qualifying notes or exceptions, counter offers, lack of required submittals, or signatures, on County's Form may result in the Quoter/Quote being declared non-responsive by the County.

ANTI-COLLUSION STATEMENT

THE BELOW SIGNED QUOTER HAS NOT DIVULGED TO, DISCUSSED OR COMPARED HIS QUOTE WITH OTHER QUOTERS AND HAS NOT COLLUDED WITH ANY OTHER QUOTER OR PARTIES TO A QUOTE WHATSOEVER. NOTE: NO PREMIUMS, REBATES OR GRATUITIES TO ANY EMPLOYEE OR AGENT ARE PERMITTED EITHER WITH, PRIOR TO, OR AFTER ANY DELIVERY OF MATERIALS. ANY SUCH VIOLATION WILL RESULT IN THE CANCELLATION AND/OR RETURN OF MATERIAL (AS APPLICABLE) AND THE REMOVAL FROM THE MASTER BIDDERS LIST.

FIRM NAME C.S.P.I., Inc.

BY (Printed): Jeff DeMars

BY (Signature): 

TITLE: Sales Manager

FEDERAL ID # OR S.S.# 59-2029422

ADDRESS: 2671 Edison Ave.

Ft. Myers, FL 33916

PHONE NO.: 239-337-1211

FAX NO.: 239-337-7851

CELLULAR PHONE/PAGER NO.: 239-229-4417

LEE COUNTY OCCUPATIONAL LICENSE NUMBER: 893566

E-MAIL ADDRESS: jeffery.a.demars@cummins.com

REVISED: 7/28/00

**LEE COUNTY, FLORIDA  
DETAILED SPECIFICATIONS FOR  
THE ANNUAL PURCHASE OF GENERATORS  
(GENERATOR FOR FLEET)**

SCOPE

The intent of this specification is to provide for the purchase of a generator that will be located at: Lee County Fleet Management, 2955 Van Buren Street, Fort Myers, FL 33916.

This purchase is made in accordance with the terms and conditions of Lee County Formal Quote No.: Q-040331 – incorporating the revisions made via Addendum #1 – dated April 14, 2004 – which was opened by Lee County Purchasing on April 27, 2004; and awarded by the Lee County Board of County Commissioners on June 29, 2004. (Vendors – please refer to this document.) As per this award, only the following vendors are eligible to submit a quotation:

\*Cummins Southeastern Power

\*Pantropic Power

\*Florida Detroit Diesel – Allison.

PRE-BID CONFERENCE

A pre-bid conference will be held at the date/time/location stated on the cover page of this solicitation. Attendance is mandatory; as this will be the only opportunity offered to see the site where the generator will be located and to ask questions related to the project.

GENERATOR SPECIFICATIONS

The following are the minimum specifications for this generator purchase:

General Requirements Description:

- 480 volt
- 3 Phase, 4 wire
- 1800 RPM .8 power factor
- 60 Cycle
- 350 Kilowatt power output

Enclosure:

- Aluminum cabinet, weather proof
- Enclosure type: skin-tight
- Non-corrosive fasteners
- Rated to survive 150 MPH wind speed
- Fixed louvers
- Exterior work lights
- Battery Charger, Float type

- Roof-mounted critical muffler
- Flex connection, engine to muffler
- Locking service door
- Stationary - Mounted on a solid, reinforced concrete pad, 18 foot by 8 foot outside of building. Note: Lee County will furnish this pad.

Generator Set:

*4" pad at grade*

- Diesel powered
- Radiator cooled, rated 110 ambient
- Block Heaters
- Blower Fan
- Voltage regulated 1%
- Isochronous Speed regulated
- Remote emergency stop
- Voltage sensing 3 phase *(pmb)*
- Remote enunciator panel
- 2-4/D batteries in parallel
- 1000 gallon main fuel tank – above ground. This tank shall be a UL 142 double wall steel tank meeting all applicable Florida EPA guidelines and include the Florida Spill Package. A set of steps with handrail (meeting OSHA and EPA approvals as applicable) made of anodized aluminum shall be provided which lead to the tank surface. The tank will be used as the catwalk. Tank height must be less than 30" from grade. NOTE: A drawing should be submitted with your quote package showing where the steps will be located.

*1000 Amp breaker*

Transfer Switch:

- 1600 amp
- 3-pole
- Microprocessor
- Normal source sensing 70 to 100% adjustable
- Three (3) phase sensing
- LED circuit function indicators
- Test switch to simulate power failure
- Seven (7) day exerciser
- Normal and emergency indicator lamps
- Engine start contacts
- Time delay to start adjustable 1 to 60 seconds
- Time delay normal to emergency adjustable 1 to 60 seconds
- Time delay emergency to normal adjustable 5 minutes to 30 minutes
- Time delay to transfer emergency to normal adjustable 1 to 60 seconds
- NEMA 6 enclosure – stainless steel with locking door. This enclosure must be watertight as the switch will be located on the outside of the building.

*NEMA 4X - stainless steel*

## Addendum One - Formal Quote Q-040331

- Roof-mounted critical muffler
  - Flex connection, engine to muffler
  - Locking service door
  - Stationary - Mounted on a solid, reinforced concrete pad, 18 foot by 8 foot outside of building.
- Note: Lee County will furnish this pad. Pad will be 4 inches off grade.

Generator Set:

- Diesel powered
- Radiator cooled, rated 110 ambient
- Block Heaters
- Blower Fan
- Voltage regulated 1%
- Isochronous Speed regulated
- Remote emergency stop
- Voltage sensing 3 phase (pmg)
- Remote enunciator panel
- 2-8/D batteries in series (24 volt dc)
- 1-600 amp circuit breaker (thermal magnetic)
- 1000 gallon main fuel tank – above ground. This tank shall be a UL 142 double wall steel tank meeting all applicable Florida EPA guidelines and include the Florida Spill Package. A set of steps with handrail (meeting OSHA and EPA approvals as applicable) made of anodized aluminum shall be provided which lead to the tank surface. The tank will be used as the catwalk. Tank height must be less than 30" from grade. NOTE: A drawing should be submitted with your quote package showing where the steps will be located.

Transfer Switch:

- 1600 amp
- 3-pole
- Microprocessor
- Normal source sensing 70 to 100% adjustable
- Three (3) phase sensing
- LED circuit function indicators
- Test switch to simulate power failure
- Seven (7) day exerciser
- Normal and emergency indicator lamps
- Engine start contacts
- Time delay to start adjustable 1 to 60 seconds
- Time delay normal to emergency adjustable 1 to 60 seconds
- Time delay emergency to normal adjustable 5 minutes to 30 minutes
- Time delay to transfer emergency to normal adjustable 1 to 60 seconds
- NEMA 4X enclosure – stainless steel with locking door. This enclosure must be watertight as the switch will be located on the outside of the building.

BASIS OF AWARD

The basis of award will be the low quoter (grand total) meeting specifications.

OPTION A – 5 YEAR COMPREHENSIVE EXTENDED WARRANTY PACKAGE

In the space provided on the Proposal Quote Form, please provide the cost of a 5 year comprehensive extended warranty package.

Please include with your quote package literature detailing what this warranty includes and what is covered.

LEE COUNTY PURCHASING - BIDDERS CHECK LIST

**IMPORTANT:** Please read carefully and return with your bid proposal.  
Please check off each of the following items as the necessary action is completed:

- 1. The Quote has been signed.
- 2. The Quote prices offered have been reviewed.
- 3. The price extensions and totals have been checked.
- 4. The original (must be manually signed) and 2 copies of the quote have been submitted.
- 5. Three (3) identical sets of descriptive literature, brochures and/or data (if required) have been submitted under separate cover.
- 6. All modifications have been acknowledged in the space provided.
- 7. All addendums issued, if any, have been acknowledged in the space provided.
- 8. Erasures or other changes made to the quote document have been initialed by the person signing the quote.
- 9. Bid Bond and/or certified Check, (if required) have been submitted with the quote in amounts indicated.
- 10. Any Delivery information required is included.
- 11. The mailing envelope has been addressed to:
 

<b>MAILING ADDRESS</b>	<b>PHYSICAL ADDRESS</b>
Lee County Purchasing	Lee County Purchasing
P.O. Box 398	1825 Hendry St 3 <sup>rd</sup> Floor
or	Ft. Myers, FL 33901
Ft. Myers, FL 33902-0398	
- 12. The mailing envelope **MUST** be sealed and marked with:  
Quote Number  
Opening Date and/or Receiving Date
- 13. The quote will be mailed or delivered in time to be received no later than the specified opening date and time. (Otherwise quote cannot be considered or accepted.)
- 14. If submitting a "NO BID" please write quote number here \_\_\_\_\_ and check one of the following:  
 Do not offer this product     Insufficient time to respond.  
 Unable to meet specifications (why)  
 Unable to meet bond or insurance requirement.  
 Other: \_\_\_\_\_

Company Name and Address:  
Cummins Southeastern Power, Inc.  
2671 Edison Ave. Ft. Myers, FL 33916





# LEE COUNTY

SOUTHWEST FLORIDA

BOARD OF COUNTY COMMISSIONERS  
July 26, 2004

Bob Janes  
District One

Douglas R. Smith  
District Two

Ray Judah  
District Three

Andrew W. Coy  
District Four

John E. Albion  
District Five

Donald D. Stilwell  
County Manager

James G. Yarbrough  
County Attorney

Diana M. Parker  
County Hearing  
Examiner

Post-it® Fax Note	7671	Date	7-27	# of pages	2
To	Jeff De Mars	From	P.H.		
Co./Dept.	Cummins SE	Co.	Lee Co. Purchasing		
Phone #		Phone #	239-344-5450		
Fax #	337-7851	Fax #			

## LEE COUNTY ADDENDUM NUMBER ONE TO THE SPECIFICATIONS FOR ANNUAL PURCHASE OF GENERATORS (GENERATOR FLEET)

**QUOTERS MUST ACKNOWLEDGE RECEIPT OF THIS ADDENDUM ON THE PROPOSAL QUOTE FORM (PAGE 13).**

The original specifications and other contract documents are amended as noted below:

**Please replace page 17 with page 17A to which the following additions/changes/revisions have been made:**

- \*Pad will be 4 inches off grade
- \*2-8/D batteries in series (24 volt dc)
- \*1-600 amp circuit breaker (thermal magnetic)
- \* Voltage sensing 3 phase (pmsg)
- \* NEMA 4X enclosure – stainless steel with locking door. This enclosure must be watertight as the switch will be located on the outside of the building.

If there are any questions regarding this addendum, please contact Bob Franceschini at 239-344-5450.

DIVISION OF PURCHASING

Robert D. Franceschini, C.P.M., CPPB  
Purchasing Agent

cc: Bill Prussman/Fleet  
Baxter Rothell/Facilities  
Lisa Pierce/Minutes

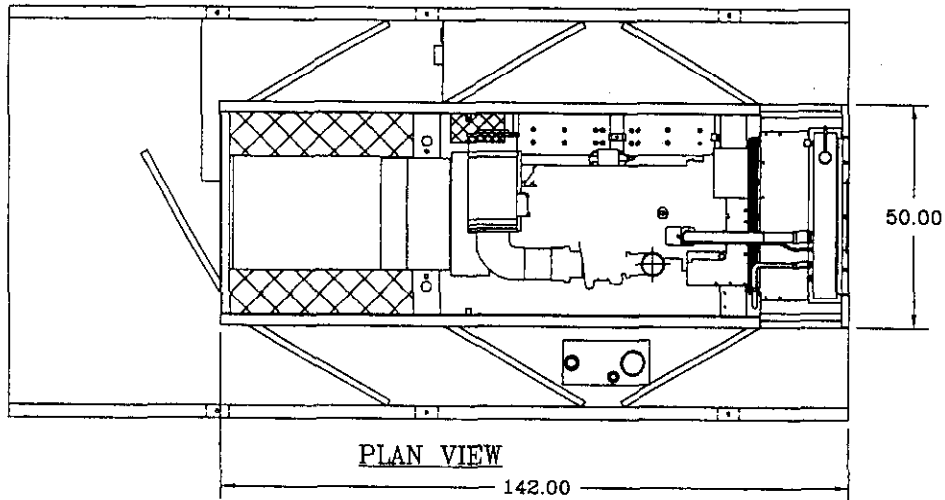

ENCLOSURE

- ON FRAME
- .090 ALUMINUM
- FIXED INTAKE LOUVERS
- EXPANDED EXHAUST OPENING
- MUFFLER BRACKETS & RAIN SHIELD
- TAILPIPE & RAIN CAP

FINISH

- TWO COATS PRIMER
- TWO COATS STANDARD ENAMEL
- COLOR CHOICE BY CUSTOMER

WEIGHT

- TANK - 3000 lbs
- FUEL - 7000 lbs
- GENERATOR - 7480 lbs
- ENCLOSURE - 900 lbs
- MUFFLER - 255 lbs

TOTAL - 9635 lbs

MUFFLER IS SHOWN FOR CLARITY AND MAY DIFFER

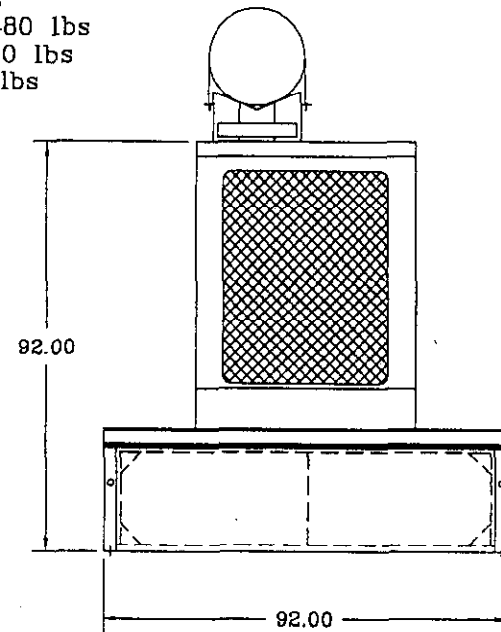
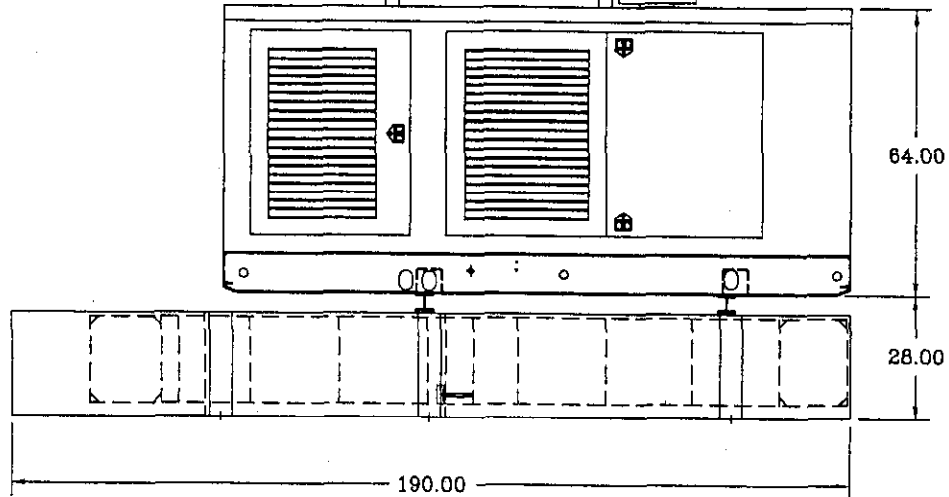
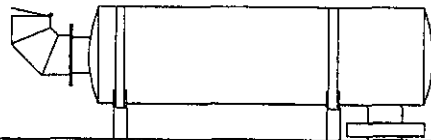

AUTHORIZATION:

GENERATOR MODEL NUMBER 350 DFCC SUBBASE CAPACITY 1000 GALLONS

UNIT DWG #: 500-3014 WEIGHT: SEE DWG

COLOR:

COMPANY: CUMMINS SE

ISOLATOR

JOB NAME: LEE COUNTY FLEET

PART NUMBER:

QUOTE NO.: 072804-E

COM-FAB, INC.

PLAIN CITY, OH

DATE: 7-30-04 DRAWN BY: TWM  
SCALE: NTS APPROVED BY: JFP

THIS PRINT IS THE PROPERTY OF COM-FAB, INC., AND MUST NOT BE USED IN ANY MANNER DETRIMENTAL TO THEIR INTEREST.

TITLE SUBBASE & ENCLOSURE

1		
2		
3		
4		
NO.	REVISION	DATE

DWG NO. 72804E SHEET: 2 OF: 2



CONDUIT ENTRY AREA  
PER 500-3014

- 5/8" MOUNTING HOLES
- INTERNAL TANK BAFFLING
- ALUMINUM OUTSIDE STEP WITH HANDRAIL
- HIGH FUEL SET @ 95%
- FEPA PACKAGE WITH ALARM PANEL

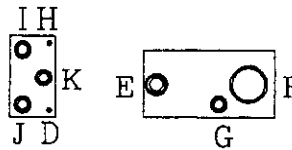

TANK FITTINGS

OPENING	SIZE NPT	DESCRIPTION
A	2"	RUPTURE DRAIN
B	3/4"	LEAK DET.
C	3/8"	DRAIN
D	3/4"	SUPPLY
E	2"	FILL
F	5"	EMERGENCY VENT
G	1 1/2"	GAUGE
H	3/4"	RETURN
I	1 1/2"	LOW FUEL
J	1 1/2"	HIGH FUEL
K	1 1/2"	VENT
L	20.25 IN <sup>2</sup>	VENT OPENING

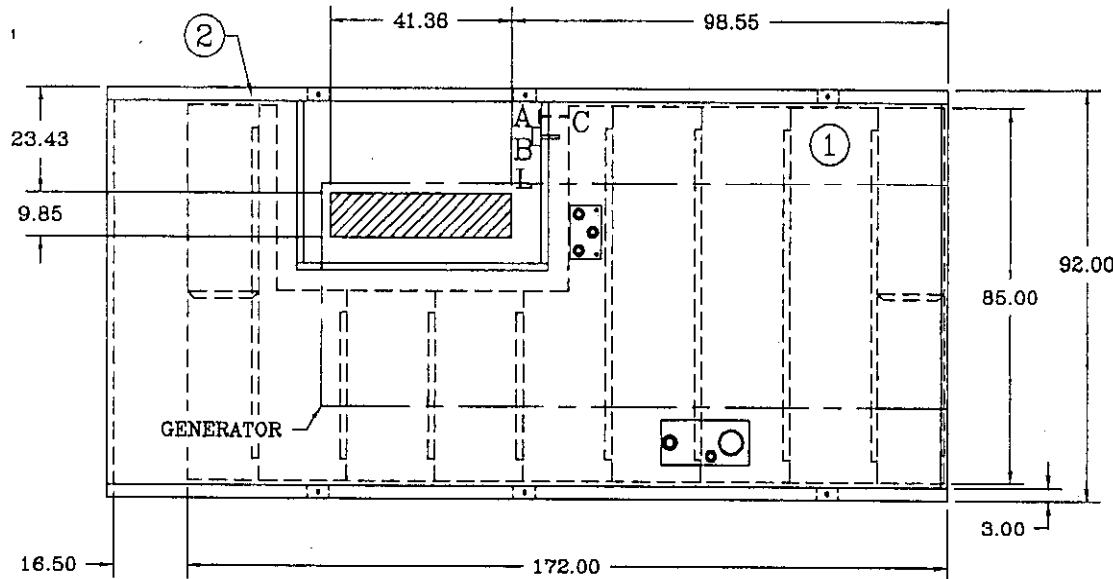

TOP VIEW

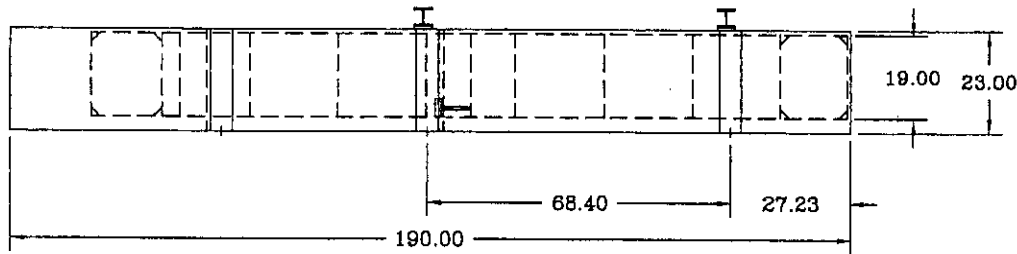

RIGHT SIDE VIEW

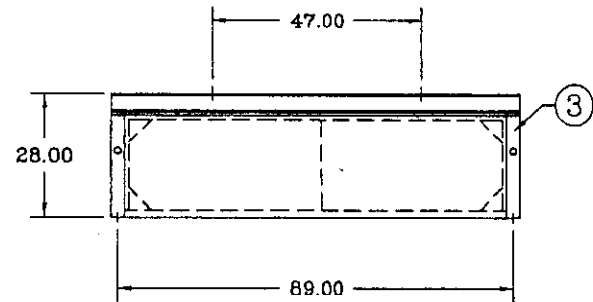

RADIATOR END VIEW



MATERIAL LIST

1	10 GA. TANK
2	10 GA. BASE
3	7 GA. SUPPORTS

UL LISTED

AUTHORIZATION:

GENERATOR MODEL NUMBER 350 DFCC

SUBBASE CAPACITY 1000 GALLONS

UNIT DWG #: 500-3014

WEIGHT: 3000 lbs

COM-FAB, INC.

PLAIN CITY, OH

COLOR:

COMPANY: CUMMINS SE

JOB NAME: LEE COUNTY FLEET

ISOLATOR

PART NUMBER:

QUOTE NO.: 072804-E

NO.	REVISION	DATE
1	ENCLOSURE	7/30
2		
3		
4		

DATE: 7-29-04

DRAWN BY: TWM

SCALE: NTS

APPROVED BY: JFP

THIS PRINT IS THE PROPERTY OF COM-FAB, INC., AND MUST NOT BE USED IN ANY MANNER DETERMINAL TO THEIR INTEREST.

TITLE CLOSE TOP DIKED

DWG NO. 72804E

SHEET: 1 OF: 2



Quotation

CUMMINS SOUTHEASTERN POWER INC.  
 2671 Edison Ave.  
 Fort Myers FL 33916 United States  
 Direct: (941)337-1211

August 2, 2004

Project Name: Lee County Fleet Mgmt.

Quotation: 532000000002757

Thank you for your inquiry. We are pleased to quote as follows:

			USD
Item	Description	Qty	
<b>Diesel Genset: 60hZ-350/315kW</b>			
350DFCC	Genset-Diesel,60Hz,350kW	1	
A331-2	Duty Rating-Standby Power	1	
L090-2	LISTING-UL2200	1	
R002-2	Voltage-277/480, 3 Phase Wye	1	
B252-2	Alternator-60 Hz, 12 Lead, Broad Range, 125/105c	1	
H643-2	SET CONTROL-PCC 2100	1	
H536-2	Display Language-English	1	
H606-2	Meters-AC Output,Analog	1	
KP60-2	Interface-CommunicationsNtwk,FTT-10	1	
KM66-2	Circuit Breaker Mtg-Single Brkr,Right of Control	1	
KM46-2	Circuit Breaker-600A,3P,600/690V,SS RMS,80%,UL/IEC	1	
C127-2	Separator-Fuel/Water	1	
F159-2	Unit Profile-Full Width	1	
A334-2	Engine Starter-24 Vdc Motor	1	
A333-2	Battery Charging Alternator-Normal Output	1	
E074-2	Engine Cooling-Radiator, 50c Ambient	1	
E083-2	Engine Exhaust Manifold-Dry	1	
H389-2	Shutdown-Low Coolant Level	1	
H556-2	Coolant Heater-208/240/480v,40f Minimum Ambnt Temp	1	
D041-2	Engine Air Cleaner-Normal Duty	1	
A299-2	Exhaust Connector-Npt	1	
L026-2	Test Record-Certified	1	

L028-2	Genset Warranty-1 Year Base	1
L050-2	Literature-English	1
A322-2	Packing-Skid, Poly Bag	1
CP01-2	Common Parts Listing	1
SPEC-Y	Product Revision - Y	1
0541-0814-02	Annunciator Kit-w/Enclosure	1
0155-2342-02	Critical Muffler-Side Inlet End Outlet-8" ASA Flng	1
0155-2551	Exhaust Pipe Package-Side Inlet-5"NPT to 8"ASA	1
1000 gal	fuel base-tank (UL142)	1
Enclosure	Aluminum Enclosure (150 mpg rated)	1
ST-UP -OTP.26-50 MILES	TRAVEL TIME INCLD. 50 MILES	1
ISC-ST120SN3R/PILNCCB/PILNCOB	EMERGENCY STOP-N3 BREAKGLASS GENSET EM.STOP W NO/NC CONTACT	1
START OPT RMT ANNUNCIATOR	WIRE INTERFACE HARD WIRE	1
START OPT TRANSFER SWITCH	WIRE INTERFACE CONTROL START STOP	2
ST-UP-OTP- BASIC 201-1000 KW 24 VDC	201-1000 KW BASIC START UP	1
ISC-INTERSTATE-8D-XHD	BATTERY SAE8D 1155.CCA. L.A.	2

**Transfer Switch-Power Command: 1600A**

OTPC1600	Transfer Switch-Onan,PwrCmd,1600 Amp	1
A028-7	Poles-3	1
A035-7	Application-Utility To Genset	1
A046-7	Listing-UL 1008/CSA Certification	1
A044-7	Frequency-60 Hertz	1
A042-7	System-3 Phase,3 Wire Or 4 Wire	1
R026-7	Voltage-480 Vac	1
B004-7	Construction - Open	1
C024-7	Control-Transfer Switch,Level 2	1
M018-7	Display-Digital	1
M031-7	Interface-Communications Network,FTT-10	1
K001-7	Battery Charger-2 Amp,12/24 Vdc	1
N008-7	Mechanical Lugs-Cable	1
N013-7	Harness-Extension, 4 Ft, Open Construction	1
G002-7	Transfer Switch Warranty-1 Yr Basic	1
A050-7	Packing-Wooden Crate	1
CP01-7	Common Parts Listing	1
SPEC-A	Product Revision - A	1
Nema 4X	Stainless Steel Cabinet (weather-proof)	1

**Grand Total**

**\$71,494.00**

Submitted by

---

**Jeffery Demars , Energy Sales Manager**

**jeffery.a.demars@cummins.com**

**Mobile: (239) 229-4417**

**Fax: (239) 337-7851**

**Lee County Board Of County Commissioners  
Agenda Item Summary**

Blue Sheet No. 20040772

**1. REQUESTED MOTION:**

**ACTION REQUESTED:** Approve the award of Formal Quotation No. Q-040331, The Annual Purchase of Generators for Facilities Management to the following pool of qualified vendors: Pantropic Power; Cummins Southeastern Power; and Florida Detroit Diesel – Allison. This quotation shall be in effect for one year, or until new quotations are taken and awarded. Also request authority to renew this quotation for four additional one year periods, under the same terms and conditions, if in the best interest of the County, at the expiration of the original term. It is anticipated that as many as 100 generators may be purchased over the next five years. Each purchase will be competitively quoted among the qualified vendors; the award will be to the low quoter and processed per the County's established procedures – for example, if the total cost is over \$50,000, Board approval will be required.

**WHY ACTION IS NECESSARY:** Purchases exceeding \$50,000 require Board approval.

**WHAT ACTION ACCOMPLISHES:** Enables Facilities Management to obtain generators on an as-needed basis from a pre-qualified pool of vendors.

**2. DEPARTMENTAL CATEGORY:  
COMMISSION DISTRICT #**

C2C

**3. MEETING DATE:**

06-29-2004

**4. AGENDA:**

**5. REQUIREMENT/PURPOSE:  
(Specify)**

- CONSENT
- ADMINISTRATIVE
- APPEALS
- PUBLIC
- WALK ON
- TIME REQUIRED:

- STATUTE
- ORDINANCE
- ADMIN. AC-4-1
- CODE
- OTHER

**6. REQUESTOR OF INFORMATION:**

- A. COMMISSIONER \_\_\_\_\_
- B. DEPARTMENT \_\_\_\_\_
- C. DIVISION Facilities Management

BY: Richard Beck, Director

**BACKGROUND:** On April 2, 2004, the Division of Purchasing received a request from Facilities Management to quote the annual purchase of generators. Sealed quotations were received on April, 27, 2004; an evaluation committee met on June 10, 2004 and recommended that Pantropic Power, Cummins Southeastern Power and Florida Detroit Diesel – Allison receive an award and eligibility to quote on upcoming projects.

Funds will be made available on a project specific basis.

**Please see attachments:**

- (1) Tabulation Sheet
- (2) Specifications
- (3) Quotes from Pantropic Power, Cummins Southeastern Power, Florida Detroit Diesel – Allison
- (4) Evaluation Committee Recommendation

**8. MANAGEMENT RECOMMENDATIONS:**

**9. RECOMMENDED APPROVAL:**

A Department Director	B Purchasing or Contracts	C Human Resources	D Other	E County Attorney	F Budget Services	G County Manager
<i>[Signature]</i> 6-10-04	<i>[Signature]</i> 6-10-04			<i>[Signature]</i> 6/10/04	<i>[Signature]</i> 6/10/04	<i>[Signature]</i> 6-10-04

**10. COMMISSION ACTION:**

- APPROVED
- DENIED
- DEFERRED
- OTHER

Rec. by CoAtty  
Date: 6/10/04  
Time: 2:52 PM  
Forwarded To:  
6/10/04 3:59

RECEIVED BY  
COUNTY ADMIN. *[Signature]*  
6/10/04  
4:32 PM SCL  
COUNTY ADMIN  
FORWARDED TO: *[Signature]*  
6-15-04  
5 PM

**MEMORANDUM  
FROM  
THE DIVISION OF PURCHASING**

DATE: August 6, 2004

*Janet Sheehan*

TO: MARILYN RAWLINGS  
FLEET MANAGER

FROM: JANET SHEEHAN, CPPB  
PURCHASING DIRECTOR

RE: BLUE SHEET # 20041033

PROJECT: (1) Generator for Fleet

TYPE: Q-040331

AWARDED TO: Cummins Southeastern, Inc.

Attn. Ms. Rawlings – When you have finished your review of this package, please forward it to Kristie Kroslack in the County Attorney's Office.

If there are any questions or concerns with this package, please contact Bob Franceschini or Chevone Peterson at 344.5450.

REC'D BY  
FLEET SO. ATTORNEY  
AUG 11 2004