

**Lee County Board Of County Commissioners  
Agenda Item Summary**

**Blue Sheet No. 20050505**

**1. ACTION REQUESTED/PURPOSE:**

Approve and authorize the Chairman to sign a contract between Lee County and Tampa Tank, Inc., the low price proposer, meeting all specification requirements for the supply and installation of a field fabricated demineralized water storage tank for an amount of \$87,000.00, all in accordance with RFP B&R 2661-141.

**2. WHAT ACTION ACCOMPLISHES:**

Provides the necessary demineralized water storage tank for the Waste To Energy Expansion Project.

**3. MANAGEMENT RECOMMENDATION:** Staff recommends approval of Action Requested.

**4. Departmental Category:** 8

*C 8 b*

**5. Meeting Date:** April 26, 2005

**6. Agenda:**

- Consent
- Administrative
- Appeals
- Public
- Walk-On

**7. Requirement/Purpose: (specify)**

- Statute
- Ordinance
- Admin. Code 4-4
- Other

**8. Request Initiated:**

Commissioner \_\_\_\_\_  
 Department Public Works  
 Division Solid Waste  
 By: Lindsey J. Sampson

*Lindsey J. Sampson*

**9. Background:**

Sealed quotes were received by the County's design engineer, Burns & Roe, on behalf of the Solid Waste Division on December 30, 2004. On that date five (5) responses were received. After review, recommendation was made to award to the low-priced proposer meeting all specification requirements, Tampa Tank, Inc. for a contract price of \$87,000.00, including the cost for a full payment and performance bond.

Note: Due to the volatility of steel costs, the material price of steel included in this contract (\$12,000) is adjustable to actual cost of material, price per pound, at time of County's release of material placement with a \$2000 cap.

Funds are available in account string: 200923 40102.506540

Attachments: Burns & Roe bid evaluation dated 3/4/05 w/ Tabulation sheet (6 Pages)  
 Contract Document (2 originals)

*↳ 1 orig. w/ signature, 1 copy (x/8)*

**10. Review for Scheduling:**

Department Director	Purchasing or Contracts	Human Resources	Other	County Attorney	Budget Services				County Manager/P.W. Director
					Analyst	Risk	Grants	Mgr.	
<i>Jamie 4.19.05</i>	<i>Quel 4.19.05</i>	<i>N/A</i>			<i>4/13/05</i>	<i>4/12/05</i>	<i>4/13/05</i>	<i>4/13/05</i>	<i>Jamie 4.19.05</i>

**11. Commission Action:**

- Approved
- Deferred
- Denied
- Other

Rec. by CoAtty
Date: <i>4/13/05</i>
Time: <i>10:25</i>
Forwarded To: <i>CC</i>
<i>4/13/05</i>

RECEIVED BY COUNTY ADMIN: <i>SP</i>
<i>4-13-05</i>
<i>1:15 pm</i>
COUNTY ADMIN FORWARDED TO: <i>SP</i>
<i>4-14-05</i>
<i>9 am</i>



March 4, 2005

**LEE COUNTY  
WTE EXPANSION PROJECT  
FORT MYERS, FLORIDA**

**RFP 2661-SM141**

**FIELD ERECTED DEMINERALIZED WATER STORAGE TANK**

**BID EVALUATION**

On December 30, 2004, Burns and Roe Enterprises, acting on behalf of Lee County issued Request for Proposal No. 2661-SM 141 "Field Erected Demineralized Water Storage Tank" to the following pre-approved bidders: Chattanooga Boiler & Tank Co., Fisher Tank Co., Matrix Service Industrial Contractors, Inc., RECO Constructors, Inc., Tampa Tank, Inc.

**On January 28, 2005 bids were received from:**

1. Chattanooga Boiler & Tank - Proposal # CBT 05-009, dated 1/20/05
2. Fisher Tank Company - Proposal # 05057, dated 1/28/05
3. Matrix Service Industrial - Contractors, Inc. Proposal # 302-5-04-239, dated 1/27/05
4. RECO Constructors, Inc. - Proposal # 050102, dated 1/28/05
5. Tampa Tank, Inc. - Proposal # 4089, dated 1/28/05

**RECOMMENDATION:**

The recommended award of the contract is to Tampa Tank, Inc, the low bidder, for the Demineralized Water Storage Tank, for the Base Case of Carbon Steel, Plasite Lined based on the technical evaluation, evaluated price analysis and comments herein. Award price includes 100% Performance and Payment Bonds, FOB Jobsite, Freight Prepaid and Allowed, and does not include Sales or Use Tax. Note the material cost of \$12,000 is adjustable to actual cost of material (price per pound) at time of material order placement:

Recommended Award Price:

\$ 87,000.00

**COMMERCIAL EVALUATION:**

In addition, to the Base Case, Bidders were requested to provide alternate prices for the Demineralized Water Storage Tank to be fabricated from 304 and 316 Stainless Steel. All Bidders, except Fisher Tank, provided alternate pricing, as requested, and have been tabulated accordingly. Subsequently, Covanta and Lee County decided on a carbon steel lined tank.

Upon initial evaluation, no further consideration was given Chattanooga Boiler and Fisher Tank due to the relatively higher pricing, compared to the remaining three (3) bidders. Additionally, and due to recent fluctuations in material costs the Bidders, with the exception of Fisher, have taken exception to our request for firm lump sum pricing and have proposed various escalation terms.

Bid conditioning questions were prepared and sent to each of the (3) remaining lowest bidders, Tampa Tank, RECO and Matrix Service, for the Base Case, to further clarify technical issues/exceptions taken by each of the Bidders.

The questions and Bidders responses have been evaluated and the impact as a result, of same, are as shown in the Abstract, with dollar adjustments made as applicable.

Further discussions were conducted only with Tampa Tank due to their economic position, and being technically acceptable.

**Tampa Tank** took exception to the Insurance Article (liability coverage) and Warranty.

-Tampa's excess liability coverage of \$9,000,000 is deemed acceptable. Copy of Tampa's insurance certificate is attached.

-Tampa's warranty including the lining for one year of operation. This is also acceptable.

-Tampa's coating subcontractor is Pop's Painting. Pop's Painting has more than twenty years experience and attached are two reference checks.

-Approval drawings will be submitted four weeks after placing order. Site erection is not required till April 15, 2006, resulting in a six-month float prior to ordering material.

-Tampa Tank, as all bidders, requires price adjustment on material. Tampa Tank's total material cost is \$12,000. Tampa advised total carbon steel weight of 23,600 pounds. Price at time of bid is \$0.47 per pound. The \$12,000 material cost would be adjusted at material order placement based on actual per pound cost of material.

-Tampa requested a progress payment of:

- submission of bonds
- completion of engineering/drawing approval
- delivery of material to jobsite
- monthly progress after site mobilization.

This is acceptable.

-Tampa quoted 30% and 40% multiplier for potential additional work. Tampa subsequently reduced to 15% and 20%. This is acceptable.

-Tampa Tank visited the jobsite to review new tank location, and 138kV overhead lines, and clearance. Tampa responded on 3/4/05 stating not a problem and will impact their erection.

-Tampa issued and acknowledged receipt and incorporated in bid the updated Wind conditions.

**TECHNICAL EVALUATION**

RECO bid API 650 for the carbon steel tank in lieu of the specified AWWA-D-100. Until clarification is received from RECO that they will be in compliance with AWWA-D-100, their bid is considered technically unacceptable.

Tampa was asked to confirm the inclusion of internal SS piping in their offering as required by the Specification. They have indicated that it is included. They have also included the specified internal epoxy coating.

Matrix was asked to give a deduct for the final exterior coating of the tank which was not specified but included by them in their scope of work. They have stated that the deduct is \$3,465.

Tampa is the low technically acceptable bidder with a bid price of \$87,000. The stainless steel low option price is from Matrix utilizing 304SS as the material. Their SS option price is \$118,000, which is \$31,000 more than the lowest carbon steel tank price from Tampa. BRE does not see any justification utilizing SS in this size tank based on the price differential and on the current maintenance performed on the existing Lee County Demineralized Water Storage Tank.

BREI therefore recommends that the award be given for the Field Erected Demineralized Water Storage Tank to Tampa Tank.

**ATTACHMENTS:**

1. Proposal Opening Form
2. Bid Abstract
3. Email BRE to Tampa 2/3/05
4. Email Tampa to BRE 2/9/05
5. Email BRE to Tampa 2/10/05
6. Email Tampa to BRE 2/17/05
7. Tampa Tank's Insurance Certificate
8. Email BRE to Tampa 2/24/05
9. Email 2/28/05 concerning Pop's Painting
10. Two (2) telephone records 2/18/05, Pop's Painting reference checks.
11. Email Tampa to BRE 3/4/05 (site visit; payment terms; revised mark-up percentages).

LEE COUNTY, FLORIDA  
PROPOSAL OPENING FORM

RFP NUMBER SM-141

TITLE Fill and Embed Tanks

DATE 1.31.05

TIME 12:30pm

Bidder	Proposal Date	Date Received	Base Unevaluated Price	Remarks
1 * RECO	1.28.05	1.28.05	\$109,399	30455 / 119,807 30455 / 141,005 31655
2 * MATRIX	1.27.05	1.28.05	\$118,130	118,000 / \$143,000
3 * Fisher Tank	1.28.05	1.28.05	\$123,780	No bid / No bid
4 * Chattanooga	1.20.05	1.21.05	\$145,740	147,750 Coil / \$164,840 Coil \$157,800 Plate / \$183,940 Plate
5 * TAMPA Tank	1.28.05	1.28.05	\$87,000	130,600 / \$161,800

OPENED BY: D. D'Amico 1/31/05  
WITNESSES: Robert Spencer 1/31/05

BID ABSTRACT		FIELD ERECTED DEMINERALIZATION TANK											
Burns and Roe Enterprises, Inc.		Chattanooga		Fisher Tank		Matrix		RECO		Tampa Tank			
W/O: 2661 Lee County Expansion Project RFP No. SM-141 Field Erect Tank		BUDGET: \$77,484.		1		2		3		4		5	
ITEM	QTY	UNIT	DESCRIPTION	Included	30 days	Included	No	Included	No	Included	No	Included	No
1	1	ea	Demineralized Water Tank	\$ 145,740.00	\$ 123,750.00	\$ 118,130.00	\$ 109,399.00	\$ 87,000.00					
			Field Erected, Carbon Steel,										
			Plasite Lined (50,000gal)										
			Perform./Payment Bond	Included		Included		Included		Included		Included	
			Pricing Firm	No		No		No		No		No	
			BID CONDITIONING:										
			Supply power and water	Owner		Owner		Owner		Owner		Owner	
			Wind: 130mph & 1.00 Importance	Yes		Yes		Yes		Yes		Yes	
			Design/Fab to AWWA-D100	Yes		Yes		NO		NO		Yes	
			Internal ss Piping as Specified	Included		Included		Included		Included		Included	
			Delete Finish Coat External CS	n/a		n/a		n/a		n/a		n/a	
			Recommended Award Price	\$ 145,740.00	\$ 123,750.00	\$ 114,665.00	\$ 109,399.00	\$ 87,000.00					
				+67%	+42%	+30%	+25%	base					
			Freight F.O.B. Jobsite	Included		Included		Included		Included		Included	
			Drawings Submitted	4 wks ARO	2-4wks ARO	4wks ARO	2-4wks ARO	4wks ARO		2-4wks ARO		4wks ARO	
			Delivery of material	5-6wks after mat'l order	6wks ARO	6wks	3wks	12wks ADA		3-4wks		3-4wks	
			Erection Duration	Progress, net 30	Progress net 30	Progress net 30	Progress net 30	Bond, Engrg. progress, n30		Fort Myers, Fl.		Fort Myers, Fl.	
			PAYMENT TERMS	Fort Myers, Fl.	Fort Myers, Fl.	Fort Myers, Fl.	Fort Myers, Fl.	Fort Myers, Fl.		Fort Myers, Fl.		Fort Myers, Fl.	
			DESTINATION										
			ALTERNATES (not accepted)	S/S see page 2	S/S see page 2	S/S see page 2	S/S see page 2	S/S see page 2		S/S see page 2		S/S see page 2	
			AWARD RECOMMENDATION: Tampa Tank										
			REASON FOR RECOMMENDATION: Price, locale										
				PREPARED BY:	DAMICO	DATE:	3/3/2005						
				REVIEWED BY:		DATE:							

DEMIN. WATER TANK	Chattanooga	Fisher Tank	Matrix	RECO	Tampa Tank
BASE - Carbon Steel Lined					
Field Erected Demin. Water Storage Tank					
Engineering	\$ 5,000.00	\$ 8,948.00	\$ 6,930.00	\$ 5,400.00	\$ 3,500.00
Material	\$ 26,000.00	\$ 18,287.00	\$ 18,530.00	\$ 21,000.00	\$ 12,000.00
Shop Fabrication	\$ 18,700.00	\$ 10,087.00	\$ 8,109.00	\$ 8,800.00	\$ 13,000.00
Shop Prime Coat	\$ 5,600.00	\$ 2,305.00	\$ 8,800.00	\$ 3,080.00	\$ 3,000.00
Mobilization	\$ 7,500.00	\$ 8,131.00	\$ 6,692.00	\$ 10,800.00	\$ 4,500.00
Construction	\$ 15,000.00	\$ 18,314.00	\$ 9,837.00	\$ 4,500.00	\$ 3,000.00
Equipment	\$ 35,700.00	\$ 24,831.00	\$ 30,366.00	\$ 18,936.00	\$ 27,000.00
Field Erection	\$ 24,000.00	\$ 25,461.00	\$ 22,000.00	\$ 23,000.00	\$ 14,000.00
Plasite Lining	Included In	\$ 1,117.00	\$ 880.00	Included	\$ 3,500.00
Testing	\$ 7,500.00	Included		\$ 10,800.00	\$ 1,500.00
Demobilization	Included In	\$ 4,966.00	\$ 7,286.00	\$ 2,000.00	\$ 500.00
Freight FOB Site					
Subtotal	\$ 145,000.00	\$ 122,548.00	\$ 117,430.00	\$ 108,316.00	\$ 85,500.00
Performance Bond	\$ 740.00	\$ 1,202.00	\$ 700.00	\$ 1,083.00	\$ 1,500.00
TOTAL	\$ 145,740.00	\$ 123,750.00	\$ 118,130.00	\$ 109,399.00	\$ 87,000.00
ALTERNATES:					
304 Stainless Steel in lieu of Carbon Steel	Coil \$ 147,750.00	no bid	\$ 118,000.00	\$ 119,807.00	\$ 130,600.00
	Plate \$ 157,800.00				
316 Stainless Steel in lieu of Carbon Steel	Coil \$ 164,840.00	no bid	\$ 143,000.00	\$ 141,005.00	\$ 161,800.00
	Plate \$ 183,940.00				

**CONTRACT**

**BETWEEN**

**LEE COUNTY, FLORIDA**

**AND**

**TAMPA TANK, Inc.**

**FOR**

**SUPPLY AND CONSTRUCTION SERVICES**

**OF**

**FIELD FABRICATED STEEL TANK**



## CONTENTS

ARTICLES	<u>PAGE</u>
1. Definitions	
1.1 Acceptance Testing .....	1
1.2 Affiliate Company.....	1
1.3 Applicable Law .....	1
1.4 Change Order.....	1
1.5 Consulting Engineer. ....	2
1.6 Contract .....	2
1.7 Contract Price.....	2
1.8 County Contractor(s).....	2
1.9 Covanta.....	2
1.10 Design. ....	2
1.11 Engineer. ....	2
1.12 "Equal", "or Equal" or "Equivalent".....	2
1.13 Existing Facility.....	2
1.14 Force Majeure.....	2
1.15 Notice. ....	2
1.16 Notice-to-Proceed.....	3
1.17 Party or Parties.....	3
1.18 Product. ....	3
1.19 Project. ....	3
1.20 Project Schedule.....	3
1.21 Schedule.....	3
1.22 Site (or Jobsite).....	3
1.23 Subcontractor.....	3
1.24 Work.....	3
2. Contractor Obligations	
2.1 General.....	4
2.2 Purchases.....	4
2.3 Construction. ....	4
2.4 Coordination and Cooperation.....	4
2.5 Site Conditions.....	5
2.6 Care, Custody and Control. ....	6
2.7 Document Deliverables.....	6
2.8 Subcontractors.....	6
2.9 Labor Relations/Host Community. ....	6
2.10 Reporting. ....	6
2.11 Approvals, Permits and Licenses.....	7
2.12 Safety, Health and Cleanliness at Site.....	7
2.13 Contractor Personnel.....	8
2.14 Contractor's Equipment and Tools.....	8
2.15 Taxes and Contributions.....	8
2.16 Inspection of Site and Project.....	8
3. Commencement, Completion, Testing, Acceptance and Damages	
3.1 Time and Order of Work; Earlier Completion.....	10
3.2 Notice To Proceed.....	10
3.3 Completion of Work and Liquidated Damages .....	10
3.4 Interim Checkout.....	11
3.5 Phased Systems Turnover. ....	11
3.6 Certificate of Occupancy.....	11
3.7 Acceptance of Work.....	11

ARTICLES

PAGE

4.	Contract Price	
4.1	Contract Price .....	12
4.2	Progress Payments .....	12
4.3	Invoicing .....	12
4.4	Retainage .....	12
4.5	Retainage for Punch List Items.....	12
4.6	Final Payment.....	12
4.7	Representation .....	13
4.8	Liens.....	13
5.	Guarantees and Warranties	
5.1	General Warranty .....	14
5.2	Latent Defects.....	14
5.3	Equipment and Materials Warranty.....	14
5.4	Performance Guarantees, Testing and Damages .....	14
5.5	Limitation of Warranties and Remedies.....	14
6.	Indemnification, Bonds and Insurances	
6.1	Indemnification.....	15
6.2	Labor/Material and Performance Completion Bond.....	15
6.3	Insurances.....	15
	6.3.1 Workers' Compensation Insurance.....	15
	6.3.2 Employer's Liability Insurance.....	15
	6.3.3 Comprehensive General Liability Insurance.....	15
	6.3.4 Comprehensive Automobile Liability Coverage .....	16
	6.3.5 Excess Liability Coverage.....	16
	6.3.6 Builders "All Risk" .....	16
	6.3.7 Waiver of Subrogation/Recourse.....	16
	6.3.8 Certificates.....	16
	6.3.9 Subcontractors.....	16
	6.3.10 Insurance in Force .....	16
7.	Changes	
7.1	Discretionary Rights of County.....	17
7.2	Change Orders.....	17
7.3	Pricing .....	17
7.4	Payment .....	17
7.5	Change Orders Not Allowed.....	17
7.6	Duty to Continue Work.....	18
8.	Termination and Suspension	
8.1	County Right to Terminate.....	19
8.2	Termination for Default .....	19
8.3	Termination for Convenience.....	19
8.4	Action Upon Termination .....	19
8.5	County Right to Suspend.....	20

ARTICLES

PAGE

9. County Responsibilities

9.1 General Specification.....21

9.2 Site.....21

9.3 Permits; Licenses; Approvals.....21

9.4 Project Manager.....21

10. Confidentiality and Nondisclosure

10.1 Confidential Information.....22

10.2 Subcontractors, Vendors and Employees of Contractor.....22

10.3 Inventions and Improvements.....22

10.4 Ownership and Disposition.....22

10.5 Publicity.....23

10.6 Remedies for Breach.....23

10.7 Duration of Obligations.....23

11. General Provisions and Covenants

11.1 Compliance with Applicable Law: Postings.....24

11.2 Business Standards.....24

11.3 Title.....24

11.4 Force Majeure.....24

11.5 Disputes and Claims.....25

11.6 Infringement of Proprietary Rights.....25

11.7 Firearms, Drugs and Alcohol.....25

11.8 Assignment.....25

11.9 Relationship of the Parties.....25

11.10 Nondiscrimination in Employment.....25

11.11 Notices.....26

11.12 Law/Jurisdiction.....26

11.13 Entire and Complete Contract.....27

11.14 Binding Effect.....27

11.15 Other Documents.....27

11.16 Waiver.....27

11.17 Visitors, Photographs, Security.....27

11.18 Third Party Rights.....27

11.19 Severability.....27

11.20 Survival of Obligations.....27

11.21 Headings.....27

11.22 Counterparts.....27

## EXHIBITS

Exhibits, Attachments, and Schedules attached and incorporated by reference.

- A. General Construction Requirements
- B. Design – Conformed Plans and Specifications Technical Specification 2661-SM141 “Field Fabricated Steel Tanks”, dated 3/22/05
- C. Payment Procedures
- D. Project and Contract Schedule)
- E. Scheduling and Progress Reporting Procedures
- F. (NOT USED)
- G. Covanta Contractor Safety Requirements
- H. (NOT USED)
- I. Rates for Time and Material Work
- J. Approved Subcontractors and Vendors
- K. Lee County DM/DWBE Rules (later)
- L. (NOT USED)
- M. Form of Contractor's Affidavit, Waiver of Liens and Release
- N. Form of Labor and Material Payment and Performance Completion/Bonds

## CONTRACT

THIS CONTRACT is made and entered into as of the \_\_\_\_ day of \_\_\_\_\_, 20\_\_ by and between Lee County, Florida, a political subdivision and charter county of the State of Florida (hereinafter "County" or "Purchaser"), and Tampa Tank, Inc., a Florida corporation (hereinafter "Contractor" which shall also include its contractors and vendors on any tier). The Exhibits referenced herein and attached hereto are an integral part of this Contract.

### RECITALS:

County owns a municipal waste-to-energy power facility located at Buckingham Road in the County (the "Existing Facility"), which is operated and maintained by Covanta Lee, Inc. ("Covanta"), and desires to expand the Existing Facility. In connection with the expansion, County desires to engage Contractor to provide equipment, materials, construction and other services as hereinafter defined and Contractor, representing it is fully capable and prepared to do so, desires to provide such services.

Therefore, in consideration of the premises, undertakings, promises, covenants and conditions contained herein, the sufficiency of which is hereby acknowledged, the Parties agree as follows:

### ARTICLE 1

#### DEFINITIONS

The following definitions are of certain terms used in this Contract. All other terms shall have the meanings given by their use in the text. The words "include" or "including" shall be deemed to be followed by the phrase "without limitation", except where the context would not warrant.

#### 1.1 Acceptance Testing

"Acceptance Testing" means the testing activities performed on the Project to determine, in accordance with this Contract, whether Contractor has properly supplied, equipped, installed, erected, assembled, constructed and mechanically and functionally checked and tested its Work.

#### 1.2 Affiliate Company

"Affiliate Company" means a corporation or other business entity directly or indirectly controlled by, controlling or under common control of a Party.

#### 1.3 Applicable Law

"Applicable Law" means any law, ordinance, rule, regulation, code, requirement, permit, judgment or order of any federal, state or local agency, court or other governmental body or entity having jurisdiction over the Work or the Parties and includes the permits, licenses and governmental approvals applicable to the acquisition, design, construction, equipping, start-up, testing, financing, ownership, possession or operation of the Project or the performance of any obligations under this Contract.

#### 1.4 Change Order

"Change Order" means the method, procedure and document by which this Contract, its terms, conditions, Exhibits, schedules and text may be modified, adjusted or amended in accordance with and as defined and described in Article 7. Valid Change Orders shall form a part of this Contract and shall be governed by, and be enforceable in accordance with, the terms hereof unless specifically provided otherwise in the Change Order.

1.5 Consulting Engineer

"Consulting Engineer" means the firm(s) retained by County to review and monitor the content, quality, progress of the Project and such other activities as may be entrusted to it.

1.6 Contract

"Contract" means this principal document, the Exhibits, schedules, amendments, and Change Orders.

1.7 Contract Price

"Contract Price" shall mean the fixed remuneration to be paid to Contractor for its satisfactory performance, including any adjustments made by Change Order.

1.8 County Contractor(s)

"County Contractor(s)" shall mean those contractors and suppliers (other than the Contractor) with whom County contracts separately.

1.9 Covanta

"Covanta" shall mean Covanta Lee, Inc., the firm that operates and maintains the Existing Facility and the firm that the County has contracted, or intends to contract for (a) services to oversee the design of the Project, (b) services to manage the construction and equipment supply of the Project, and (c) upon completion of the design and construction, to start-up, test, operate and maintain the Project.

1.10 Design

"Design" means the collection of technical and non-technical information, design parameters, design standards, plans, specifications, drawings, documents, environmental and other permits and such other information provided or to be provided by County to Contractor including, but not necessarily limited to the Exhibits to this Contract, which information is intended to generally describe the Work, Project, Existing Facility, Site, Schedule requirements and the supply and construction activities to be performed by Contractor.

1.11 Engineer

"Engineer" means Burns & Roe Enterprises, Inc., the firm County has contracted with to provide the detailed design and engineering for the Project.

1.12 "Equal", "or Equal" or "Equivalent"

Whenever materials, products or equipment are designated by manufacturer's or vendor's names, trade names, catalog numbers, etc., such designation is intended to establish a standard. When such designation is modified by the words "equal", "or equal", or "equivalent", other materials, products or equipment which meet the established standard may be used, provided that their equivalency has been demonstrated by the Contractor to the satisfaction of County and written consent for their substitution has been obtained from County.

1.13 Existing Facility

"Existing Facility" has the meaning given that term in the Recitals.

1.14 Force Majeure

"Force Majeure" shall have the meaning given in Article 11.4.

1.15 Notice

"Notice" means formal written notice given in accordance with Section 11.11.

1.16 Notice to Proceed

"Notice to Proceed" means the formal written direction from County to Contractor to commence the Work on the Project.

1.17 Party or Parties

"Party or Parties" means County and Contractor or one of them as the context requires.

1.18 Product

"Product" means all design, deliverables, materials, equipment, systems, machinery, supplies, documentation, testing procedures, and other items related to or to be incorporated into the Work.

1.19 Project

"Project" means the Product, Work and a third total mass-burn solid waste resource recovery unit to be constructed for the County and integrated into the Existing Facility, including enhancements to the Existing Facility, all as described in the Exhibits and includes the whole of the Work undertaken to be performed by the Contractor pursuant to this Contract. The Project includes the facilities and equipment off the Site, if any, for which the Contractor is responsible as per the Exhibits.

1.20 Project Schedule

"Project Schedule" or "Master Project Schedule" mean the time schedule of the Project as further described in the Exhibits.

1.21 Schedule

"Schedule" means the time schedule of the Work as further described in the Exhibits.

1.22 Site (or Jobsite)

"Site" or "Jobsite" means the area on which the Project is to be located and/or Contractor's area of responsibility as more particularly described in the Exhibits.

1.23 Subcontractor

"Subcontractor" means any person or entity, such as Subcontractors, or supplies of any tier, under contract with the Contractor to provide any part of the Work, including any Product.

1.24 Work

"Work" means the whole of the undertakings to be performed by the Contractor pursuant to this Contract as described in the Exhibits, including without limitation procurement, equipping, assembly, installation, erection, construction, and testing services. Contractor shall continually furnish as required all administration, supervision, management, consultations, Product, equipment, materials, supplies, labor, construction tools and equipment, chemicals, lubricants and other consumables (other than those for the continuous operation of the Project), temporary and permanent utilities, storage, temporary buildings and facilities, transportation including, without limitation, hauling, unloading and handling at, to and from the place(s) of Work, all in order for the Project to be complete, operable, and ready for safe and reliable sustained commercial operation in accordance with this Contract.

END OF ARTICLE

## ARTICLE 2

### CONTRACTOR OBLIGATIONS

#### 2.1 General

2.1.1 Contractor shall supply and provide all equipment, materials, management, supervision, labor, construction, testing, utilities, construction tools and equipment, supplies, consumables, temporary structures and facilities, and all transport and handling necessary to complete the Work and perform the Contract in its entirety.

2.1.2 Contractor has represented and herein confirms that it is experienced in the supply and construction of the Project or of similar facilities, understands and has estimated the cost of its labor, materials and equipment, and the time required to complete the Work. Contractor understands and accepts the full risks of costs and schedule and agrees that it will make no claims for additional compensation or extension of time except as specifically allowed by the terms of this Contract. Except for bonafide additions to the Work by Change Orders made in accordance with Article 7, no requests or claims for any other increase in the Contract Price based upon mistake, constructive change, delay, acceleration or force majeure shall be allowed.

2.1.3 The several documents forming the Contract shall be taken as mutually explanatory of one another. In the event of any conflict, variation or inconsistency between any provision of the body of this Contract and any provision of any Exhibit, the provisions of the body of this Contract shall control. Anything shown in the Design and not specifically shown in any proposal drawings, or vice versa, shall be of like effect as if shown in both. Anything shown or mentioned in the Design documents or other related or pertinent written documentation and not shown on drawings or plans, or shown on drawings or plans but not mentioned in the Design or other related or pertinent written documentation, shall be of like effect as if mentioned in each or any of them. In case of discrepancy between any proposal drawings and the Design, the Design shall prevail. Contractor acknowledges that it is fully familiar with this Contract, including the requirements in the Exhibits. It shall be Contractor's responsibility to notify County and Covanta, without delay, of any material errors, omissions or discrepancies that Contractor exercising reasonable diligence may discover. Contractor shall not be relieved of any of its obligations or liabilities for failure to discover such errors or omissions. Ambiguities, discrepancies or inconsistencies shall be adjusted by County who shall issue Contractor instructions with respect thereto.

#### 2.2 Purchases

Except for purchases to be made by County as set forth in the Exhibits, Contractor shall procure all necessary equipment and materials and be responsible for the quality and adequacy and performance of, and making timely and full payment for all such Contractor purchased materials and equipment.

#### 2.3 Construction

Contractor shall deliver, assemble and install the equipment, and complete the Work. Contractor's construction obligations shall include the management and coordination of all construction activities including, health and safety, construction equipment and tools, consumables, supervision, labor, deliveries, handing, storage, installation, and testing. Contractor shall provide and maintain appropriate protection and storage for all equipment and materials, including any equipment and materials supplied to Contractor by County, all temporary construction aids on the Site and for the removal and proper disposal of all excess soil, gravel or other unusable materials.

#### 2.4 Coordination and Cooperation

2.4.1 Included in the management of its Work on the Project, Contractor shall be responsible for coordinating the activities of all of its Subcontractors and suppliers, including, but not limited to, subcontractors and suppliers assigned to Contractor by County, if any. Contractor shall be knowledgeable of the plans, schedules and activities of all contractors and suppliers; monitor and review progress, and safety practices to assure conformance to OSHA, Contractor's and Covanta's safety program; conduct periodic on-Site coordination meetings with all participants, keeping minutes and records thereof, copies of which shall be furnished to Covanta and County; provide consultation and advice on maintaining maximum labor productivity; develop and implement strategies to maintain (or possibly shorten) Contractor's Schedule and/or the Project Schedule.



2.4.2 Contractor shall cooperate with the County, Covanta, and other County Contractors, to ensure that the Work is properly performed on schedule. Contractor shall collaborate with Covanta and any other County Contractors and coordinate its Work with the work of such other County Contractor(s), which could affect Contractor's Work, and Contractor shall proceed in such manner as not to interfere or delay the progress of the Project as a whole.

2.4.3 If any part of the Contractor's Work depends for proper execution or results upon the work of any other County Contractor(s), the Contractor shall inspect and promptly report in writing to the County and Covanta any defects in the work of such other contractor that renders it unsuitable for such proper execution or results. Failure of the Contractor to do so shall constitute its acceptance of the other County Contractors' work as fit and proper for the reception of Contractor's Work, except as to defects that may develop in the other County Contractors' work after the execution of the Contractor's Work.

2.4.4 In cases of disagreement or disputes between the Contractor and other County Contractor(s) which could delay or interfere with Contractor's Work due to the failure to collaborate and cooperate or which cannot be resolved between Contractor and the others involved, the County and Covanta shall be given prompt written notice specifying in detail the disagreement or dispute. In such cases, the County shall have the right to determine the proper method of coordinating the Contractor's Work, and the County's decisions in this regard shall be final, binding, and conclusive.

2.4.5 The Contractor shall provide an on-site representative duly authorized to act for and on behalf of the Contractor and to commit to decisions that shall be binding on the Contractor. If requested, said representative shall attend meetings which may be called by the County. Notwithstanding the existence of a dispute or disagreement between the County and the Contractor, the Contractor shall diligently and without interruption proceed with its Work at such rates of progress as will ensure full completion of its Work on time.

2.4.6 County or Covanta shall have the right to perform work with its own employees or by other contractors and to permit other entities to do work during the progress and within the limits of, or adjacent to, the Work site, and the Contractor shall conduct its Work and cooperate with all others so as to mitigate any possible interference. The Contractor shall allow other contractors, including County Contractors, or other entities access to their work within the Work site. The Contractor shall make no claims against County for additional payment due to delays or other conditions created by the operations of such other parties.

2.4.7 Contractor acknowledges that (a) its rights and remedies under this Contract can be enforced only against the County and (b) under no circumstances shall Contractor be permitted to pursue any rights or remedies against Covanta.

## 2.5 Site Conditions

2.5.1 Contractor represents that it has investigated and knows the nature and scope of the Project, the location and peculiarities of the Site, and Contractor's particular area of activity, including accessibility, the type and magnitude of the labor, the character and quantity of equipment, tools, materials and facilities required, the Product and the general and local conditions and matters which could affect its Work, including Contractor's activities yielding priority to the continuous activities of others supporting the critical operation and maintenance of the Existing Facility. Contractor represents that it has reviewed the geotechnical and other information made available to it by County or otherwise generally available to Contractor regarding the soil, topography, underground and groundwater conditions as well as such other conditions that might affect the progress and cost of its Work, has satisfied itself as to those conditions and accepts the risks associated therewith. Contractor's failure to become knowledgeable about or to discover material matters which affect its Work or the Project shall not relieve Contractor from its obligations under this Contract.

2.5.2 Contractor shall check against the Design documents all existing dimensions of consequence to its Work prior to any performance of such related Work, including points of interface with the Existing Facility, work of other County Contractors, or equipment supplied to Contractor by County. Contractor shall be responsible for any errors which can be discovered by examination or checking of the Design documents, and the Contractor shall be responsible for the joining and fitting of all parts of the Work, and any checking or inspection by the County or its representatives shall not relieve Contractor of any responsibility as to the correctness of any work.

## 2.6 Care, Custody and Control

Contractor shall be entrusted with the care, custody and control of the Product and of the Work in progress, including any information and data, equipment, materials and supplies furnished by County, Covanta and County Contractors and delivered to Contractor, and of the Product. Contractor shall provide for any proper storage, care, security and protection (particularly protection from damage or loss due to inclement weather) and shall be responsible for any loss or damage while in its care. County may take temporary custody of and use partially completed parts of the Project. Such temporary custody shall not be deemed an acknowledgment of Completion or Acceptance.

## 2.7 Document Deliverables

In a timely manner before the Work is complete, Contractor shall, provide copies of project equipment data books, operation and maintenance instruction manuals, document and drawing indexes, control keys, computer programs and access codes, computer disks and the like for Contractor-supplied equipment containing the information necessary to enable Covanta to properly start-up, operate and maintain the Project in accordance with generally accepted standards of practice in the industry and Applicable Law, including environmental, safety and other governmental standards, guidelines and regulations. Such data books, manuals and programs shall include the procedures for start-up, shutdown, emergency operation, maintenance schedules and procedure, and other related information. Before Acceptance, Contractor shall also provide Covanta and the County with copies of all warranties relating to equipment and systems installed by Contractor, recommended spare parts lists for all Product, vendor's prints, manufacturers' equipment descriptions, specific information on each component of the Product, Computer Aided Design and Drafting (CADD) work products (including disks and electronic data records) and a complete set of "as-built" reproducible record drawings incorporating and reflecting all changes.

## 2.8 Subcontractors

2.8.1 Contractor shall not be permitted to subcontract the whole of its Work. Contractor may subcontract portions thereof, provided that the Contractor shall remain responsible and liable to County for any Work so subcontracted. No privity of contract shall be created between County and any Subcontractor or supplier. Should such parties institute a claim or commence a suit directly against County, Contractor shall defend, indemnify and pay any expenses incurred by County including attorney's fees to the fullest extent permitted by law. The Contractor shall assure that contracts with its contractors or suppliers are assignable to County and contain warranties and remedies for default at least to the extent that Contractor is so bound. At regular intervals, Contractor shall review with Covanta and County each such Subcontractor's or supplier's progress and performance.

2.8.2 The Contractor shall select major Subcontractors and suppliers from a list of acceptable Subcontractors and suppliers submitted to County. Reviews or approvals by County of subcontracts, Subcontractors or vendors shall be made as promptly as possible. Such reviews shall not and will not create any contractual relationship between County and any Subcontractor or supplier, relieve Contractor of any of its obligations under the Contract or constitute a representation by County that a Subcontractor or supplier is qualified.

2.8.3 No privity of contract shall be created by virtue of this Contract between County and any Subcontractor or supplier.

## 2.9 Labor Relations/Host Community

To the extent that it is practicable and consistent with the efficient performance of this Contract, labor and other services employed at the Site shall be obtained from the community hosting the Project or otherwise available in the vicinity. Although the Contractor reserves the right of hiring, discharging and designating the classification of work for each employee or of shop or field fabrication of material in accordance with its best judgment, Contractor shall take responsible care in its selection of the work force, contractors, Product and procedures to maximize productivity and to avoid slow-downs, work stoppages or other disruptive concerted action.

## 2.10 Reporting

Employing the reporting procedure and format set forth in the Exhibits, Contractor shall submit monthly progress reports certifying progress including percentages of equipment purchased, on site or installed, milestones reached, manpower, significant events which occurred during the month, Work to be performed and milestones to be achieved during the coming month, documents and updates relating to Schedule and minutes of meetings with Subcontractors and suppliers. Information from these reports shall be used to determine progress for payment purposes. In addition, Contractor's Project Manager, Construction Superintendent (and when appropriate, Start-up Coordinator) shall meet regularly with County and Covanta to review progress, discuss the reports and resolve any problems.

## 2.11 Approvals, Permits and Licenses

Except as specifically designated or obtained by others, Contractor at its expense shall obtain and maintain all registrations, permits, licenses and approvals necessary for the Contractor to fulfill its obligations under the Contract. Contractor and its Subcontractors shall submit evidence to County of valid licenses or permits to operate in the jurisdiction of the Project and post them as may be required.

## 2.12 Safety, Health and Cleanliness at Site

2.12.1 County requires Contractor to place the greatest importance and highest priority on safety and health during performance. Contractor shall be responsible for initiating, maintaining and supervising all safety measures and programs, including the conduct of regular safety meetings with employees, all contractors and Subcontractors, and shall take all necessary measures to ensure that all contractors, Subcontractors and suppliers provide and maintain a safe working environment, properly protecting all persons on and in proximity of the Site from risk of injury and danger to health and all property from damage or loss.

2.12.2 Before starting Work on the Site, Contractor shall prominently post and disseminate safety, fire and other health regulations in compliance with Applicable Law, Covanta's health and safety rules and its own safety rules and requirements, which are attached as part of Exhibit G. Contractor shall ensure that its employees and employees of all contractors and Subcontractors, at the commencement and throughout their employment at the Site, are kept aware of all safety and health regulations and are informed that full compliance therewith is a condition of their continued employment on the Project.

2.12.3 Contractor shall ensure that construction tools and equipment, materials, temporary facilities and other items, whether purchased, rented, or otherwise provided by Contractor and its Subcontractors are in a safe condition and capable of performing their function. The use of lead paint and asbestos is always prohibited.

2.12.4 Contractor shall take all precautions necessary for the safety of the Project or any component thereof, and for the security of the Site by providing and maintaining protective fencing, lights, guards, warning and informational signs, temporary passages and roadways or other safety aids and protections appropriate to such purposes in full compliance with proper construction practices, OSHA and other Applicable Law regarding the maintenance of a safe work place.

2.12.5 Contractor shall at all time keep its Work areas, including applicable adjoining premises, driveways and streets safe and clear of snow, ice, mud, construction materials and rubbish. Promptly upon Completion, Contractor shall remove all of its remaining materials and rubbish from and about the premises, leaving the area safe, clean and ready for use. Contractor shall dispose of all waste materials and rubbish in accordance with Applicable Law. If Contractor is notified to clean up and remove its construction debris, or the use of unsafe tools or equipment, and fails to correct the matter within two (2) business days, County shall have the right to correct the matter and deduct the costs from any amounts (including retainage) that may be due Contractor.

2.12.6 Contractor shall not permit a hazardous, unsafe, unhealthful or environmentally unsound practice, procedure condition and/or activity to exist or be conducted at the Site. As soon as Contractor becomes aware of any such unsound practices, procedures, and/or conditions for which it is not the cause, it shall promptly notify County and Covanta and other affected entities or individuals and take immediate steps to eliminate, terminate, abate or rectify the practice, procedure or condition. Contractor shall have general supervisory authority over its Work area, including the power and duty to correct safety and health violations or require their correction.

2.12.7 Contractor shall promptly investigate and compile reports on accidents involving personal injury and property damage. Copies of such reports shall be furnished to County and Covanta's Project Manager or his designee as soon as possible after each accident.

2.12.8 Failure of Contractor or any of its Subcontractors or any of its or their employees to fully observe and comply with this Article shall be cause for termination.

## 2.13 Contractor Personnel

2.13.1 The assignment by Contractor of qualified, experienced management, technical, supervisory personnel, and skilled labor is of critical importance to the successful accomplishment of the Project. Contractor warrants that it has the experience and capability, including sufficient competent technical, supervisory and other personnel, and shall continually furnish such personnel and expertise until performance is completed. Contractor employees shall be (i) trained, skilled, competent and qualified for the tasks for which they are hired; (ii) able to recognize the hazards associated with the work being performed; (iii) knowledgeable regarding procedures to control or minimize such

hazards; and (iv) instructed to abide by all County, Covanta and OSHA requirements and other requirements imposed by Applicable Laws. Whenever Contractor has reason to believe that an employee (including a Subcontractor's employee) lacks the skill or understanding to comply with such requirements, Contractor shall replace or retrain such employee so that all employees on the Site are proficient in all such requirements.

2.13.2 Contractor shall appoint as "Project Sponsor" a senior level corporate officer who shall have overall home office or headquarters responsibility for Contractor's performance and be responsible for corporate management appraisal and monitoring of progress and performance. Communications received by the Project Sponsor shall be deemed to have been received by Contractor.

2.13.3 Contractor shall appoint a Project Manager and a Construction Superintendent, the latter to be located on-Site. Communications received by either of them shall be deemed to have been received by Contractor. In order to ensure continuity, Contractor's Project Manager, Superintendent and other key personnel shall not without the prior approval of County, be temporarily or permanently reassigned or given supplementary work assignments which may interfere with their responsibilities under this Contract.

2.13.4 Contractor shall provide the services of labor relations and safety professionals with suitable qualifications and expertise.

2.13.5 Contractor shall appoint a testing coordinator knowledgeable in commissioning practices. This coordinator shall be available at the commencement of Exhibit L activities.

2.13.6 Contractor shall maintain discipline, harmony, good order and productivity of its personnel and staff. At the request of County or on its own initiative, Contractor shall remove or arrange the removal from the Site of any personnel who do not meet reasonable standards of experience, competency or comportment, or who otherwise are a detriment to the health and safety of the work place or the Project. Contractor shall ensure that such personnel remain uninvolved with any aspect of the Project.

#### 2.14 Contractor's Equipment and Tools

Contractor shall be responsible for loss or damage to all of its or its Subcontractors' equipment, materials, tools or other articles used, or held for use. Covanta and County shall have no responsibility or liability for such equipment and tools or other articles of Contractor or its Subcontractors, under any circumstances, be considered a bailee of Contractor's or sub-contractors' construction equipment or tools.

#### 2.15 Taxes and Contributions

2.15.1 Contractor shall pay when due all taxes, duties, and fees imposed under Applicable Law by reason of Contractor's performance including, but not limited to: excise, storage, consumption taxes; license and registration fees; income, profit, franchise, real and personal property taxes (but not taxes on the real or personal property of County, Covanta, the Project or Site); employment taxes and contributions imposed by Applicable Law or trade union contracts with respect to or measured by compensation (wages, salaries, benefits or other) paid to employees of Contractor, including but not limited to taxes and contributions for unemployment compensation insurance, retirement benefits, health and welfare funds, training, pensions and annuities, and disability funds and insurances. Contractor, at its cost, shall defend, indemnify and hold County, Covanta, and its Affiliate Companies from all liability resulting from Contractor's failure or the failure of its vendors or sub-contractors to make timely payment or comply with the reporting, filing or other procedural requirements under Applicable Law with respect to payments required hereunder. County shall reimburse the Contractor for Sales and Use taxes properly paid if it is agreed that such Sales and Use taxes are specifically excluded from the Contract Price. However, the Contract Price shall include the cost of any administrative work to pay, document, substantiate, reimburse or estimate any exemptions or taxes reimbursable hereunder.

2.15.2 In the event that the County has been or becomes exempted from any taxes otherwise payable, the Contractor shall be so instructed and an appropriate procedure for the handling and administration of such exemptions shall be developed and agreed by the Parties with the Contract amended as appropriate. If any of the material and equipment purchased by Contractor is eligible for exemption from any Sales and Use Tax, or an exemption from property or other relevant taxes exists as a matter of law, no such taxes shall be paid by Contractor without the prior written consent of County.

2.15.3 Contractor shall cooperate with County to secure and maintain any exemptions available to the Project or Existing Facility. In the event Contractor is assessed any taxes otherwise believed to be non-assessable, Contractor

shall promptly notify County of the particulars and shall cooperate with County should County elect to protest any such assessment.

2.16 Inspection of Site and Project

2.16.1 County or Covanta shall have the right at all times to conduct routine and normal inspection of all workmanship and Product furnished under this Contract and shall have access at all times to the Project. Contractor shall provide County or Covanta reasonable facilities and time for the purpose of inspection prior to covering. When finished Work is taken down or Product furnished under this Contract is disassembled or uncovered for the purpose of inspection, Contractor shall pay all costs incurred thereby if such workmanship, equipment or material is found to be defective. County shall pay all costs incurred thereby in the event such equipment or material is found to be in accordance with this Contract.

2.16.2 Inspection of Work shall also include Product during its manufacture and, if requested, Contractor shall arrange for County representatives to visit the factories or other places of fabrication and assembly.

2.16.3 At reasonable times, County or Covanta may inspect the appropriate records of Contractor and its Subcontractors to ascertain Contractor's and all other participants compliance with the safety and health requirements of this Contract or to confirm reported progress. However, neither the existence nor exercise of such right shall relieve Contractor of its responsibility for monitoring compliance with the safety and health requirements and for fulfilling all its other obligations.

END OF ARTICLE

## ARTICLE 3

### COMMENCEMENT, COMPLETION, TESTING, ACCEPTANCE AND DAMAGES

#### 3.1 Time and Order of Work; Earlier Completion

3.1.1 To promote overall general progress, Contractor's activities shall be planned, commenced, prosecuted and performed in a prompt, diligent manner, in sensible and agreed sequence or at such times and in such a manner that achieves the schedules for the completion of each of the various phases including checkout, testing and start-up. Equipment, construction aids, materials and labor to be furnished by Contractor shall be acquired and be available in sufficient time and quantity to enable Contractor to perform and complete the various phases within the planned times. Performance shall be without interruption and Contractor shall not reduce its resources without the approval of County.

3.1.2 If at any time in the reasonable opinion of County or Covanta, the Contractor's labor force, supervision or procurement shall be or become inadequate for achieving the necessary schedule, order, progress or quality, the Contractor shall, on notice from County or Covanta, or on its own initiative, and at its own expense, increase or supplement these items to the extent required to restore lost sequence or progress and assure compliance with the schedule milestones and required quality. Failure of County or Covanta to make specific demands hereunder shall not relieve Contractor from, or operate as a waiver of, its obligations to maintain the required sequence and rate of progress.

3.1.3 The Contractor shall be responsible at all times for the efficiency and adequacy of the means, methods of construction or performance, materials, work force and equipment, irrespective of whether it acts as a result of any direction of County or Covanta.

#### 3.2 Notice To Proceed

Contractor shall commence its activities promptly upon receipt of a formal Notice To Proceed and shall perform the same with diligence in accordance with sound and generally accepted engineering and construction practices until all of its obligations pursuant to this Contract, including timely Completion, guarantees and warranties have been fulfilled.

#### 3.3 Completion and Liquidated Damages

3.3.1 Timely performance is the essence of this Contract. Contractor shall complete the Work in accordance with the Schedule and this Article 3. Completion shall mean and shall occur when the Contractor's Work, including procurement, construction, installation, painting and lining, and check out of all mechanical, electrical, instrumentation and control systems have been turned over complete, calibrated, tested and operable, thereby allowing start-up and continuous normal operation and use of the Project as intended by the design. Completion shall be demonstrated by a safe and successful start-up. Any delay in performance not excused under this Contract will result in substantial loss to County, subjecting Contractor to damages.

3.3.2 Contractor shall achieve Completion as defined in this Article no later than the agreed and stated number of calendar days from Contractor's receipt of formal Notice to Proceed. Should Contractor be late, County will suffer considerable losses and be substantially damaged thereby, the extent to which Contractor's contribution will be difficult to quantify with any reasonable degree of precision, consequently, the Parties have agreed to quantify such damages in advance. Therefore, in the event Contractor fails to achieve Completion by July 6, 2006, Contractor agrees to pay County as liquidated damages (and not as a penalty nor subject to any proof of such loss) the sum of \$1,000 for each calendar day that Contractor is late. Such damages as are assessed may, at the option of County, be offset from any amounts (including retainage) that may be due Contractor or backcharged to Contractor.

#### 3.3.3 (Deleted)

3.3.4 Contractor recognizes the importance of not interfering, and shall not interfere, with the operation and maintenance of the Existing Facility during any phase of Contractor's Work. Should Contractor, or any of its Subcontractors or other parties in Contractor's control, cause the Existing Facility's processing capacity to be interrupted or limited, by accidentally tripping the Existing Facility or for any other reason, without prior coordination and written agreement from Covanta, County will suffer considerable losses and be substantially damaged thereby,

the extent to which Contractor's contribution will be difficult to quantify with any reasonable degree of precision, consequently, the Parties have agreed to quantify such damages in advance. Therefore, in the event Contractor causes the operating shutdown of either or both solid waste processing trains of the Existing Facility, Contractor agrees to pay County as liquidated damages (and not as a penalty nor subject to any proof of such loss) the sum of [ \$ later \_\_\_\_\_ ], for each occurrence that Contractor causes each processing train to shutdown, plus [ \$ later \_\_\_\_\_ ] for each hour each train is prevented from processing solid waste as a result of each such occurrence. Such damages as are assessed may, at the option of County, be offset from any amounts (including retainage) that may be due Contractor or backcharged to Contractor.

#### 3.4 Interim Checkout

As equipment, systems, subsystems or other major components of the Project are completed, County or Covanta shall be permitted (but not required) to commence its own checkout and testing of such individual components. Contractor deficiencies revealed during this interim checkout period will be promptly corrected and made good by Contractor at its expense.

#### 3.5 Phased Systems Turnover

Contractor agrees that to support an orderly phased start-up of the Project and avoid compression of such activity, Contractor agrees to turn over the various systems and subsystems of its Work in the order designated and sequenced by County or Covanta, or set forth in the Project Schedule and supporting CPM schedules, sufficiently in advance of the scheduled start-up activities. Contractor acknowledges that commissioning activities by County or Covanta may be carried on concurrently with ongoing Contractor activities provided they do not unduly interfere with Contractor.

#### 3.6 Certificate of Occupancy

Contractor acknowledges that codes, statutes, ordinances may require a temporary or permanent certificate of use or occupancy or other similar approval in order to use or occupy the Project. If Contractor's actions or lack of progress precludes timely receipt of any such certificates, resulting in delays in start-up, commissioning or operating activities, delay damages and the cost of corrective actions to obtain the necessary permissions shall be to Contractor's account.

#### 3.7 Acceptance of Work

Acceptance shall occur upon the fulfillment of all of the following conditions: (i) Completion and the other criteria specified in Article 3.3, have been satisfied and confirmed by initial performance testing of the Project, (ii) delivery of documentation in accordance with Article 2.7 and "As built" reproducible record drawings, final CADD work product, electronic data and instrument calibration records, document and drawing indexes, computer programs and access codes, control keys, non-destructive test and inspection records and reports, hydrostatic, air or other required test records, certified drawings, manuals, all warranties for Contractor-supplied equipment; (iii) Contractor's Affidavit of Payment, Waiver of Liens and General Release; (iv) receipt of a Certificate of use or Occupancy from the appropriate authority provided that any delay in the receipt is not dependent upon circumstances caused by or beyond the control of Contractor; (v) correction of all Contractor deficiencies which would preclude acceptance of the Project by the County or Covanta; (vi) receipt of any other documentation required by this Contract, (vii) general satisfactory compliance with the requirements of this Contract. Acceptance hereunder shall commence the warranty periods and the processing of final payment including retainage.

END OF ARTICLE

## ARTICLE 4

### CONTRACT PRICE

#### 4.1 Contract Price

As full and complete compensation for Contractor's performance, County shall pay Contractor a fixed lump sum Contract Price of \$87,000, payable in accordance with the Payment Provisions of the Exhibits.

The A36 carbon steel plate material portion of the Contract Price is \$12,000 and is subject to economic adjustment. All other costs are firm fixed prices and not subject to adjustment. The \$12,000 is comprised of 23,600 pounds of A36 carbon plate. Adjustment (increase or decrease) of the \$12,000 is subject to the price per pound of A36 carbon plate at the time Contractor purchases the material multiplied by 23,600 pounds. Contractor shall substantiate purchase price by submitting certified documents. The maximum increase of the \$12,000 price shall in no event exceed \$2,000. As a result of any change in final contract price a Change Order will be issued in accordance with this Contract.

#### 4.2 Progress Payments

Notwithstanding any schedule of payment, all payments to Contractor, including Change Order payments, shall reflect and be subject to progress and equipment in place.

#### 4.3 Invoicing

4.3.1 On a fixed date each month as shall be agreed, Contractor shall render its invoice with any required supporting documentation. This invoice shall constitute Contractor's certification as to progress, related amount, that all indebtedness incurred in connection with the Work to date has been or, in due course, will be paid on a timely basis and that to Contractor's knowledge and belief, there exist no claims, liens or other encumbrances with respect thereto. County shall review the invoice and the supporting documentation for contractual compliance, progress and accuracy, advise Contractor of any amount which it disapproves with the reasons therefor, adjust the funding, if necessary, for any under or overpayment and remit the approved amount of the invoice to Contractor. Payments shall not constitute acceptance or approval for any Work not properly performed or costs not properly incurred. County shall not pay for incomplete or defective Work.

4.3.2 In order to secure benefits that may be available to County under federal, state and local revenue codes, including state and local sales and use tax laws and regulations, or under any other public law, Contractor agrees to provide, if required, limited disclosure of costs for specified categories of services, labor, equipment, systems or materials. Any disclosure shall be minimized and limited so as to preserve as much as possible the fixed price nature of the Contract.

#### 4.4 Retainage

In order to ensure compliance with this Contract, five percent (5%) of each payment shall be retained by County. This retainage will be remitted to Contractor promptly upon the satisfactory discharge of Contractor's obligations as set forth in Article 4.6.

#### 4.5 Retainage for Punch List Items

Covanta and Contractor shall agree on the items requiring completion or correction by Contractor in order for Contractor to fully complete the Work and the cost of correcting or completing of each item. County shall be entitled to withhold a sum equal to twice the aggregate value of the items on the list. As Contractor corrects or satisfactorily completes an item, County shall pay to Contractor the value withheld corresponding to the item corrected or completed. In the event the amounts due Contractor are insufficient for this purpose, Contractor shall deposit with County an amount sufficient to make the sum to be held under this paragraph equal to twice the aggregate value of the items.

#### 4.6 Final Payment

Upon Completion, including the receipt of all of the deliverables required by this Contract and County's Acceptance in accordance with Article 3, and after all adjustments and unsettled matters (including any liens or charges) have been disposed of, Contractor shall submit its final invoice for the unpaid balance of the Contract Price including Change Orders and retainages. Contractor's final invoice shall be accompanied by: (i) Proof by affidavit satisfactory to County that there are no unsatisfied or uninsured claims or judgments for injuries to persons or damage to property and that



no other indebtedness for which Contractor is responsible exists which is or may become, in the judgment of County, a detriment to County or a charge or an encumbrance on the Existing Facility or the Project or its premises; (ii) documents, statements of account, affidavits or other assurances which County may reasonably require to insure immunity from liens, claims, or charges against County, Covanta, Existing Facility or the Project or the funding thereof arising out of Contractor's performance for which County, or Covanta may become liable; (iii) general releases to County, and Covanta from Contractor, acting for itself, its Subcontractors and suppliers, discharging County, County's representatives, including Covanta and its Affiliate Companies, and the officers, directors, officials and employees of each from all liabilities, obligations and claims arising out of Contractor's performance of this Contract other than matters which Contractor is or in good faith is contesting or intends to contest against third parties. Provided the criteria set forth above are reasonably met, County shall pay Contractor the unpaid balance of the Contract Price including retainage.

#### 4.7 Representation

Contractor represents that all documents including invoices, billings, waivers, certifications, releases, reports or other representations made or submitted by Contractor shall, to the best of Contractor's knowledge and belief, be complete and accurate, truly reflect the facts about the activities and transactions to which they pertain and contain no material misstatements or omissions and hold County and Covanta harmless from any material breach of such representations. Contractor understands that County and Covanta will have the right to and shall rely on those documents and reports as such. Contractor will place similar requirements upon its contractors and vendors. Acceptance of such reports and documents shall not constitute the agreement of County or Covanta with their contents.

#### 4.8 Liens

Contractor shall promptly pay all indebtedness incurred in Contractor's performance. Contractor shall not have and hereby agrees to waive for itself and to the extent not proscribed by law, cause its contractors, suppliers and materialmen to waive any right to place a mechanics or materialmen's lien, trust (including the creation of a Lien Law Trust) or similar charge or encumbrance on the Existing Facility, the Project, the Project or Existing Facility premises or the Project funding, whether or not such liens, charges or encumbrances are founded upon common, local, state or national law. If such a lien or charge or any form of trust attaches or is created by any reason of failure by Contractor, its contractors or vendors to pay such indebtedness, or otherwise, Contractor shall promptly procure its release by bond, by payment or otherwise and shall hold County and Covanta harmless from any loss, damage and expense incidental thereto. If County reasonably believes a lien, charge or claim for which County might be or become liable or to which County's or Covanta's property might be or become subject and which is chargeable to Contractor, its contractors or vendors, County may retain out of any amounts due to Contractor an amount which in the judgment of County is reasonably sufficient to protect against such lien, claim or charge including attorney's fees and associated costs. County will retain said amounts until Contractor pays and discharges the lien, claim or charge or until County is satisfied that such lien, claim or charge is invalid. In that event County will promptly release the amount retained and remit the same to Contractor less any costs County is entitled to assess Contractor. If in County's judgment, such lien or claim is valid, County may pay and discharge the same and deduct the amount paid from the balance of the Contract Price due Contractor. If such a lien, claim charge, trust or other encumbrance remains unsatisfied after Completion and Acceptance of the Work, Contractor shall promptly refund to County all amounts paid by County in settling and discharging the same including the costs and reasonable attorneys' fees. Florida's Public Construction Statute, Section 255.05, Florida Statutes, is applicable to this Project. Contractor acknowledges that no lien rights are available against the public property and that no Notices to Owner shall be furnished to the County nor shall any liens be recorded against County's interest in the real property.

END OF ARTICLE

## ARTICLE 5

### GUARANTEES AND WARRANTIES

#### 5.1 General Warranty

5.1.1 Contractor warrants that its performance shall in all aspects be in accordance with established industry codes and recognized professional standards; with the customary accuracy, care and skill expected of firms in the industrial construction business; shall comply with all applicable laws and regulations; shall conform to the requirements of this Contract; not violate any patent, copyright, or other proprietary interest; that workmanship, equipment and materials will be new, of the highest quality; and remain free from defects for a period of twenty four (24) months (or longer for components identified in the Exhibits as having extended warranties from Contractor's vendors such as roof, panels, siding, coatings, HVAC systems) from completion of the Work or (12) months of operation, whichever occurs first. . County and Covanta shall be beneficiaries of the warranties herein.

5.1.2 During the warranty period, Contractor shall at its cost and expense, including the cost of removal, transport, re-installation and testing, promptly correct, repair or replace any defective workmanship, equipment and materials upon being given notice thereof. The warranty period for the repair and/or replacement shall be twelve (12) months from the making good of any deficiency or the remaining balance of the twenty four (24) months required in Article 5.1.1, whichever is longer. In the case of defects in components with extended warranties, the one year shall be additive to the remaining extended component warranty period identified in the Exhibits. If Contractor fails to make good the deficiency in a timely manner, County, at its option, may correct the deficiency with the cost charged to the Contractor and deducted from any amounts due or which thereafter become due. If no amounts are or become due, the difference shall be paid to County by Contractor plus any and all other damages to which County may be entitled as a result of such deficiency and Contractor's failure to make the corrections.

#### 5.2 Latent Defects

If any defect of the kind referred to in Article 5.1 above shall appear in any part of the Contractor's equipment, material or workmanship within a period of forty eight (48) months after the date of Acceptance, the same shall be made good by the Contractor by repair or replacement at Contractor's expense if the defect would not have been disclosed by a reasonable examination prior to the expiration of the warranty period .

#### 5.3 Equipment and Materials Warranty

Contractor directly warrants any workmanship, equipment and materials purchased and supplied by or through Contractor. Suitable warranties and guarantees shall be obtained by Contractor from its contractors and vendors which shall be unconditionally assignable to County or its designees upon request. County and Covanta shall be third party beneficiaries of all vendor and Subcontractor warranties.

#### 5.4 Performance Guarantees, Testing and Damages

Contractor shall be responsible for the fulfillment of the Performance Guarantees provided in the Exhibits.

END OF ARTICLE

## ARTICLE 6

### INDEMNIFICATION, BONDS AND INSURANCES

#### 6.1 Indemnification

To the fullest extent permitted by Applicable Law, Contractor agrees to protect, defend, indemnify and hold County and Covanta, its parent and Affiliate Companies, and their respective agents, successors, or assigns, including the officers, directors, officials and employees of the indemnitees, completely free and harmless from and against all allegations, liabilities, actions, damages, claims, demands, judgments, losses, costs, expenses, attorney's fee, suits, or actions, appeals, including liability for personal injury or death to any parties including Contractor's employees, or loss of or damage to property, arising directly or indirectly, actively or passively out of the performance or nonperformance of this Contract, including the negligence, willful misconduct, bad faith or lack of due diligence of Contractor, its agents, Subcontractors, or employees. This obligation shall apply irrespective of whether there is a breach of a statutory obligation or any rule of apportioned liability except to the extent that such indemnification is precluded by Applicable Law. Indemnitee shall promptly notify Contractor of any claim for which indemnification is sought hereunder, give or afford Contractor opportunity to defend and shall not settle such claims without the approval of Contractor, which approval shall not be unreasonably withheld. Only in situations where the claimant alleges fault on the part of Contractor and another person indemnified under this paragraph, Contractor's obligation to fully indemnify and defend County and the other indemnitees referenced herein shall be limited to a maximum liability of twenty-five million dollars (\$25,000,000.00). This limitation on indemnification is incorporated by reference into the Project Exhibits and all other Contract documents applicable to this Contract.

#### 6.2 Labor/Material and Performance Completion Bond

As a condition precedent, Contractor shall provide, substantially in the form attached as an Exhibit from a surety acceptable to County a Labor/Material Payment and Performance Completion Bond in an amount not less than the Contract Price for the benefit of County, Covanta and such other obligees as County may designate. Such Bond shall be and provide that it is unconditionally assignable to Covanta. The surety shall be licensed in the state or other jurisdiction where the Project is located and be currently listed in the U.S. Treasury Department's list of "Surety Companies Acceptable on Federal Bonds", A. M. Best Company, or as otherwise approved by County. This Bond shall be issued and delivered to County on or prior to the signature of the Contract by Contractor. Contractor's Performance Completion Bond shall expressly state that it covers the obligation of the Contractor to pay delay damages to County in the event such damages become due and owing under the terms of the Contract. Except for surety bond(s) provided under Article 4.8, LIENS, the premium on a Labor/Material Payment and Performance Completion Bond shall be stated separately in the proposal and shall be paid for by the County.

#### 6.3 Insurances

Prior to commencing its services, Contractor, solely at its expense and irrespective of the manner or of the establishment of the premium costs, shall provide and maintain in effect the following types and amounts of insurance written on an occurrence basis with insurance companies licensed in the state or other jurisdiction in which the Project is located and rated A by A. M. Best Company. This coverage shall remain in effect for a period of thirty-six (36) months from Completion. Deductibles shall be permitted only with the consent of County. All premiums and costs associated with insurances required by this Contract no matter when, how or by whom determined including any increase in worker's compensation rates are for the Contractor's account and included in the Contract Price. Wherever the term County is used in this Article 6.3 et seq., it shall be deemed to include Covanta and its Affiliate Companies.

##### 6.3.1 Workers' Compensation Insurance

Workers' Compensation Insurance required by Applicable Law covering all Contractor employees and with no deductible amount.

##### 6.3.2 Employer's Liability Insurance

Employer's Liability Insurance with limits of \$1,000,000 per occurrence, accident or disease, with no deductible amount.

##### 6.3.3 Comprehensive General Liability Insurance

Comprehensive General Liability and Property Damage Insurance, with Contractual Liability, Products/Completed Operations, Personal Injury, Disease, Fire Damage, Legal Liability and Broad Form Property Damage liability coverages, with primary limits of liability of at least \$1,000,000 per occurrence, or amounts sufficient to support the purchase and maintenance by Contractor of excess liability insurance coverage in an amount of \$ 9,000,000 with County and Covanta as Additional Insureds.

#### 6.3.4 Comprehensive Automobile Liability Coverage

Comprehensive Automobile Liability Insurance with a combined limit per occurrence for bodily injury and property damage of at least \$1,000,000 per occurrence or amounts sufficient to support the required excess insurance coverage, with County and Covanta as Additional Insureds.

#### 6.3.5 Excess Liability Coverage

Excess Liability Insurance in form following primary insurances in the amount of \$9,000,000 per occurrence in excess of 6.3.2, 6.3.3 and 6.3.4, with County and Covanta as Additional Insureds.

#### 6.3.6 Builders "All Risk"

Builders All Risk Insurance shall be provided for the Project by County or Covanta. This insurance shall be to the full insurable value of the Project and shall include "advance loss of profits." Covanta, County, Contractor and its Subcontractors shall be insured, as their interests shall appear. The policy shall contain a deductible of which the first \$25,000 of each loss shall be for the account of the Contractor or its Subcontractors. This policy shall not cover Contractor's equipment, which is the responsibility of the Contractor.

#### 6.3.7 Waiver of Subrogation/Recourse

All Policies shall be endorsed to provide that underwriters and insurance companies of Contractor shall not have any right of subrogation or recourse against County and any Additional Insureds. Coverage shall be primary to any coverages maintained by or on behalf of County or Covanta and shall contain a severability of interest clause and cross liability endorsement. To the extent that compensation for any injury, loss or damage shall have been recoverable under any Contractor insurance policy, Contractor waives any claim for recovery from County or Covanta for such loss or damage arising out of the performance of this Contract.

#### 6.3.8 Certificates

Before commencing Work on the Project, Contractor shall furnish acceptable certificates evidencing that the insurance required hereunder is in place, and, if requested, shall make available the actual policies for County or Covanta inspection. Each certificate shall list the Additional Insureds and shall provide that sixty (60) days prior written notice be given County and Covanta in the event of expiration, cancellation or other material change in the policies. Renewal certificates should be submitted at least thirty (30) days prior to the expiration of any insurance.

#### 6.3.9 Subcontractors

Contractor shall require its Subcontractors to obtain, maintain and keep in force, similar insurance coverages with limits appropriate to their risks and scope of Work. If requested by County, Contractor shall furnish County acceptable evidence of such insurance before the Subcontractor commences its Work.

#### 6.3.10 Insurance in Force

Contractor and its Subcontractors shall not commence the shipment of materials, equipment or tools to or commence activity at the Site until all of the insurance that Contractor is required to provide is in force and the necessary certificates issued and delivered to County.

END OF ARTICLE

## ARTICLE 7

### CHANGES

#### 7.1 Discretionary Rights of County

Subject to Contractor's rights under Article 7.2 below, County shall have the right at any time without the consent of Contractor to revise any elements of the Project (including elements already completed or being performed), add to or omit a part of the Work or Project previously authorized, make final decisions on interpretation of the Design, and designate or reject Contractor sources of supply.

#### 7.2 Change Orders

7.2.1 County shall issue a Change Order only when elements of the Work are materially revised or when County requires additional work and services clearly beyond the Contractor's original scope, directs an omission or reduction in the Work or exercises any other such discretionary rights under Article 7.1 above.

7.2.2 If Contractor believes that a request, instruction, direction, action, interpretation or decision of County or Covanta meets the criteria for a Change Order, Contractor shall notify County and Covanta within (7) days from receipt of the request, instruction, direction, action, interpretation or decision, and within (14) fourteen days of such initial notification, submit a Change Order Request with information reasonably sufficient to enable County to make proper evaluation. The Change Order Request shall be accompanied by a detailed description of the circumstances, the specific reason for the change, a reasonably detailed work itemization and substantiation of any requested adjustment in Contract Price and/or Schedule. Contractor shall also furnish any documentation, charts, graphs, photographs and reports which bear on the change, specific references to the provisions of this Contract on which the Contractor intends to rely, and any other supporting data and information which County might reasonably require. If Contractor's costs are materially and demonstrably affected, Contractor shall prepare and furnish an estimate of the effects of the change on the Contract Price and/or Schedule. To the extent the Parties agree, County shall issue a Change Order. The Change Order shall be deemed inclusive of all costs, effects and impacts whether direct or indirect, including credits to County for reduced Work scope or increases in Contract Price for additions to the Work. Contractor's administrative costs in preparing any Change Order Request shall not be allowed.

#### 7.3 Pricing

7.3.1 Wherever possible or practicable, a Change Order shall be fixed price. However, if this is not practical because of timing, economics or other constraints, the Change Order may be priced on a Time and Material, or such other basis as shall be agreed. Rates for Time and Material Work shall be set forth in the Exhibits and shall include all Contractor costs, charges, expenses, overheads and profit.

7.3.2 For Work performed on a Time and Material, basis, Contractor shall support each invoice with evidence of actual costs and expenditures including personnel time sheets, bills, invoices, receipts, bills of material, receiving documents or such other appropriate documentation. Contractor shall maintain accurate and detailed accounts for all such costs and shall permit County's and/or Covanta's auditors access to such accounts, books and records for audit purposes at reasonable times.

#### 7.4 Payment

Change Orders shall adjust the Contract Price, be invoiced as part of the regular payment procedure, but itemized separately for record keeping purposes and subject to progress payment requirements of this Contract.

#### 7.5 Change Orders Not Allowed

No Change Orders will be allowed for any claims of incomplete Design, revisions by Contractor required to fulfill the Design, revisions necessary for Contractor to achieve compliance with this Contract or to correct errors, omissions in its workmanship, equipment and materials information and cost estimates reasonably required by County to assure optimum operability; any claims of Contractor that the cost of materials, labor, services or time for performance have increased since Contractor estimated and settled its Contract Price or Schedule; overtime premiums or bonuses paid by Contractor for labor, or for earlier delivery of equipment or materials (except where such action was taken at County's specific request and such request did not result from the Contractor's having fallen behind the Schedule); technical reviews; directions and actions of County already consistent with the requirements of this Contract; or Contractor's failure generally to comply with the requirements of this Contract.

7.6 Duty to Continue Work

In the interest of the communities the Project is intended to serve, delays and disruptions must be kept to a minimum. Contractor shall comply promptly with instructions, authorizations, directions and notices given by County, notwithstanding that a Change Order may not have been issued or that agreement may not have been reached on the effects, if any, on Contract Price or Schedule. Although it is the intent of the Parties to agree as to whether a Change Order is in order and to settle its terms whenever reasonable in advance of the particular work or Work to be performed, failure to agree on a change or the terms thereof or to any adjustment in the Contract Price or Schedule shall be treated as a dispute in accordance with Article 11.5, but shall not excuse Contractor from proceeding with performance as requested. County also reserves the right to contract with a third party to perform disputed work or Work in the event an agreement is not reached with Contractor on the terms of the change.

END OF ARTICLE

## ARTICLE 8

### TERMINATION AND SUSPENSION

#### 8.1 County Right to Terminate

County may at its sole convenience at any time and for any reason cease all or any part of the Work or Project and terminate Contractor's services with five (5) days Notice to Contractor specifying the portion terminated and the effective date. Contractor shall cease performing that part of the Work terminated but continue to perform unterminated part.

#### 8.2 Termination for Default

8.2.1 If Contractor defaults in the performance of any material provision of this Contract, including without limitation failure to supply sufficient qualified personnel or Product, or to perform with diligence, or to make payments to its contractors, vendors or other suppliers of services or Product to the extent the same are due and owing; disregards Applicable Law; fails of its ability to achieve the progress or Completion; becomes insolvent or makes any assignment for the benefit of Contractor's creditors (including payments due under this contract) or in any way becomes subject to a petition in bankruptcy or to appointment of a trustee or receiver, County may give Contractor Notice of Default.

8.2.2 If the default is not cured or corrective action is not commenced within five (5) days of receipt of Notice, then County shall have immediate and complete title to all Product delivered and undelivered to County and shall be entitled to take possession of the Site, the Product and all of Contractor's equipment, materials, supplies and construction tools and equipment and complete the Work as it deems expedient. Contractor's surety shall be put on notice of County's rights to claim and recover under the terms of the payment and performance completion bonds.

8.2.3 Contractor shall not be entitled to any further payment until the Project is completed. The total cost of completion shall be charged to Contractor and may be deducted from any amounts due or which may thereafter become due to Contractor. If the amount due Contractor is insufficient to complete the Work, Contractor shall pay to County the difference and all actual and consequential damages. This remedy is not exclusive, but is in addition to any and all other rights, remedies and damages to which in the event of Contractor's default, County may be entitled to in contract, equity or by operation of law. Contractor shall remain responsible and liable for the cost of making good any warranty or guaranty items during the period such warranties would have been in effect had Contractor not defaulted.

#### 8.3 Termination for Convenience

In the event the Work or part thereof is terminated at the convenience of County pursuant to Section 8.1 after the Notice to Proceed is issued, County shall pay Contractor subject to agreement as to amount, that pro rata portion (including reasonable profit) of the Contract Price which represents the amount of the Work satisfactorily performed, the Product put in place, materials and equipment procured prior to the effective date of termination plus Contractor's unavoidable vendor cancellation charges resulting directly from termination hereunder. County shall not be liable for any other sums to Contractor as a result of termination hereunder, including the loss of any expected or anticipated revenues or profits, under-utilization of personnel, equipment or manufacturing facilities, similar items of consequential loss or damages, or any other categories of costs, damages or claims.

#### 8.4 Action Upon Termination

Upon the receipt of Notice of Termination, Contractor shall cease all activity, secure the Site, place no new orders for Product or services, provide a schedule or listing of all vendor orders or commitments and, unless otherwise directed, cancel all orders placed or commitments made. Contractor shall, if requested, assign subcontracts and purchase orders to County, execute and deliver to County all documents and other deliverable items and take all other necessary steps to vest in County the rights and benefits of Contractor under such existing agreements, including the certifications of a professional engineer.

8.5 County Right to Suspend

County may suspend any part of the Work at any time and for any reason upon twenty-four (24) hours Notice to Contractor specifying the part to be suspended and the effective date. Contractor shall cease performance on the suspended portion, but shall continue to perform any unsuspended portion. For the portion suspended, only the cost of those items authorized in advance by County shall be allowed during the period of suspension for which a Change Order will be issued. County may, at any time, authorize resumption of the suspended Work on Notice to Contractor and Work shall be promptly resumed by Contractor after receipt of such Notice. If said suspension has been in effect for at least one hundred twenty (120) days and provided such suspension has not occurred in whole or in part because of defects or deficiencies or any material breach of this Contract by Contractor, Contractor may notice County of its intention to terminate the suspended Work. If County does not authorize a resumption within ten (10) days of Contractor's notice, Contractor may terminate the suspended Work. For purpose of compensation, termination hereunder shall be deemed a termination for County's convenience pursuant to Section 8.1. County shall not be liable for any damages or loss of expected revenue or profits of Contractor, due to under-utilization of personnel, equipment or manufacturing facilities or similar items of consequential loss or damages as a result of any suspension.

END OF ARTICLE



## ARTICLE 9

### COUNTY RESPONSIBILITIES

#### 9.1 General Specification

County shall provide Contractor with the Design, including drawings, plans and specifications as well as the other appropriate documents and information necessary to Contractor's performance.

#### 9.2 Site

County shall provide the Site including suitable access, ingress and egress. Parking for staff and work force, and storage shall be arranged and provided by Contractor, unless otherwise agreed with County and Covanta.

#### 9.3 Permits; Licenses; Approvals

County shall obtain and make available planning, zoning, environmental and similar permits and other necessary official approvals for the Project, excepting those licenses, registrations and permits specifically required to be provided by Contractor under this Contract or necessary to enable it to perform and to carry on its business as a Contractor in the jurisdiction of the Site. County shall provide information, as is available and may be necessary, to assist Contractor in obtaining all permits and licenses required to be obtained by Contractor under this Contract and by Applicable Law. Contractor shall provide reasonable technical support and other assistance to the County permit approval process as may be requested or support in the issuance of a Notice to Proceed.

#### 9.4 Project Manager

County shall appoint a Project Manager (or other authorized representative) who shall have the sole authority to act for County with respect to this Contract, all matters pertaining to the Project and Contractor's performance. Communications in the normal course of Project implementation received by him shall be deemed to have been received by County subject to Article 11.11 respecting formal Notices required under the Contract. County may also appoint a Resident Construction Manager who shall be delegated authority by the Project Manager to act with respect to day to day on-Site technical and commercial matters.

END OF ARTICLE

## ARTICLE 10

### CONFIDENTIALITY AND NONDISCLOSURE

#### 10.1 Confidential Information

10.1.1 As used herein, Confidential Information means information now or hereafter owned by, or otherwise within the possession or control of County or Covanta including, without limitation, patented and unpatented inventions, business and trade secrets, know-how, techniques, data, specifications, as-built drawings, blueprints, flow sheets, designs, engineering information, construction information, operation criteria and other tangible and intangible information related to the purposes of this Contract. County or Covanta has or will disclose to Contractor Confidential Information of County or Covanta, its parents, subsidiaries, Affiliate Companies and others in order for Contractor to perform the Work. All drawings, specifications, blueprints, calculations, data, reports and other documents, as well as information, improvements in connection with the Project and documents developed by Contractor or supplied to Contractor by County or Covanta, all whether manifest as writings or computer programs or codes, shall be deemed Confidential Information.

10.1.2 Contractor agrees that it will not use the Confidential Information for any purpose other than the accomplishment of the Project, and that except for employees or contractors of Contractor described below, Contractor will not any time without the prior written consent of County and Covanta, publish, disclose or otherwise disseminate, duplicate or use, directly or indirectly, Confidential Information to or for the benefit of any third party whether or not it relates to a process, product, equipment or apparatus embodied therein. Any third party request to pursue records pursuant to Chapter 119, Florida Statutes shall be immediately forwarded to the County with a copy to Covanta.

10.1.3 The foregoing shall not apply to knowledge or information which (i) at the time of disclosure is already in the public domain or public knowledge; (ii) after disclosure, becomes part of the public domain or public knowledge by publication or otherwise, except by breach of this Contract by Contractor; (iii) Contractor can establish by competent written proof was in its possession at the time of disclosure by County or Covanta and was not acquired, directly or indirectly, from County or Covanta, (iv) is required by a validly issued subpoena, warrant or court order provided the Contractor shall have so notified County and Covanta and shall have refrained from making such disclosure to the fullest extent permitted to afford County or Covanta a period of time within which County or Covanta may challenge such subpoena, warrant or court order in the appropriate forum.

#### 10.2 Subcontractors, Vendors and Employees of Contractor

Contractor shall disclose Confidential Information only to those contractors, suppliers and employees of Contractor directly involved in the Project on a need to know basis. Contractor shall advise each such contractor, vendor and employee that he, she or it will be strictly bound by the terms, conditions and intent of this Article and that a violation will constitute a material breach of this Contract by Contractor. County or Covanta may, in certain instances, require that such parties or persons furnish County and Covanta a statement that they have read this provision and agree to abide strictly with its terms.

#### 10.3 Inventions and Improvements

Should Contractor or any employee, representative, vendor or contractor of Contractor assigned to or involved in the Project make any inventions or improvements to or connected with the Project, the same shall become the sole and exclusive property of Covanta. Contractor agrees to notify County and to execute or cause to be executed any and all patent applications, assignments or other documents required to vest and retain in County, or its assignee, title to any and all such inventions or improvements. County shall pay the reasonable out-of-pocket expenses of Contractor in connection therewith.

#### 10.4 Ownership and Disposition

No right or license is granted respecting the use of Confidential Information. Title thereto and all intellectual property rights therein shall be in County or, as applicable Covanta, at all times. Upon Completion, Contractor shall promptly deliver to Covanta all copies of the Confidential Information which are in its possession or under its control including all drawings, specifications, blueprints, reports and other documents which have been prepared or developed by Contractor for the Project or which are supplied to Contractor by County or Covanta. If County does not issue a Notice To Proceed or terminates the Work of Contractor, all copies of Confidential Information shall be destroyed or be returned to County forthwith as may be directed by County. Contractor, its Subcontractors and vendors, and their respective employees and agents shall cooperate with County to establish such right and title and shall, at County's

expense, assign all rights they may have with respect thereto to County, or assignee, and execute such documents as County may request to effect such purpose. To the extent that copies of Confidential Information are authorized in writing by County and Covanta to be retained by the Contractor, such copies shall be retained subject to the confidentiality requirements of this Article. The Contractor shall label and identify all Confidential Information as such and take all necessary precautions to protect Confidential Information from intentional or accidental disclosure.

#### 10.5 Publicity

Contractor shall not advertise, issue brochures or make any announcement or release or publish any information for promotional, informational or any other purpose concerning the content of this Contract, the Confidential Information, the Existing Facility, the Project or the services performed by Contractor hereunder to any third parties, including the public, the press or any official body without the express written permission of County and Covanta management personnel authorized to grant such permission. Contractor acknowledges that the trade and service names, marks, and logos of Covanta, and all Affiliate Companies are of great value and agrees not to use or permit their use (or misuse) in any manner that would impair the rights or image of Covanta or the County.

#### 10.6 Remedies for Breach

Contractor agrees that any breach of this Article is material and shall entitle County or Covanta to obtain from any court of proper jurisdiction injunctive relief including an accounting for all profits or benefits arising out of such breach in addition to any other legal remedies (including termination of this Contract for breach) and damages to which County may be entitled.

#### 10.7 Duration of Obligations

The obligations of Contractor under this Article shall survive the ending or termination of this Contract and shall continue for a period of ten (10) years from Acceptance or termination of the Contract.

END OF ARTICLE

## ARTICLE 11

### GENERAL PROVISIONS AND COVENANTS

#### 11.1 Compliance With Applicable Law: Postings

11.1.1 Contractor shall be aware, observe and abide by all Applicable Laws. Contractor agrees to defend, indemnify and hold County and Covanta harmless (including expenses and legal fees) from any liability or penalty which may be imposed by reason of Contractor's failure or alleged failure to observe and abide thereby.

#### 11.1.2 [reserved]

11.1.3 To the extent applicable to Contractor, Contractor acknowledges that the export of commodities or technical data from the United States and/or the re-export of commodities or technical data of U.S. origin, may be conditioned upon the issuance of an export license by the Government of the United States of America. Contractor represents and warrants that it will not export or re-export any commodities or technical data in furtherance of this Agreement unless and until it has complied in all respects with applicable U.S. export control regulations.

#### 11.2 Business Standards

In the performance of its obligations under this Contract, Contractor shall establish and maintain appropriate business standards, procedures and controls designed to prevent any real or apparent improper, unethical, criminal or other behavior which could adversely impact the interests of County, Covanta and its Affiliate Companies. If requested, Contractor shall review with County such business standards and procedures including, without limitation, those related to the activities of Contractor's employees and agents in their transactions and relations with County's and Covanta's employees, agents and representatives, vendors, Subcontractors, governmental authorities, and other third parties.

#### 11.3 Title

Title to the project and all Product or portions thereof shall pass to County or its designee upon delivery to County, or upon payment, whichever event first occurs. Contractor warrants that all Product furnished by Contractor is and shall remain free from any defects in such title including liens, claims, security interests and encumbrances of any kind. Contractor shall defend such title against a claim by any party and shall indemnify and hold County and Covanta completely harmless from and against any and all loss, costs, damage expense and other liability of any nature arising out of or otherwise resulting from any failure to comply with this warranty. As partial security for the performance of its obligations under this Contract, Contractor hereby grants to County a security interest in and to the Work and Product prior to the interests of any other party until passage of title. Upon request Contractor shall execute the necessary documentation and provide necessary assistance to County in order to permit County to perfect the security interest. It is expressly understood and agreed, however, that (i) the establishment of the security interest shall not release Contractor from its responsibility to fully carry out its obligations under this Contract and (ii) notwithstanding the passage of title, Contractor shall retain full care custody and control and all risk of loss until Acceptance.

#### 11.4 Force Majeure

11.4.1 Delay in or failure to carry out the duties imposed upon Contractor under the Contract shall not be deemed breaches of the Contract if such delay or failure is caused by the following Force Majeure events and by no others: fire, explosion, casualty or accidents, epidemic, cyclone, flood, drought, natural disaster, war, civil commotion, acts of public enemies, blockade or embargo, provided none of the foregoing events were caused by or through the acts, errors, negligence or carelessness of Contractor. Transport difficulties, labor, equipment or materials shortages, lack of productivity, strikes or other labor disputes of any kind (except a national strike) shall not constitute a basis for an event of Force Majeure. Contractor shall give prompt Notice thereof to County and Covanta, and shall attempt to remedy with all reasonable dispatch the cause or causes constituting the Force Majeure, keeping County reasonably informed.

11.4.2 If Contractor was delayed in Completion exclusively by reason of a Force Majeure event for which it is relieved of delay liability hereunder, the date for Completion shall be extended to the extent necessary to

compensate for the delay directly resulting from the event. However, no such extension shall (i) exceed the total delay encountered taking into account Contractor's use of best efforts to mitigate the effects of an event and ability to reschedule activities to minimize or eliminate delays in the Completion notwithstanding delays to certain portions of the Work or (ii) be granted unless written notice of such event is given to County as provided above, and (iii) be granted unless a claim for such extension is presented in writing to County within ten (10) days after the termination of such event. The foregoing shall be Contractor's sole remedy for an event of Force Majeure.

#### 11.5 Disputes and Claims

The Parties shall cooperate to facilitate the efficient and timely performance of the Project. The Parties further agree to undertake in good faith the resolution of disputes, if any, in an equitable and timely manner so as to avoid where feasible the need for legal claims or court actions of any kind. In the interest of the Project and the communities it is intended to serve, Contractor shall continue uninterrupted its performance pending the resolution of any dispute. In any dispute arising out of or relating to this Contract, the prevailing party shall be entitled to an award of its costs and reasonable attorneys' fees, including all such costs and fees incurred on appeal.

#### 11.6 Infringement of Proprietary Rights

Contractor represents and warrants that technology, equipment, apparatus, methods, engineering, designs and services provided by Contractor do not, in whole or in part, infringe the patent or proprietary rights of any party. In the event of an infringement or claim thereof, Contractor shall (i) protect, defend, indemnify and hold County and Covanta completely harmless therefrom and shall pay any liability, attorney's fees or costs in connection therewith; and (ii) at Contractor's cost and expense, promptly remove the source of the claim of infringement and procure the right to continue the use of such infringing (or allegedly infringing) item or method, technology or equipment including the payment of any royalties or other fees required, all at no cost to County or Covanta.

#### 11.7 Firearms, Drugs and Alcohol

The use or possession of firearms (or other similar dangerous devices), unlawful drugs or other controlled substances or the possession or consumption of alcoholic beverages on the Project or Existing Facility premises is expressly prohibited. It shall be the duty of Contractor to strictly enforce this prohibition, including the removal of offenders.

#### 11.8 Assignment

11.8.1 This Contract shall not be assigned by Contractor without the prior written consent of County and any such attempted assignment shall be void from the beginning. If an assignment is consented to, Contractor shall not be relieved of its obligations hereunder until they have been irrevocably and unconditionally assumed by the assignee.

11.8.2 There shall be no restriction on County's right to assign this Contract (or any portion thereof) except that such assignee shall have agreed to assume County's obligations hereunder. Upon notice to Contractor, County may, at its sole option, assign, transfer and convey all of its rights, obligations, title and interests (or any portion thereof), without Contractor's consent, to and under this Contract to a third party engaged by the County to construct the Project or erect the equipment. In the event the County elects to make such assignment, Contractor shall, to the extent reasonably required, cooperate with said third party in all respects to ensure efficient and cost effective erection and execute an Assignment and Assumption Agreement reflecting the above mentioned assignment and transfer of rights, obligations, title and interests. The Agreement shall be binding on the Parties and their respective successors and assigns.

#### 11.9 Relationship of the Parties

Contractor at all times shall be an independent contractor. County shall have no responsibility whatsoever with respect to obligations assumed by Contractor and nothing in this Contract shall be deemed to constitute County a partner, agent or legal representative of Contractor or to create any fiduciary relationship.

#### 11.10 Nondiscrimination in Employment/ Affirmative Action

11.10.1 Contractor shall comply with the County's Disadvantaged Minority and Women Business Enterprise ("DM/DWBE") Participation Contract Specifications attached hereto as Exhibit K.

11.10.2 Contractor shall not discriminate against any applicant for employment because of age, race, creed, color, disability, marital status, sex, national origin, ancestry, sexual orientation and arrest record. Contractor shall post in conspicuous places, available to employees and applicants for employment, notices setting forth the provisions required by the Applicable Law, including, without limitation, the DM/DWBE requirements referenced in Exhibit K and all other federal, state and local fair employment laws, orders, regulations and ordinances. Contractor shall abide by any additional special provisions that may be mutually agreed upon as part of this Contract

11.10.3 To the extent required by Exhibit K Contractor shall ensure participation by business enterprises that are owned by minorities, females and the disabled per Applicable Law and the said Special Conditions of the Contract. Contractor shall bind its Subcontractors and vendors to similar requirements. Contractor understands that County may be obligated to ensure such participation and may suffer sanctions for failure to do so. Should any sanction be imposed upon County for noncompliance and such noncompliance is solely attributable to the Contractor, Contractor shall be assessed responsibility for the sanction.

11.11 Notices

Formal Notices and consents required or permitted by this Contract shall be in writing and may be delivered by hand, recorded express delivery or certified mail, return receipt, all costs and fees pre-paid with Notice deemed to have been given upon receipt, addressed as follows:

If to County:	Lee County Contracts Management P.O. Box 398 Fort Myers, Florida 33902-0398
Copies to:	Lindsey J. Sampson - Director Lee County Solid Waste Division 10500 Buckingham Road Suite 200 Fort Myers, FL 33905  Lee County Attorney 2115 2 <sup>nd</sup> Street, 6 <sup>th</sup> Floor P.O. Box 398 Fort Myers, FL 33902  Covanta Lee, Inc. 40 Lane Road P. O. Box 2615 Fairfield, New Jersey 07007-2615 U.S.A. Attention: Project Manager
If to Contractor:	Tampa Tank, Inc. 5205 Adamo Drive Tampa, Florida 33619 813-623-2675 Attention:                    Attention: Project Manager

Changes in the respective addresses to which such Notices shall be directed may be made from time to time by either Party by Notice to the other Party.

11.12 Law/Jurisdiction

The Parties consent to the jurisdiction of the courts (including Federal Courts) of and in the state of Florida. The laws of that state (without giving effect to its conflict of laws principles) shall govern the validity, interpretation, construction and performance of this Contract.

11.13 Entire and Complete Contract

This Contract together with all Exhibits, Change Orders and any other valid amendments and annexures constitutes the entire and complete agreement of the Parties with respect to the accomplishment of the Work, superseding all prior or contemporaneous understandings, arrangements and commitments, all of which, whether oral or written, being superseded and merged herein.

11.14 Binding Effect

This Contract shall be binding upon and inure to the benefit of the Parties, and to any successor or assignee validly acquiring an interest hereunder consistent with this Contract.

11.15 Other Documents

Each Party agrees to execute and deliver any instruments and to perform any acts that may be necessary or reasonably requested in order to give full effect to the intent and purpose of this Contract.

11.16 Waiver

Unless otherwise specifically provided by the terms of this Contract, no delay or failure to exercise a right whether or not resulting from any breach of this Contract shall impair such right or shall be construed to be a waiver thereof. Such right may be exercised from time to time and as often as may be deemed expedient. Any waiver shall be in writing and signed by the Party granting the waiver. If any representation, warranty or covenant contained in this Contract is breached by either Party and thereafter waived by the other Party, such waiver shall be limited to the particular breach so waived and shall not be a waiver of any other breach under this Contract.

11.17 Visitors, Photographs, Security

Contractor shall be responsible for the security and protection of the Project Site. Visitors shall be restricted, controlled, and protected. No photographs or video recording will be permitted without the prior approval of Covanta.

11.18 Third Party Rights

This Contract is not entered into for the benefit of any third party not specifically designated herein as an intended beneficiary and no rights shall arise from or be deemed to be granted herein or hereby to or for the benefit of any such third parties.

11.19 Severability

In the event that any provision of this Contract is held to be unenforceable or invalid by any court of proper jurisdiction, the remaining provisions shall be construed to reflect the Parties' original interest and intent as closely as possible without giving effect to the invalidated provision.

11.20 Survival of Obligations

Notwithstanding County's Acceptance of the Work or the termination of this Contract pursuant to its terms, any duty or obligation of Contractor and which has not been fully observed, performed and/or discharged and any right, unconditional or conditional, which has been created for the benefit of County or Covanta and which has not been fully enjoyed, enforced and/or satisfied (including but not limited to the duties, obligations and rights, if any, with respect to confidentiality, secrecy, indemnity, warranty, guaranty) shall survive such Acceptance or termination until such duty or obligation has been fully observed, performed and or discharged and such right has been fully enjoyed, enforced and/or satisfied.

11.21 Headings

Captions and headings in this Contract are for ease of reference only and do not constitute a part of this Contract.

11.22 Counterparts

This Contract may be executed in more than one counterpart, each of which shall be deemed an original.

END OF ARTICLE



IN WITNESS WHEREOF, the Parties have caused this Contract to be executed in their respective corporate names by their respective officers, duly authorized, as of the day and year first above written.

ATTEST: CHARLIE GREEN

\_\_\_\_\_  
Deputy Clerk

LEE COUNTY, FLORIDA

By: \_\_\_\_\_

Name:

Title:

CONTRACTOR: Tampa Tank Inc.

By:  \_\_\_\_\_

Name: James E. Daniels

Title: Vice President

APPROVED AS TO LEGAL FORM AND CONTENT

\_\_\_\_\_  
OFFICE OF THE LEE COUNTY ATTORNEY

APPROVED AS TO LEGAL FORM AND CONTENT

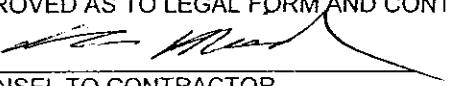
  
\_\_\_\_\_  
COUNSEL TO CONTRACTOR

**EXHIBIT A**  
**GENERAL CONSTRUCTION REQUIREMENT**

## Exhibit A

### GENERAL CONSTRUCTION REQUIREMENTS

A1000	Summary of the Work
A1001	Work Included Under this Contract
A1002	Priority of Documents
A1003	Key Personnel
A1004	Contract Administration by all Parties
A1005	Cooperation with Covanta and County Contractors
A1006	Construction Indirects
A1007	Subcontracts
A1008	Terminal Points
A1010	Construction Practices
A1015	Document/Site Inspection
A1021	Construction Area Limits
A1022	Coordination with Covanta and County Activities
A1023	Work Hours
A1024	Noise
A1025	Salvage
A1026	Cutting and Patching
A1030	FIELD ENGINEERING
A1031	Grades, Lines and Levels
A1035	Protection of Existing Services and Structures
A1080	APPLICABLE CODES
A1090	DEFINITIONS
A1200	PROJECT MEETINGS
A1210	Preconstruction Conference
A1220	Progress Meetings
A1300	SUBMITTALS
A1305	Communications
A1310	Construction Schedules
A1320	Basic Submittals/Deliverables
A1325	Jurisdictional Approvals
A1340	Drawings, Specifications, Shop Drawings, Product Data and Samples
A1345	Requests for Information (RFI's)
A1350	Operation and Maintenance Instructions
A1400	QUALITY CONTROL
A1402	Technical Control
A1403	Inspection Notification
A1404	Inspection and Testing
A1405	Testing Laboratory and Inspection Services
A1407	Non-Conformance Reports (NCR's)
J1410	Records, Test Reports, Certifications, Etc.
A1420	Punch Lists
A1500	TEMPORARY FACILITIES AND CONTROLS
A1501	General
A1502	Traffic Ways, Site Access and Vehicles
A1503	Offices and Storage Space for Contractor
A1504	Construction Equipment

- A1505 Utilities
- A1506 Sanitary Facilities
- A1507 Housekeeping and Waste Collection
- A1508 Dust Control
- A1510 Safety
- A1511 Fire Prevention
- A1512 Open Burning
- A1513 Explosive Gases (incl. Methane Precautions)
- A1520 Security
- A1521 Identification of Employees
- A1530 Manpower
- A1540 Coordination
- A1600 MATERIALS AND EQUIPMENT
- A1610 County-Furnished Equipment
- A1620 Transportation and Handling
- A1630 Receiving, Storage and Protection
- A1635 Receiving Reports
- A1640 Substitutions
- A1650 Tools and Spare Parts
- A1660 Lubricants
- A1700 START-UP (see Exhibit L)
- A1800 CONSTRUCTION CLOSEOUT
- A1850 Record (As-Built) Drawings
- A1860 Aperture Cards

**Notes:**

- 1. The term "Covanta" as used in this exhibit refers to the County's construction manager and as described in the Contract.**
- 2. The term "Resident Construction Manager", and "RCM" as used in this exhibit refer to Covanta's on-Site construction manager.**
- 3. The terms "General Contractor" and "GC" as used in this exhibit refer to another party involved in the Project under contract to the County as a "County Contractor".**
- 4. The term "Contractor" as used in this exhibit refers to the contractor performing Work under this RFP/Contract.**
- 5. The term "County Contractor" as used in this exhibit refers to the other parties involved in the Project under contract to the County, including Covanta.**

#### A1000 Summary of the Work

Contractor shall furnish and erect the scope of work detailed in the Technical Specifications, and including the Work necessary in accordance with the Exhibits depicted in this Contract.

#### A1001 Work Included Under This Contract

Unless otherwise described in this Contract, Contractor shall perform the following as it applies to its field construction scope of Work:

- a) Labor, supervision, tools, equipment and testing as necessary during the construction period and the initial operation period to make all adjustments, inspections, balancing of rotating equipment, and tests, to place all Contractor-installed equipment, accessories, and systems into commercial operation.
- b) Furnish and install temporary facilities and utilities for the physical Work and for its field offices as may be required to properly execute, maintain, protect, test, supervise and manage the Work.
- c) Furnish all tools and materials, welding machines, welding materials, weather protection, gasketing, hardware, sealants, lubricants, scaffolding, temporary stairs, floors, ladders, platforms and railings as required; all shoring, rigging, cable, stress relieving equipment including charts, plate and pipe samples as required for instructing, testing, and certification of welders, including machining and testing of samples; radiographic equipment and services for examination of field welds; labor and pumping equipment for hydrostatic tests, small tools, and all other such items needed for a complete installation.
- d) Furnish drawings, data, and calculations on materials and equipment specified or as otherwise required to complete the Work, other than proprietary data.
- e) Prepare Bills of Materials for all bulk materials and specialty items to record the applicable quantities for a complete installation and provide such data to Covanta, as requested. Any references to material quantities shown on drawings shall be used for guidance only.
- f) Furnish, install and dispose of all materials required for mechanical and electrical testing as required by code and specification. Unless otherwise noted, notify Covanta of results no later than 48 hours after test data has been collected and evaluated.
- g) Furnish to Covanta all manuals and extended warranties for installation, operation, and maintenance of equipment and systems procured by Contractor.
- h) At completion of Work, Contractor shall:
  - remove all its extraneous materials and dispose as directed.
  - remove all temporary facilities provided by Contractor.
  - clean-up and restore Site and Project areas disrupted as a result of Work performed by Contractor and Subcontractors under its supervision.

- I) Products which contain asbestos are prohibited. This prohibition includes items such as packings and gaskets even though the item is encapsulated or the asbestos fibers are impregnated with binder material.

#### A1002 Priority of Documents

In the event of conflict in the information and requirements contained in the various documents which describe the Work, the order of priority shall be (highest priority first):

- applicable laws, statutes, codes, standards, regulations and permit requirements
- Change Orders to this Contract
- the terms and conditions of this Contract
- Exhibit B – Design – Plans and Specifications
- Exhibit F – Responsibility Matrix
- this Exhibit A
- Balance of Exhibits

Regardless of priority, all conflicts of information must be brought to the attention of Covanta and County for resolution.

#### A1003 Key Personnel

Key personnel assigned to the Project by Contractor shall be approved by Covanta. Key personnel assigned to the Project shall remain on the construction team for the duration of the Project. Personnel assignments shall only be changed due to separation from the company, personal hardship, extended delay in the Project schedule of 90 days or more, or Covanta request.

At anytime in the Project, Covanta may request a change in the key personnel or any other person assigned to the construction. This request shall be honored and implemented within 14 days.

Covanta shall have the right of approval for all key personnel. Upon proposing an individual for one of these positions, Contractor shall submit a resume to Covanta's Project Manager and arrange for a face-to-face interview to qualify the candidate. Approval of the candidate shall be solely at Covanta's discretion.

Key personnel shall include (as applicable):

- Project Manager
- Lead site superintendents:
  - civil
  - structural
  - mechanical
  - electrical
  - instrumentation & control
- Start-up Manager

For each of the above, detailed resumes shall be submitted for Covanta review within fifteen (15) Days of said persons' assignment to the Project.

#### A1004 Contract Administration by All Parties

Contractor shall provide the following services in the execution of its responsibilities under this Contract:

1. Perform schedule reviews, planning and coordination of all shop and field fabrication, installation and construction activities for the Work. Provide copies to Covanta.
2. Provide construction schedules and reports required by Covanta, as follows:
  - a) on a monthly basis and in a timely manner, provide all information required to satisfy the reporting requirements of Exhibit E;
  - b) three week (minimum) lookahead schedules (issued weekly);
  - c) daily manpower count, by tradesmen categories (issued weekly);
  - d) Contractor shall incorporate the schedules and reports of its Subcontractors.
  - e) attend initial and periodic CPM schedule reviews;

Prepare schedules for direct hire and subcontracted Work in accordance with the Master Project Schedule referred to in Exhibits D and E, and actively participate in meetings in accordance with provisions of this Contract. Emphasis will be to inform Covanta and the County of planned Work, coordination of deliveries and installation activities, attention to community and County issues, coordination with Existing Facility operations and maintenance, and other pressing matters.

3. Monitor, expedite and report on tradesmen and Subcontractor progress and performance in accordance with the established schedules.
4. Contractor shall submit for Covanta and County review (within fifteen (15) Days of Notice to Proceed) its phased Site development plans showing temporary services, temporary buildings and trailers, laydown and pre-assembly areas for all its Subcontractors, warehouse(s), shop buildings, welding facilities, security gates, craft parking, drainage, miscellaneous facilities needed for the Project, and other features as requested by Covanta and County. Contractor shall work with Covanta and all other County Contractors to develop a workable Site development plan.
5. Inform Covanta of planned areas of Work at least one week in advance of actual performance of such Work. All Work shall be coordinated with other construction activities and shall not interfere with Existing Facility operations and maintenance unless approved in advance by Covanta. Advise of possible impacts on neighbors.
6. Perform value engineering and constructibility reviews of related construction documents prepared by other parties where they interface with Contractor's Work.
7. Contractor shall arrange and coordinate its Work, be responsible for acts and omissions of all of its parties involved in the Work, be responsible for satisfactory performance of all Work, ensure that each trade is fully informed of the full extent of Work required, and coordinate installation of all equipment and shop fabricated material, including that supplied by others within and/or for its Work.
8. Contractor shall make application and assist its Subcontractors in obtaining mechanical, plumbing, electrical or any other licenses, permits or approvals which may be required for it to do Work in the jurisdiction of the Facility. The Contract Price includes the cost of such



permits, fees, licenses, approvals, etc.

9. With Covanta assistance where appropriate, maintain a Safety Program, postings of permits, wage rates, etc., as required by Applicable Law and by Special Conditions, if any.

#### A1005 Cooperation with Covanta and Other County Contractors

County will be contracting directly for the supply and erection of certain major items of equipment and systems defined elsewhere in this Contract. The General Contractor ("GC") and Covanta shall be in charge of the Site and shall furnish Project and construction management services to coordinate and administer all contractors, including County Contractors, participating in the Project.

GC and Covanta assume no liabilities with regard to Contractor's or any other County Contractor's schedule, quality, safety or performance. The GC or Covanta shall have no authority to alter the terms and conditions of the Contract or other contracts with County Contractors.

Contractor shall cooperate with and provide input to Covanta, and GC where applicable, which will allow Covanta and the GC to accomplish certain construction management responsibilities.

Contractor shall undertake the following as a part of its Work:

- A. Contractor shall provide management and construction field engineering personnel to oversee, interface and coordinate the tradesmen performing the Work and to interface and coordinate with County Contractors, including County's equipment suppliers where County provides equipment to Contractor for installation on the Site.
- B. Contractor shall provide detailed resumes for their lead construction management person in each applicable discipline and for start-up manager for Covanta's review within fifteen (15) days of said persons' assignment to the Project.
- C. Provide, as required by the Contract, construction schedules and reports (which incorporate the schedules, activities, plans and reports of Contractor and its Subcontractors) in a timely manner, and provide all information required to satisfy the general reporting requirements of Exhibit E.
- D. Conduct periodic onsite coordination meetings with Covanta, County, and/or County Contractors as requested by Covanta.
- E. Monitor, review and report on the rate of progress for the Work and provide substantiation for its applications for progress payments from same.
- F. Contractor shall monitor the quality assurance program of all parties providing any component of the Work, and shall actively enforce the specification requirements and Contract documents related to workmanship.
- G. Review and monitor the health, safety and cleanliness programs and practices of Contractor and all Contractor's Subcontractors to ensure their conformance to the Contractor's and Project's programs and Applicable Law requirements. Police all Site areas for cleanliness, and report repeated, documented violations to Covanta.

- H. Contractor shall administer a program to collect data, report the data to Covanta and the County, and, if requirements are applicable, report on compliance and recommend enforcement actions for all Contractor parties on the Site in regard to the following, as applicable to the Project:
- local procurement and contracting
  - other host community programs
- I. Contractor shall assist its Subcontractors in obtaining their licenses, permits and approvals required for them to do Work in the jurisdiction of the Project.

#### A1006 Construction Indirects

Contractor shall provide all its construction indirect materials and services required for Contractor to perform its Work in the jurisdiction of the Project, including, but not limited to:

- Mobilization and demobilization
- Temporary Construction:
- Building and trailers - administration offices, change houses, warehouse, tool storage room, weather protection for equipment and personnel, miscellaneous temporary structures, etc.
- Shops - crafts shops
- Services and utilities (per this Exhibit A)
- Scaffolding, crane mats, erection incidentals
- Construction Equipment:
- Automotive
- Equipment (Heavy & Light)
- Small tools
- Expendables/Consumables
- Testing and inspection services
- Material handling
- Construction housekeeping and final clean-up
- Seasonal operations (e.g., winter, tomado, hurricanes, heavy rains)
- Warehousing, welder qualifications
- Premium pay, shift differential (if required)
- Labor expense and benefits
- Permits and licenses

Contractor shall also provide materials and services as required by the general construction requirements specified, and not limited by, Attachment A-1 to this Exhibit.

#### A1007 Subcontracts

Prior to selection of and entering into any agreements with Subcontractors, it is mandatory that Contractor submit to Covanta the names and qualifications of firms it proposes to use, especially for the following (as applicable to its Work):

- all testing, inspection and QC firms to be employed for the Work
- structural steel fabrication
- piping fabrication
- piping and mechanical installation
- HVAC fabrication and installation

- electrical and instrumentation work
- fire protection and detection

Qualification documents for Subcontractors shall include information regarding:

- valid contractor license
- valid professional engineer registrations (for documents submitted to code enforcement agencies)
- technical capabilities and related experience
- financial position
- insurance and bonding capability
- recent litigation
- QA/QC program
- safety, security and housekeeping practices

#### 01200 Terminal Points

Exhibits B, F and balance of Contract defines Contractor's limits of Work, terminal points and interface points for various systems. Necessary co-ordination with Covanta and County Contractors shall be considered by Contractor while planning the overall Work schedule. All rights-of-way required for Work to be undertaken by Contractor will be arranged by Covanta.

#### A1005 Construction Practices

Contractor shall implement procedures in order to minimize vehicle and equipment noise, dust generation, construction vehicle traffic impacts, and to ensure worker safety. Contractor shall be responsible for informing all its Subcontractors, employees and other individuals involved with construction of the requirements herein and shall assume responsibility for ensuring compliance.

#### A1015 Document/Site Inspection

Before commencing with the Work, Contractor and all its Subcontractors shall inspect the Issued for Construction Specifications, Drawings and Contract attachments and verify all field conditions and dimensions at the Site. Contractor shall promptly notify Covanta of any discrepancies.

Failure to review and confirm all available information, site conditions and regional physical and environmental conditions will not relieve Contractor from the responsibility of properly completing the Work within the Contract Time or Milestones.

#### A1021 Construction Area Limits

Covanta will designate the boundary limits of access road, parking areas, material storage area, space for office trailers and craft trailers, and other construction areas to be shared by Contractor and all other County Contractors for the Project. The Contractor shall be responsible for keeping all of his personnel out of areas not designated for the Contractor's use - violation of this requirement shall subject such personnel to permanent removal from the Project at Contractor's sole expense. The Contractor shall have unrestricted access to the Project site at all reasonable times prior to completion of Work.

#### A1022 Coordination with Covanta and County Activities

Contractor shall coordinate all Work with Covanta activities, including other County Contractors, and Covanta's Existing Facility operations and maintenance. Except for an emergency, Contractor shall not interrupt temporary or permanent heat, light, power, water, sanitary and other services without notification and permission of Covanta.

Under no circumstances, without the express written consent of Covanta, shall the Contractor, its subcontractors or its employees use or move Covanta facilities, tools, or equipment which were not assigned for their use. In the event that the occasion arises that plant personnel is required for the removal or relocation of equipment interfering with the Contractor's Work, Contractor shall inform the Covanta [Covanta] in advance of any impacts. Covanta will arrange to assign personnel to clear the interference.

#### A1023 Work Hours

Contractor shall advise Covanta of its standard work hours at the beginning of construction. Thereafter, any deviation to those hours will be submitted to Covanta in writing at least 48 hours in advance. Work shall not be conducted during hours which violate Applicable Law or which may be reasonably objected to by Covanta or County. For such construction outside the regular hours, Contractor shall illuminate the different parts of the construction in a proper and safe manner.

During the start-up and commissioning period, at Covanta's request, (a) Contractor's support labor, (b) representatives of Contractor-furnished equipment and (c) associated construction personnel, tools, equipment and services must be provided twenty-four (24) hours per day, seven (7) days per week as scheduled by Covanta.

No construction shall be performed without the presence of a representative of Covanta (or necessary inspector per Applicable Law) at the Site unless otherwise stipulated by Covanta in writing prior to performance of said construction.

Contractor's supervisory personnel shall be present during all hours for which its labor, including that of its subcontractors are engaged in Work.

#### A1024 Noise

Exhaust silencers or mufflers shall be maintained on all construction equipment, and exhaust emissions shall be in compliance with Applicable Law;

Unnecessary idling of all heavy construction equipment shall be prohibited;

Pile driving and other major noise-producing construction and/or commissioning activities shall be confined to the working hours of 7:00 A.M. to 7:00 P.M., or as otherwise stipulated by Applicable Law, as shall construction activities occurring near the Site perimeter.

#### A1025 Salvage

Contractor shall carefully remove and segregate all salvageable (as solely determined by County) equipment and materials as directed and placed where instructed on the Site or at County's recycling facility adjacent to the Site. Ownership of salvageable items shall be retained by County unless stipulated otherwise in this Contract.

A1026 Cutting and Patching

Contractor shall cut any existing construction as required for all new Work. All cut and damaged work shall be patched and finished to match the existing construction in an approved, workmanlike manner and to the satisfaction of Covanta and County.

A1030 FIELD ENGINEERING

A1031 Grades, Lines and Levels

The Contractor shall establish the location of lines, grades and benchmarks from known reference points, shall verify existing or "as-built" lines and grades. Contractor shall provide services related to surveying, as needed to properly complete its Work. Licensed surveyors shall be used.

Surveyor's services shall be to the account of Contractor as and when needed to properly align, plumb and complete its Work. Such services shall include all material, labor, supervision, tools, conveyance, and equipment required for accomplishing its survey work. Copies of all surveys shall be provided to Covanta.

A1035 Protection of Existing Services and Structures

Within its work area(s), Contractor shall investigate, locate and mark the locations of all existing and newly constructed underground piping, underground utilities, underground tanks and vaults and other similar hidden items. Contractor shall make provisions for the protection of aboveground buildings, landscaping and other property on the Site or which may be impacted by Contractor (e.g., roadways, structures, etc.).

A1080 APPLICABLE CODES

All conflicts between the requirements of this Contract and the specifications, standards and drawings and their modifications, if any, must be referred to Covanta and County for clarification before proceeding with the design, purchase, manufacture or erection of the affected parts. In the absence of written clarification, the most stringent requirements shall govern.

Contractor shall comply with the intent of the codes, standards, specifications, regulations, procedures and tests of the organizations which have jurisdiction over this type of project and over elements of the Project, including the following (or equivalent standard for Project outside the U.S.A.):

ACI - American Concrete Institute  
AMCA - Air Moving and Conditioning Association  
ANSI - American National Standards Institute  
ASME - American Society of Mechanical Engineers  
ASTM - American Society for Testing and Materials  
AISC - American Institute of Steel Construction  
AISI - American Iron and Steel Institute  
AGMA - American Gear Manufacturers Association  
AWS - American Welding Society  
Edison Electric Institute - Electrical Power Plant Environmental Noise Guide  
HEI - Heat Exchange Institute  
HI - Hydraulic Institute

IEEE - Institute of Electrical and Electronic Engineers  
ISA - Instrument Society of America  
MBMA - Metal Building Manufacturer's Association  
NEC - National Electric Code  
NEMA - National Electric Manufacturers Association  
NBFU - National Board of Fire Underwriters  
NFPA - National Fire Protection Association  
OSHA - Occupational Safety and Health Administration  
TEMA - Tubular Exchanger Manufacturers Association

Applicable federal, state and local laws, codes, regulations and ordinances.

Unless noted otherwise, where Applicable Law requires review by regulatory agencies of design work performed by Subcontractors of Contractor, such applications and submittals shall be in a timely manner and costs shall be borne by Contractor.

The technical terminology used in the Work and the Specifications shall be defined by the applicable code.

#### A1090 DEFINITIONS

The following definitions supplement definitions of this Contract, General Conditions, Special Conditions and other general Contract documents.

Architect - Synonymous with Engineer

Architect/Engineer - Synonymous with Engineer

Approved/Reviewed - These words, when applied by Reviewer to Contractor's drawings or documents, means that the drawings or documents are satisfactory from the standpoint of interfacing with all furnished components of the installation, and that the Reviewer has not observed any statement or feature which deviates from the specification requirements. Contractor shall retain entire responsibility for complete conformance with all of the specification's requirements.

Approved as Noted/  
Reviewed as Noted

These words, when applied by Reviewer to Contractor's drawings or documents mean that the drawings or documents are satisfactory as defined above, except that the changes shown are required for the proper interfacing with furnished components of the installation or are necessary to be in conformance with the specification's requirements. On the basis that Contractor shall retain the entire responsibility for compliance with all of the specification's requirements, Contractor shall either incorporate the change into his drawing or inform the Reviewer that the changes cannot be made without prejudice to Contractor's responsibility under warranty. Drawings will be rejected if they do not satisfy the intent of the specification or are not of the quality required for this project.

Furnish - Supply and deliver to Site ready for unloading, unpacking, assembly

		and installation.
IFC	-	Issued for Construction
Install	-	Unload, unpack, store (if necessary), assemble, erect, place, anchor, apply, finish, etc.
Minimum Requirements	-	Indicated requirements are for a specified minimum acceptable level.
MRR	-	Material Receiving Report
NCR	-	Non-Conformance Report
NTP	-	Notice to Proceed issued to Contractor by County
OS&D	-	Over, Short and Damage Report
Provide	-	Furnish and install, complete and ready for intended use.
Reviewer	-	refers to Covant and/or Engineer under contract to County where detailed engineering is <u>not</u> by Contractor.
RFI	-	Request for Information
Subcontractor	-	Contractor's subcontractor
County Contractor,- OM(Sub), or C(Sub)	-	Contractor performing work directly under contract to County

#### A1200 PROJECT MEETINGS

##### A1210 Preconstruction Conference

Covanta may arrange for a meeting with Contractor to discuss in detail mobilization and the construction schedule in order to provide for the most expeditious and economical construction.

##### A1220 Progress Meetings

Covanta and Contractor shall arrange and attend periodic progress meetings. The frequency of these meetings will normally be on a monthly basis unless otherwise determined by Covanta or as demanded by construction activity. Such meetings will include Contractor, its Subcontractors, Engineer and/or other County Contractors when directed by Covanta.

#### A1300 SUBMITTALS

##### A1305 Communications

All correspondence from Contractor shall contain the following subject heading:

Letter/Transmittal No.  
Project Name: Lee County WTE Expansion Project  
Covanta Project No.: C-14530001  
\*Spec No. Reference:  
\*Spec Issue Date:  
\*Drawing No.:  
\*Drawing Rev. No.

\*If Applicable

All correspondence from Contractor shall be addressed to the Covanta's Project Manager with simultaneous transmission to County, RCovanta, and to other individuals as required by Covanta or County.

A1310 Construction Schedules

Refer to Exhibit H of the Contract for requirements.

A1320 Basic Submittals/Deliverables

Notwithstanding more specific, detailed requirements elsewhere in this Contract, the following are the minimum requirements for various submittals by the Contractor. Contractor shall submit their supporting documentation to Covanta reasonably in advance of the below-listed due dates.

<u>Due Date</u>	<u>Submittal</u>	<u>Covanta Project File</u>
Contract Award + 30 Days	Factory Test Schedule	
First presence on site	Proof of valid license with appropriate governmental agency	
First presence on site	Certificate of Insurance for each Subcontractor (including annual renewals, if applicable) (Contract terms)	(4.9) Cert. of Ins.
First presence on site	Names and phone numbers for emergency contacts	(7.7) Safety
Prior to start of Work at Site	Plan for storage, transportation and disposal of any hazardous materials	
NTP + 14 days	Preliminary Drawing Schedule	
NTP + 15 days	Site Development Plan	(9.2) Dev. Plan



NTP + 30 days	QA/QC Program and Manuals	(9.10) QA/QC Program
NTP + 30 days	Crisis Communication List	(3.5) Phone List
NTP + 30 days	Subcontract Procurement Schedule	
NTP + 30 days	CPM Schedule	
NTP + 30 day	Deliverables for Progress Payments	
NTP + 45 days	Site Security Procedures	(3.3) Site Security
NTP + 60 days	Safety Program and Manuals	(7.7) Safety
NTP + 120 days	Final CPM Schedule	
Turnover + 30 days for specific equipment/system <u>furnished</u> by Contractor	As-built drawings & other deliverables to close-out Contract	Engineering Dept.
120 days before Substantial Completion	Functional Test Procedures (Contract Terms ¶(3.8))	
30-45 days prior to Start of Testing	Notice of Start of Performance Test	
Monthly Update	Master Project Schedule	
Monthly	Installed Quantity	
Monthly	Progress Reports	
Weekly Update	Manpower	
Weekly Update	Progress & Weekly Look Ahead	
Monthly	Acoustic Analysis	
Monthly	Power Consumption	

A1325 Jurisdictional Approvals

Contractor is obliged to submit all documents necessary and to attain timely review and/or approval of such documents and physical Work by governmental agencies and/or authorities having jurisdiction over its Work.

A1340 Drawings, Specifications, Shop Drawings, Product Data and Samples

Contractor shall furnish simultaneously to Covanta, County, and the Engineer for review drawings, data and calculations on materials and equipment required for the control and completion of its Work **(as applicable to its Scope of Work)**. These drawings/data/calculations shall include, but are not limited to the following areas, as applicable to the Work:

- All engineered drawings
- Vendor equipment drawings
- Data and calculations for sizing/selection of materials and equipment
- Roofing and siding (catalog cuts)
- Pipe hangers and supports
- Field-run, small bore piping
- Instrument process piping details
- Instrument air supply and control air piping
- Steel fabrication (including any truss calculations, P.E. sealed)
- HVAC equipment and accessories
- Fire detection/protection systems
- Site welding procedures/qualifications (ANSI B31.1 or non-U.S.A. equivalent)
- Pre-engineered buildings
- Precast concrete
- Concrete reinforcing bars and miscellaneous steel
- Catalog cuts and shop drawings for air conditioning unit, exhaust fans, louvers, etc.
- Test procedures and results
- Certificate of compliance for Contractor-Furnished items

All drawings and data will be subject to review by Covanta, County, and Engineer for conformity with the Contract. Drawings and data submitted by Contractor will be complete so as to allow for a meaningful review.

Within 7 days following receipt of Notice to Proceed, Contractor shall furnish to Covanta, County, and Engineer a schedule for submission of all documents intended to be submitted for the first 75 days following Notice to Proceed.

Within 60 days following receipt of Notice to Proceed, Contractor shall furnish a schedule for submission of all drawings and data on materials and equipment furnished. The schedule will be reviewed by Covanta, County, and Engineer, and Contractor shall make any correction required by Covanta, County, or Engineer. The schedule shall at all times present a complete plan for orderly submission of such drawings and data and shall be revised as necessary to meet this requirement. Contractor shall promptly notify Covanta, County, and Engineer of any occurrence requiring substantial revision of the schedule, giving a detailed explanation of the cause of the revision and shall furnish a revised schedule within ten (10) days of such occurrence. The revised schedule will be reviewed and corrected in the same manner as the original schedule and subject to the approval of Covanta, County, and Engineer.

Drawings shall be clearly identified and coordinated with the schedule by means of suitable file numbers and drawing titles. Space shall be provided on the drawing to enable Covanta and/or Engineer to add its file number.

Unless otherwise agreed, Contractor shall submit for review one print to each the County and Engineer and to Covanta one (1) high quality sepia and three (3) prints made from the original of all drawings, calculations, and data as specified in this Contract. Contractor shall check and correct all drawings and data before their submission, whether they are prepared within its own organization or by a subcontractor, and shall be responsible for a fully coordinated submission. Contractor shall furnish to Covanta or County any copies of correspondence between Contractor and its Subcontractors, between Subcontractors, or Contractor's internal correspondence as Covanta or County may request.

After review by Covanta, each drawing will be stamped either "Reviewed", "Reviewed as Noted" or "Rejected." If stamped "Reviewed as Noted", a print will be returned to Contractor who shall incorporate the changes onto his drawing and make a new submittal. All revisions to a drawing since its previous submittal shall be clearly identified. When stamped "Reviewed", a print showing the "Reviewed" stamp will be returned to Contractor.

Drawings will be rejected if they do not satisfy the intent of the specification or are not of the quality required for this project.

Review by Covanta, County, and/or Engineer of drawings submitted by Contractor shall not relieve Contractor from complete responsibility for correctness of the design or any other contractual obligations.

**Covanta, County, and Engineer reserve the right to reproduce any drawing or print received from Contractor as may be required during the design and construction of this Project and the preparation of a Facility Manual despite any notice by the supplier on the document prohibiting such use.**

#### A1345 Requests for Information (RFI's)

Contractor shall utilize a mutually agreed RFI procedure and forms for inquiries about the Work. Responses to RFI's must be complete, and each RFI must stand alone and not cross-reference other documents but have the needed information attached to close the response loop.

RFI's are to be used as the primary method for obtaining variances from the requirements of the specifications and plans. Approved RFI's are to be transferred onto the as-built record set which Contractor is required to submit to Covanta at conclusion of the Work. Merely stapling RFI's to the

as-built set is unacceptable. Covanta shall receive copies of RFI's at each issue stage. Covanta approval is not required provided there are no changes to the Project Plans and Specifications. Contractor must issue a letter to Covanta with copy to County, requesting approval of any deviations to the Project Plans and Specifications.

**A1350 Operation and Maintenance Manuals (ONLY FOR CONTRACTOR-FURNISHED EQUIPMENT)**

Contractor shall furnish operation and maintenance manuals, lubricant list, spare parts lists, certified drawings, assembly instructions, etc. Each set of manuals (in the final form) shall include a suitable title page and table of contents. The instructions shall be neatly bound in a 3-ring, hard back looseleaf binder with front cover and spine labeling of contents. The instructions shall include information covering description, installation, lubricants, operation, preventive maintenance, overhaul and a list of recommended spare parts.

The contents of the manuals shall generally be as follows:

- A. Title sheet with Project name.
- B. The names, addresses and phone numbers of Contractor, Subcontractor, control subcontractor, related contractor and material and equipment suppliers.
- C. Index of contents.
- D. A copy of acknowledgment of instruction to Covanta's operating personnel in the operation of mechanical equipment and systems, signed by Covanta or its authorized representative.
- E. Typewritten operating instructions for Covanta personnel describing how to stop and start each piece of equipment; how to set the control system for normal operation and normal restarting procedures, and caution and warning notices.
- F. Approved shop drawings, product data and parts and maintenance booklet for each item of material and equipment furnished by Contractor.
- G. Record drawings of electrical and control diagrams.
- H. Test, balance, performance or check-out report.
- I. Copies of certificates of inspection.
- J. Guarantees & warranties, including extended guarantees and warranties.
- K. Lubrication Schedule

Unless otherwise more specifically described in this Contract (e.g., by the Specifications or Attachment JA), a minimum of twelve (12) copies shall be provided. Distribution of documents shall be in the following manner:

- a) Six (6) sets in preliminary form to be delivered to Covanta at least 90 days prior to the material/equipment/subsystem turnover.

b) Balance of sets in final, complete form to be delivered to Covanta prior to the material/equipment/subsystem in-service date and as condition of final payment to Contractor.

#### A1400 QUALITY CONTROL

Contractor shall develop a project-specific Quality Assurance/Quality Control (QA/QC) program. The program must be submitted to Covanta for its review. The program must be in force no later than 30 days after Notice to Proceed.

The existence of a QA/QC program shall not relieve Contractor of its obligations under any Applicable Law.

The RCovanta may monitor Contractor's conformance with the QA/QC program; however, this does not relieve Contractor of its obligation to complete the Work in an acceptable standard of quality and workmanship.

The QA/QC program must include as a minimum the following elements (as applicable to Contractor's Scope of Work):

- reference to and compliance with local codes and standards
- procedures for submittals/approvals to comply with Applicable Law
- permit requirements
- concrete testing and inspection
- high-strength bolt conformity with specifications
- bolt tension testing and connection inspection
- welding per Applicable Codes
- transformer oil filling practices
- applications and standards for radiography and other nondestructive testing
- certification requirements

#### A1402 Technical Control

Contractor shall comply with the requirements of the QA/QC program to maintain technical control. Requests for deviation from contract documents shall be issued using the RFI procedure. Nonconforming work shall be documented and dispositioned through Covanta. The format for technical control will be established jointly by Covanta and Contractor.

#### **ALL DEVIATIONS MUST BE APPROVED BY THE ENGINEER-OF-RECORD.**

#### A1403 Inspection Notification

Contractor shall give notification at least five (5) days in advance for tests, inspections and operations which may be witnessing by Covanta and/or local officials. Contractor's failure to notify appropriate parties may be cause for rejection of the results and that the activities performed without proper notification be repeated for Covanta observation at Contractor's expense.

For ease of notification of inspection and other communication, Contractor shall provide to Covanta one crystal for mobile radio with same frequency as "ALTERNATE FREQUENCY" of 2-channel radios used by Contractor's construction supervisory personnel. Contractor shall provide Covanta with one (1) compatible radio.

#### A1404 Inspection

Work shall be open continuously to inspection by Engineer, by Covanta, by County, by Independent Engineer and by local inspectors as required by Applicable Law. Problems noted by such inspections shall be documented and transmitted to Contractor for rectification. Work covered by Contractor which has not been inspected will be reopened by Contractor. Unless otherwise described in this Contract, all costs for such uncovering and reinstalling will be borne by Contractor.

Contractor shall document various attributes of the installation to provide a history of the Work and establish base line data for operation. The documentation (as applicable to Contractor's Scope of Work) shall include but not be limited to: concrete quality, structural steel erection records, piping hydrotest records, soil compaction test records, alignment list/records, meggar records, cable pulling and termination records, instrument test records, etc.

#### A1405 Testing Laboratory and Inspection Services

Unless otherwise prescribed in this Contract (e.g., Exhibits and the Specifications), Contractor shall engage recognized independent testing laboratories and/or inspection services (certified by the appropriate state or local agency), approved by Covanta, to conduct the inspection and testing required by Applicable Law or as described in the Specifications. Contractor shall make payment for all such inspection and testing.

All reports of testing laboratories shall show the actual results of tests, the pertinent code and/or specification criteria for acceptance and shall bear a statement that the material tested does or does not conform to the Applicable Law or Specifications. All reports shall be reviewed and certified by the testing laboratory.

The testing laboratory/service shall evaluate and report all test results simultaneously to Contractor, RCovanta, the Engineer, and if required, regulatory/code officials.

#### A1407 Non-Conformance Reports (NCR's)

Contractor shall abide by the NCR procedure established by Covanta for its projects and shall use forms provided by Covanta or otherwise approved by Covanta.

#### A1410 Records, Test Reports, Certifications, Etc.

Contractor shall make all installation documents, i.e., inspection data, test reports, mill tests, concrete tests, weld tests, chemical analyses, as-built drawings and such similar records immediately available to Covanta. Records must be transmitted to (or if proprietary, made available for review by) the Covanta and to the RCovanta within 5 working days of test completion to consider the testing valid and be cleared for payment of Work tested, unless waived in writing by Covanta.

Radiographic films, dye penetrant, magnetic particle and ultrasonic testing reports of shop and field welds shall be made available for review at Contractor's field office.

Where required by Applicable Law and/or condition of any permit, Contractor shall at the conclusion of its Work provide written certification by a Professional Engineer (validly licensed in the jurisdiction of the Project) attesting to the Work being installed (a) in conformance with Contractor-furnished as-built record documents, (b) in conformance with permit drawings, specifications, calculations and catalogue cuts (as applicable), and (c) in conformance with specific code, statute, regulation, ordinance, etc.

Appropriate reports and certifications (e.g., inspection and testing procedures, Contractor-designed systems, grounding, plans and specifications, etc.) must be sealed by a professional engineer licensed in the jurisdiction of the Project.

#### A1420 Punch Lists

Contractor shall correct all its construction deficiencies identified by Covanta, Engineer, and/or County and documented in punch lists.

#### A1500 TEMPORARY FACILITIES AND CONTROLS

##### A1501 General

Except where specifically indicated otherwise in the Contract documents, Contractor shall provide temporary services to fully satisfy construction activities. Contractor shall bring the services to suitably located service points and elevations from which all Site contractors (including County Contractors) can make their service connections.

Contractor shall make, maintain and remove at its own expense connections at point of supply and also provide and maintain its own piping and/or wiring for all water, air, electric power and other services required for the erection or construction Work. All such connections shall be made at points to be approved by Covanta. County shall be responsible for water and electric power source interruptions in service; subsequent impacts, if any, shall be Contractor's obligation unless the duration of such interruption(s), on an occurrence basis, lasts more than 4 hours during normal working hours.

Contractor shall provide temporary site fencing and security gates, as necessary to protect its Work.

##### A1502 Traffic Ways, Site Access and Vehicles

Work shall be scheduled, confined, and performed, as directed, so as not to interfere with the highly active traffic (associated with the operations of the Existing Facility, and adjacent transfer station, recycling and horticulture processing facilities) on the Existing Facility roads, walks, parking and other paved areas. All vehicles shall be parked in designated parking areas. Contractor shall load and unload vehicles without restricting traffic flow, emergency access or Work execution.

Contractor shall not close or obstruct any portion of a street, road, or private way without obtaining permits from the proper authorities. If any street or private way shall be rendered unsafe by Contractor's operations, he shall make such repairs or provide such temporary ways or guards as shall be required in accordance with safety requirements of Covanta or Applicable Law.

Streets, roads, private ways and walks not closed shall be maintained passable by Contractor at its expense, and Contractor shall assume full responsibility for the adequacy and safety of provisions made.

Contractor shall, 72 hours in advance, notify Covanta, County and local authorities in writing if the closure of a street is necessary. Contractor shall be responsible for maintaining proper coordination with the local police and fire departments.

GC shall provide adequate measures through the use of traffic control officer(s), signs, signals, scheduling vehicles or other means of traffic control shall be provided to ensure satisfactory flow of traffic on public roadways in the immediate vicinity of the Site.

GC shall develop a Project traffic plan that includes, at a minimum, traffic at the entrance to the Existing Facility, traffic during operations of the various County facilities on and adjacent to the Site, traffic from Existing Facility maintenance and outage work, traffic from all other County Contractors. If required, such traffic plan shall be submitted and approved by the appropriate governmental agency having jurisdiction. GC shall administer and Contractor shall be responsible to comply with and strictly enforce all conditions contained in such traffic plan.

Contractor shall take necessary measures to ensure that all construction-related traffic, including construction employees' vehicles, utilize the ingress/egress plans as indicated by Applicable Law, traffic and Project permits.

All onsite roadways Contractor identified in its proposal, if any, to be required for its Work shall be graded and surfaced by GC to render them suitable for heavy equipment and materials transport and shall be graded and surfaced in a manner that prevents the generation of dust and the accumulation of surface water during their use. Such grading and surfacing shall be completed prior to initiation of full scale construction activities on site, and once completed, the roadway shall be maintained by GC for the intended use. GC shall also maintain existing site roadways used by any County Contractor for construction, including cleaning and dust control. Contractor shall be responsible for damage it causes to existing roadways.

If local situations require a two-gate system be in place, GC shall, on its account, be responsible to amend any aforesaid traffic plan and secure needed approvals without impacting the Project schedule or cost.

Contractor shall use only gates approved by Covanta for entry to the Project area.

Vehicle speed onsite shall be controlled by all parties for reasons of safety, noise, dust control, etc.

GC shall provide all temporary signs to clearly mark where visitors (of all nature) are to park.

Parking space will be available on a first come/first serve basis in a parking lot on or near the Project developed by GC. GC shall restore the parking area to its original or intended condition at completion of the Work unless otherwise directed.

Contractor shall provide and maintain clear and unobstructed access to buildings, walkways, unloading areas and emergency vehicle routes, as required. Contractor shall keep all such designated accesses free of any obstructions.

#### A1503 Office and Storage Space for Contractor

Contractor shall furnish its own temporary facilities for office and storage of tools, materials and equipment. All trailers, trailer setups and removals, and trailer hookups shall be provided by



Contractor. Space available for trailers is limited and shall be kept to a minimum, and trailers shall be arranged to maximize use of available space.

To the extent required by Applicable Law and compliance with local agency(s) having jurisdiction over the trailers, Contractor may be required to install wheelchair ramp(s) and a barrier-free environment to/in its trailer(s).

Laydown space for outdoor storage of its materials will be maintained by Contractor. Contractor shall be responsible for laydown area conditions as a result of weather, such as mud and dust. Contractor shall be responsible for its materials stored in the laydown yard and shall coordinate with all other parties the moving of materials of all subcontractors to the work areas. Contractor shall vacate Project or Work areas as may be necessary (as determined by Covanta) to allow Covanta start-up and operations personnel to use the requested areas.

#### A1504 Construction Equipment

Contractor shall provide all construction tools, equipment and machinery required to complete the Work.

Contractor shall provide its own welding apparatus.

Storage of fuels, oils, chemicals, lubricants, etc., must be in accordance with all statutes.

#### A1505 Utilities

County shall bear the cost for utilization of electricity and water by Contractor and its Subcontractors throughout their presence on Site.

Compressed Air: Construction compressed air will be by Contractor; permanent plant air will not be used for construction. Instrument grade air will be made available for instrument testing to the extent that the process compressed air systems are functionally available. Contractor will be responsible for furnishing its temporary compressors, regulators, receiver, and header from the compressor to the receiver of sufficient size to accommodate all its parties involved in the construction effort. All necessary taps for water draining, cold climate gas injection, air hose connections, etc., will be the responsibility of Contractor.

Only noise-attenuated air compressors shall be utilized.

Water: Potable water will be made available from Existing Facility sources by the County for drinking and testing. The water will be available at a point of supply approved by Covanta. Contractor will be responsible for all distribution, including temporary piping, heat tracing, hose, water cans, etc., to convey the water to its Work.

Contractor shall bear the cost of its own ice.

Construction Power and Lighting: County shall make available from an Existing Facility source electric service for temporary electric construction power, welding, temporary lighting, trailer electrical service hook-ups, security lighting and aviation warning lighting, for Site users until completion of this Contract. Contractor shall furnish and install all necessary equipment and materials for distribution of power from the Existing Facility source. Task lighting is to be provided by Contractor from a power distribution system provided by Contractor.

Contractor shall furnish all its materials and Work required to provide a temporary electrical distribution system (downstream of main incoming disconnects) as required to meet all its construction power needs. Temporary circuit breakers and power panels shall be clearly identified with an index as to power source and feeds to the various loads.

Contractor shall provide adequate illumination for all its operations and that of its Subcontractors requiring lighting. Adequate illumination shall be the minimum lighting required to provide safe working conditions.

Gas: Contractor shall furnish all types of gas as required for its Work. Gas for boiler burner start-up operations shall be provided by County.

HVAC: Contractor shall provide all temporary enclosures and all heating and cooling facilities required for the efficient prosecution of its Work and comfort of craft labor until each zone is turned over to Covanta. Contractor shall be solely responsible and shall make necessary arrangements for prevention of freeze damage to its newly installed systems and equipment until they are turned over to Covanta.

Contractor shall provide its own local task heat and trailer HVAC.

Telephone: Switch connections shall be provided on the Site by the GC for use by all parties involved in the construction effort.

Contractor shall bear the cost of its own telephone equipment and usage charges.

#### A1506 Sanitary Facilities

Contractor shall provide toilets and disposal of sanitary wastes for use by its Site personnel in adequate quantity to meet all Applicable Law with jurisdiction over the Project. The facilities shall be maintained in a sanitary condition. If approved by Covanta and County, Contractor may connect temporary toilets to sanitary sewers adjacent to the Project where such sewers exist. Wash facilities, where required by Applicable Law (e.g., OSHA) or by local collective bargaining agreements shall be provided by Contractor.

#### A1507 Housekeeping and Waste Collection

Contractor shall provide daily rubbish clean-up and shall maintain its construction area in an orderly and clean state. The work area, offices and trailer storage shall be kept free of trash, snow and ice. Walkways, ladders, stairs and the like shall be clear of obstructions. Good practice shall be used in the routing of temporary hose, pipe and electrical cables to prevent tripping hazards. Contractor is responsible for safety and good housekeeping in accordance with all regulations and correct deficient areas to an acceptable, approved condition. Contractor will be responsible for all areas or instances noted as violations.

Waste materials generated by Contractor shall be handled, stored and disposed of in accordance with state and local rules and Applicable Law.

Contractor shall be responsible for the collection of all trash generated by its Work. Each Contractor shall collect its own trash and recyclable material and deposit same in its containers onsite in locations approved by Covanta Contractor. Contractor shall make provisions for the timely removal

of rubbish from the Site. Contractor shall be responsible for the removal of snow and ice in its Work areas, temporary office, storage areas and laydown areas until the completion of its Work.

In the event that housekeeping is deemed inadequate at the sole discretion of Covanta or County, Contractor shall improve the level of cleanliness. If necessary, Covanta or County may undertake independent housekeeping which shall accrue to the account of negligent Contractor.

#### A1508 Dust Control

Vehicles transporting loose or fine-aggregate materials onto or off of the Site shall be covered, and loading and unloading operations shall be controlled to minimize dust generation.

Onsite dirt roadways shall be treated/maintained by GC to minimize dust generation. Water and other methods of dust control may be used if in accordance with Applicable Law or Project permit. Methods for control must be maintained and augmented at the discretion of Covanta or County.

Open storage areas containing fine or unbound materials shall be covered or watered when necessary to minimize dust generation.

The tracking or other means of transporting mud/dirt/dust onto paved public roads shall be minimized, and Contractor shall be responsible for prompt clean-up of any accumulations resulting from its Work. If tracking cannot be controlled, Contractor shall employ a dedicated wheel wash area with suitable surface and drainage in accordance with Applicable Law.

#### A1510 Safety

Contractor shall designate a responsible member of its organization at the Site whose duty shall be the prevention of accidents and to implement and monitor its safety programs. This person shall be Contractor's designated individual(s) (e.g., Safety Engineer(s)) designated in writing by Contractor to Covanta).

Exhibit G provides the minimum safety requirements that apply to Contractor for conducting work in and around the existing operating waste-to-energy facility (the Existing Facility), including all Contractor personnel, their Subcontractors, and any hiring hall and temporary employees hired and supervised by the Contractor. It is the Contractor's responsibility to notify and enforce all aspects of this document and all local, state and federal regulations pertaining to safe work practices of any and all of its employees while conducting its Work.

Contractor shall be responsible for the safety of its personnel and its Subcontractors' personnel under its supervision on the Site in accordance with the requirements of Applicable Law, including the Hazardous Communication Program, and Contractor's own safety program. Contractor shall provide three (3) copies of Contractor's safety manual to Covanta. All safety problems noted will be brought to the attention of Contractor for immediate correction.

A construction employee health and safety program shall be implemented which informs employees of the extent and nature of hazards that may be encountered in performing their assigned work responsibilities. Such program shall take into account that the extent and nature of hazards associated with working in and around the Existing Facility. The program shall ensure that suitable safety equipment and materials are used by employees, allowing individuals to perform their assigned work duties in a safe and healthful manner. Contractor is responsible for furnishing all its employees with required safety equipment and shall be responsible for instructing and enforcing its use. Where specialized employee safety equipment is warranted, appropriate instruction relating to the equipment's use shall be provided to the employee by Contractor.

Contractor is required to obtain and post all necessary work permits required for the performance of its Work. Failure to obtain required permits and subsequent costs and delays will be in violation of the Contract and are the responsibility of Contractor. Any expenses incurred by Covanta or County to correct this situation shall be to Contractor's account.

Contractor shall have first aid facilities in place at the Site. Emergency ambulance service shall be secured locally by Contractor in the event of an accident requiring hospitalization. Contractor shall provide and maintain its first aid supplies and facilities which may be required for its personnel in accordance with Applicable Law (e.g., OSHA).

#### A1511 Fire Prevention

Contractor shall have in place at all times a fire protection procedure approved by Covanta, County and the local fire marshal. Approval by Covanta or County does not relieve Contractor of compliance with all codes. Contractor shall provide additional fire protection as required for its Work areas in accordance with Applicable Law.

Contractor shall avoid damaging or breaching the Existing Facility yard fire loop. If Contractor's Work requires temporary shutdown of the fire loop, such shutdown shall be coordinated with the Covanta and Existing Facility staff in advance of any shutdown and the shutdown time shall be minimized. In no event shall Contractor complete its work day before its activities allow the fire loop to be reenergized. If the fire loop shutdown is to be for an extended period of time, as determined by Covanta, County, or local fire marshal, Contractor shall be responsible for temporary fire water provisions.

#### A1512 Open Burning

No open burning shall be allowed.

#### A1513 Explosive Gasses (incl. Methane Precautions)

In the event that Work is conducted with site conditions where methane or other explosive gasses and/or flammable liquids may be present, readings and record monitoring will be performed by Contractor periodically (as required by permit, Applicable Law or Contract). As appropriate to its Work, Contractor shall take necessary precautions (e.g., for excavation, ventilation, detection, breathing apparatus, etc.) for its workers in order to ensure a safe working environment.

#### A1520 Security

Contractor and all visitors shall comply with Covanta's security and visitor clearance procedures which may include but are not limited to, visitor sign in and escort, etc. Contractor shall secure the Work at the completion of each Work day. Contractor is responsible for all its equipment, tools, and the like during the course of construction.

The Existing Facility is gated. The entry gate to the Existing Facility shall be controlled by Covanta. Such gate shall be normally open during normal delivery hours and closed after such normal delivery hours.

Within 45 days of NTP, Contractor shall submit to County and Covanta its Site Security Procedures covering among other things:

- guard duties
- authorized personnel
- authorized vehicles
- permanent vehicle stickers/passes (w/controlled list)
- temporary vehicle passes
- emergency phone numbers (work and home)
- sign in/sign out procedures/logs (date, time, to see, vehicle license no., visitor name, visitor affiliation, time out)

#### A1521 Identification of Employees

Refer to Covanta's Safety and Security Manual.

#### A1530 Manpower

In addition to the reporting requirements of Exhibit E, Contractor shall provide Covanta with daily site

manpower listings for each day of the Work. The report shall detail all personnel by craft, quantity and subcontract.

Contractor shall provide a daily activity report outlining the day's activity, problems, delays, instructions received, etc. The report format will be established at the contract preconstruction meeting.

All reports shall include a summarized cover sheet and all are due to Covanta by the end of the next work day.

#### A1540 Coordination

Contractor shall coordinate all its Work activities to avoid interference with Existing Facility operations and maintenance, and other construction activities. As requested by the RCM, Contractor shall conduct weekly schedule meetings with the RCM to develop the Work for the week and to coordinate with other County Contractors, and Existing Facility operations and maintenance as necessary..

#### A1600 MATERIALS AND EQUIPMENT

**This section applies only to Contractor's items and to items in Contractor's scope as furnished by Covanta or County.**

Contractor and Covanta shall mutually agree on procedures for notification of equipment deliveries, understanding of vendors' unloading and storage requirements, compliance with installation manuals, etc.

#### A1610 County-Furnished Equipment

Contractor shall not expedite equipment or material purchased by the County unless explicitly required to do so by County. Contractor shall obtain delivery status reports from the Covanta.

Equipment will generally be provided with tag numbers to facilitate inventory control.

#### A1620 Transportation and Handling

Equipment furnished by Contractor shall be prepared for shipment by vendor in such a manner to prevent contamination of interior surfaces from introduction of foreign matter, i.e., dirt, debris, water, dampness, rust, etc.

Caps, plugs, and temporary covers shall be held securely in place to avoid loss during handling and shipment.

Equipment shall be suitably crated, boxed or otherwise prepared for shipment to prevent damage during handling and shipment. Each box, crate or component shall be marked on the outside with the shipping weight, job number and mark numbers, if any.

Equipment unsuitable for crating or packaging shall be adequately protected.

In the transport of materials and equipment, Contractor shall use only designated roads on the Site.

#### A1630 Receiving, Storage and Protection

Contractor shall perform all unloading, hauling, storage (including special storage requirements of equipment vendors), protection, reloading and rehauling of all equipment/materials furnished by it and by County (for equipment to be installed by Contractor) including equipment already in storage as required by vendor procedure or the Covanta.

**Contractor shall be responsible for the prompt unloading of equipment/materials delivered to the Site and will be held liable for any demurrage charges incurred due to failure to unload transporting vehicles promptly.**

Prior to unloading, Contractor shall inspect for OS&D and then complete the appropriate receiving forms provided by Covanta. The completed forms must be submitted to the RCM within 1 working day after receipt of material.

Storage shall be performed in a manner to maintain cleanliness, to preserve packaging, and to minimize corrosion or deterioration of materials. **Special storage instructions from the manufacturer or the procurement specifications shall apply.**

Contractor shall provide (as appropriate for the nature of the stored items) air conditioning, humidity control, heaters, heated enclosures for freeze protection, power and lubrication for storage of materials, chemicals, control panels and equipment requiring such storage (e.g., paints, motors, resins, computers, etc.). When required, heaters shall be maintained by Contractor from installation through Final Acceptance or Turnover to Covanta, whichever occurs first.

Rotating equipment which is in storage and also on foundations must be checked on a regular basis for proper lubrication and rotated manually.

Maintenance records for all material and equipment requiring some form of handling while in storage (e.g., shaft rotations and temporary motor heater) shall be provided to Covanta and County on a weekly basis.

Contractor shall provide equipment for material handling and personnel for receiving and inspecting for shipping damage, unloading, storing, maintaining, protection, and issuing to construction forces all materials covered by the Specifications. Such materials will include County-Furnished items as well as items purchased by Contractor.

Contractor shall be responsible for the receipt, storage, maintenance and safekeeping of all items from the time received until accepted by Covanta and County. Contractor shall also receive, handle and store any furnished materials returned by the construction forces. The disposition of such returned items shall be made in accordance with Covanta instructions.

**Any replacement or repair (labor and material) required for equipment improperly stored or protected, or otherwise neglected by Contractor, shall be to Contractor's account. If an OS&D report was not submitted by Contractor at the time of material receipt, the burden of such shall be on Contractor to establish damage occurred prior to receipt of the equipment or material**

#### A1635 Receiving Reports

Contractor shall receive County-furnished and Contractor-furnished equipment/material shipments

and shall inspect them for evidence of shipping damage or shortages. Visual inspection for damage shall be made before and after unloading. If shortage or damage to equipment furnished by County or Contractor is apparent, a report (see attached form) shall be submitted to Covanta within 24 hours after arrival on site. Storage locations and conditions selected shall be approved by Covanta. Storage conditions detrimental to materials and equipment shall be promptly corrected by Contractor.

#### A1640 Substitutions

If Contractor finds it necessary or desirable to make substitutions for items of material or equipment or methods of Work specified, it shall furnish to Covanta, in writing on a RFI, a complete description of the proposed substitutions and the reasons for suggesting them. The description of the proposed substitution shall include technical information and a detailed comparative analysis comparing the substitute product with one of the specified products. Contractor shall also indicate the cost savings and schedule benefit to Covanta and County.

No substitutions whatever of equipment, materials or methods specified shall be made without prior written approval by County. County reserves the right to reject any substitution request.

#### A1650 Tools and Spare Parts

All erection tools and spare parts furnished with the equipment shall be turned over to Covanta at the conclusion of erection. Any tools furnished with the equipment and used by Contractor for erection purposes shall be replaced if lost or broken, and cleaned and reconditioned before being turned over to Covanta.



A1660 Lubricant List

Contractor shall submit to Covanta a lubricant list for all Contractor-supplied equipment including the type(s) of lubricant and its technical specification, name and address of lubricant manufacturer and vendor-approved alternates or equivalent lubricant.

A1800 CONSTRUCTION CLOSEOUT

A1850 Record (As-Built) Drawings

So that Covanta may have an accurate record of the installed Work, Contractor shall, on a daily basis, maintain one complete set of prints of the Plans and Specifications marked to scale indicating the installed size, elevation and location of all equipment, structures and concealed materials, including all piping, equipment, wiring devices, appurtenances, etc., as well as other existing utilities affected by the construction. All changes made before and during construction shall be recorded on these prints as they occur. Drawings shall give accurate dimensions to concealed materials from visible fixed location points. All changes shall be neatly noted and accurately identified. Where such changes, in the opinion of Covanta are not clearly and accurately shown by Contractor, Covanta will return Contractor's marked-up drawings for revision and resubmittal. Transfer all dispositions of Requests for Information into comments, markings and changes onto the Issued for Construction Drawings. Merely attaching RFI's to drawings is not acceptable. Turn over at completion of Work all Project records (as-built drawings, cable installation and termination records, instrumentation/control calibration records, etc.). The delivery of acceptable record documents is a prerequisite to final payment.

A1860 Aperture Cards

For equipment furnished by Contractor, Contractor shall deliver to Covanta one (1) set of aperture cards for all record drawings. Preparation of aperture cards shall as specified by Covanta.

END OF EXHIBIT

**EXHIBIT B**

**Design – Plans and Specifications**

**Conformed Technical Specification No. Sm-141, dated 3/22/05**

**"Field Fabricated Steel Tanks**

**COVANTA ENERGY**

SPEC. NO. SM-141  
ISSUE 005  
DATE 06/08/01

TECHNICAL SPECIFICATION  
FOR  
FIELD FABRICATED STEEL TANKS

Facility Name: LEE COUNTY WTE EXPANSION

Location: FORT MYERS, FLORIDA

\*\*\*\*\*

This document and all information contained  
herein are the property of Covanta  
Lee County and are not  
to be used except as expressly authorized in  
writing by said company

\*\*\*\*\*

Specification Prepared By: A/E Name: Burns and Roe, Enterprises, Inc.  
Address: 800 Kinderkamack Road  
Oradell, New Jersey 07649  
Telephone: 201-265-2000

A/E Approved for Release:

1.	<u>Robert Gasperic</u>	<u>Robert Gasperic</u>	<u>12/28/04</u>
	Printed Name	Signature	Date
2.	<u>S.P. Stuchlik</u>	<u>S.P. Stuchlik</u>	<u>12-28-04</u>
3.	<u>Robert Gasperic</u>	<u>R Gasperic</u>	<u>3/22/05 CONFORMED</u>
4.	_____	_____	_____
5.	_____	_____	_____

REVISIONS

001	Initial Issue.....	01/01/87
002	Revision.....	07/20/87
003	Revision.....	01/12/90
004	Revision.....	04/12/00
005	Revision.....	06/08/01

TECHNICAL SPECIFICATION  
FOR  
FIELD FABRICATED STEEL TANKS

TABLE OF CONTENTS

<u>SECTION</u>	<u>TITLE</u>	<u>PAGE</u>
1.0	GENERAL	1
1.1	Scope	1
1.2	Work to be Provided	1
1.3	Work by Purchaser	2
2.0	TECHNICAL REQUIREMENTS	3
2.1	Referenced Codes, Standards and Other Documents	3
2.2	Codes and Standards	4
2.3	Design	4
2.3.1	General	4
2.3.2	Tank Venting	4
2.3.3	Basic Allowable Stresses	5
2.3.4	Corrosion Protection	5
2.3.5	Ladders, Stairways, Walkways and Handrails	5
2.3.6	Supports and Foundations	6
2.4	Materials and Fabrication	6
2.5	Connections and Attachments	7
2.6	Tank Design Calculations	8
2.7	Welding	8
2.8	Dimensional Check	8
3.0	EXAMINATIONS, TESTING, REPAIRS AND INSPECTIONS	9
3.1	Examinations	9
3.2	Testing	9
3.3	Repairs	10
3.4	Inspections	10
4.0	SUPPLEMENTARY REQUIREMENTS	11
4.1	Surface Preparation	11
4.2	Painting	11
4.3	Nameplates	11
4.4	Drawings and Data	11
4.5	Records	12
4.6	Preparation for Shipment	13
4.7	Schedule	13
4.8	Project Specific Requirements	13
Attachment 1	Tank Data Sheet	A1-1
Attachment 2	Documents Sumittal Schedule	A2-1
Attachment 3	Specification SA-550 "Technical Specification For Painting Ferrous Metals Included in Subcontractor's Work"	A3-1

*Attachment 4 Wind Design Information*  
*Attachment 5 overhead Transmission Line Information*

## 1.0 GENERAL

### 1.1 Scope

This specification covers the requirements for design, materials, fabrication, erection, inspection and testing of cylindrical fusion welded steel vertical storage tanks having internal fluid pressures and temperatures approximating atmospheric conditions.

Tank parts, accessories and attachments which are furnished as a regular part of proprietary or standardized equipment shall be in accordance with the tank or equipment manufacturer's standards or recognized industry standards suitable for the design conditions.

### 1.2 Work to be Provided

1. The Seller shall base his proposal on furnishing completely fabricated and erected atmospheric storage tanks in accordance with the requirements of this specification. The Seller, shall assume sole responsibility for the design, selection of materials, fabrication, erection, inspection and testing of such tanks. The Seller's proposal shall include:
  - a) The cost of furnishing all tank appurtenances and accessories specified herein or on the Tank Data Sheets.
  - b) The required inspection and marking.
  - c) The basis used for tank design including the calculated plate thicknesses.
  - d) The proposed slope of cone roofs (Preferred method of roof support to be a self-supporting cone roof, where economical. Where not economical, bidder to furnish a supported cone roof or self-support dome roof).
  - e) Shop prime painting.
  - f) A price list (including material, labor and installation costs) for nozzles sizes 2 in. through 24 in. This list will be used for the adjustment of the base price after the final nozzle sizes have been set by the Purchaser.
2. The Seller shall be responsible for the procurement of all code inspection and shall also determine and comply with the requirements of city, county, state and national codes, ordinances, or mandatory rules which apply where the tanks are to be installed.
3. Permanent ladders, stairways, walkways, platforms and handrails.
4. A complete set of detail drawings for field erection.
5. Design calculations.
6. Erection labor.
7. Labor supervision.

8. All receiving, unloading, sorting, storing, loading and hauling from the point of delivery to the storage area and to the erection site.
9. Handling, storing and protection as required to maintain all components in the as-received condition.
10. Required temporary blocking, stiffening, covering, weather protection and other temporary facilities required to protect materials, equipment and working areas during storage, erection and testing.
11. Cranes, trucks, derricks, car movers, compressors and all other hoisting, hauling and compressed air equipment, including fuel and maintenance.
12. Shoring, rigging, cable, rope, cable or rope blocks, chain hoists and devices required for moving or handling of equipment or material.
13. Scaffolding temporary stairs, floors, ladders, platforms and railings.
14. Connections for water, electric power and other services at points to be designated by the Purchaser, including supply and maintenance of necessary pipe and wire.
15. Welding machines, cable, welding rods and burning equipment.
16. Provision of a portable rod heater or leather weld pouch for each welder to protect rods from the weather.
17. Small tools and equipment such as wrenches, hammers, turnbuckles, extension cords, jacks and rollers.
18. Oxygen, acetylene, oil, gasoline, cleaning fluids and other consumable miscellaneous supplies required for use in erection. There shall be provision for safe storage of any combustible materials used during erection.
19. Any temporary buildings or structures required by the Seller for: office, change house, storage or fabrication purposes, and maintenance thereof.
20. Removal at completion of work of all temporary facilities and services provided by the Seller for execution of his work.

### 1.3 Work by Purchaser

1. Foundations, anchor bolts, supporting and structural steel, as required for mounting tank foundation supports.
2. Water for testing and cleaning purposes within 200 feet of the tank or group of tanks. The Seller shall be responsible for any heating of the test water, when required. Any reuse of test water and its disposal shall be mutually agreed by the bidder, as tank erector, and the Purchaser.
3. Electrical power (power supply is 480 V, 3 wire, 3 phase, 60 Hz).
4. All connecting piping, external to the tanks.

5. Insulation (if required).
6. Finish painting in field.

## 2.0 TECHNICAL REQUIREMENTS

### 2.1 Referenced Codes, Standards and Other Documents

The related codes, etc., shall be of the latest issue date and shall include all addenda or supplements. Any exceptions or additions to this specification will be specified on the Tank Data Sheets. If there is, or seems to be, a conflict between this specification and referenced document, the matter shall be referred to the Purchaser before proceeding with the fabrication of the affected parts.

#### API - American Petroleum Institute

- |              |  |
|--------------|--|
| API 650      | Welded Steel Tanks for Oil Storage                 |
| API Std 2000 | Venting Atmospheric and Low Pressure Storage Tanks |

#### AWWA - American Water Works Association

- |                |   |
|----------------|---|
| ANSI/AWWA D100 | Standard for Welded Steel Tanks for Water Storage |
|----------------|---|

#### ANSI - American National Standards Institute

- |             |   |
|-------------|---|
| ANSI A12.1  | Safety Requirements for Floor and Wall Openings, Railings and Toeboards |
| ANSI A14.3  | Safety Requirements for Fixed Ladders                                   |
| ANSI A64.1  | Requirements for Fixed Industrial Stairs                                |
| ANSI B16.5  | Pipe Flanges and Flanged Fittings                                       |
| ANSI B16.11 | Forged Steel Fittings, Socket-Welding and Threaded                      |

#### ASME - American Society of Mechanical Engineers

- |      |                                 |
|------|---------------------------------|
| ASME | Boiler and Pressure Vessel Code |
|------|---------------------------------|

#### AISC - American Institute of Steel Construction, Inc.

- |      |                              |
|------|------------------------------|
| AISC | Manual of Steel Construction |
|------|------------------------------|



The American Society for Nondestructive Testing, Inc.

ASNT-TC-1A Personnel Qualification and Certification in Nondestructive Testing

ASTM - American Society for Testing and Materials

ASTM Annual Book of ASTM Standards

2.2 Codes and Standards

Tanks shall be designed, fabricated, erected, inspected and marked in accordance with the applicable standard, API 650 or ANSI/AWWA D100, specified on the Tank Data Sheets and the supplemental requirements of this specification and all mandatory laws and regulations applicable at the installation site.

Unless otherwise specified on Tank Data Sheets, design, materials, fabrication, inspection and testing of heating and cooling coils shall be in accordance with the requirements of ASME Boiler and Pressure Vessel Code, Section VIII, Division 1, Rules for Construction of Pressure Vessels.

2.3 Design

2.3.1 General

1. Sketch plates shall project 3 in. beyond tank walls except on foundation with concrete ringwall.
2. Field erected tanks shall have lapped bottom construction.
3. Vertical and horizontal joints in shell, including top angle-to-shell joint, shall have complete penetration and complete fusion butt welds.
4. Unless otherwise specified on the Tank Data Sheets roof plate joints shall be single-welded full-fillet lap joint construction.
5. The outstanding leg of the top angle on cone roof tanks shall extend inside the tank.
6. Each reinforcing pad, or segments, if more than one piece is used, shall be provided with two ¼ in. diameter NPT threaded "telltale" holes.
7. For heated tanks, the Seller shall furnish calculations to substantiate his basis for vent sizing.
8. Internal coating shall be as specified on Tank Data Sheets.

2.3.2 Tank Venting

Normal and emergency provisions for tank venting shall be provided in accordance with the requirements of API Std 2000. Such provisions shall include at least one free vent with weather hood and without fire snuffer for liquids with a closed cup flash point above 100°F and a

pressure and vacuum vent for liquids with a closed cup flash point of 100°F or less.

### 2.3.3 Basic Allowable Stresses

1. Tanks and their supports shall be designed to resist the effects of storage and wind or earthquake loads within the limits of stress specified herein. Wind and earthquake loads shall not be assumed to occur simultaneously.
2. The basic allowable stresses for design or test conditions shall be the values established by the applicable code. Anchor bolting shall be designed to the allowable tension and shear stresses (without further increase) specified in paragraph 1.5.2 of the AISC "Manual of Steel Construction - Specification for the Design, Fabrication and Erection of Structural Steel for Buildings".

### 2.3.4 Corrosion Protection

1. Corrosion allowance, when specified on the Tank Data Sheets, shall be added to the calculated or minimum specified thickness of all surfaces of the tank, including the roof and other nonremovable parts exposed to the fluid.
2. Corrosion allowance on removable internal parts, unless otherwise specified on the Tank Data Sheets, shall be one-half of the allowance specified on the Tank Data Sheets. This allowance shall be added to all surfaces of removable parts which are exposed to the action of the fluid in the tank.
3. Parts of surfaces which are fabricated of, or surface protected with, corrosion resistant material shall not require corrosion allowance.

### 2.3.5 Ladders, Stairways, Walkways and Handrails

1. Structural steel design shall conform to the requirements of the AISC "Manual of Steel Construction-Specification for the Design, Fabrication and Erection of Structural Steel for Buildings".
2. A tank designed to API Std 650 requirements and not exceeding 20 ft. in height shall be provided with a ladder without a safety cage.
3. An API Std 650 tank over 20 ft. in height shall be provided with spiral stairway (except tank with open roof).
4. A tank designed to ANSI/AWWA D100 standard requirements and not exceeding 20 ft. in height shall be provided with a ladder without a safety cage. Ladders that extend more than 20 ft. above grade shall be provided with safety cages.
5. Dome roof tanks shall be provided with walkways extending to the center of the roof for the maintenance of roof mounted accessories.
6. On cone roof tanks handrails shall be provided on stairways, and near ladders and stairway landings. Handrails shall extend 6 ft. on each side of the working area on tank roofs with a right angle corner extension at each open end.

7. On dome roof tanks handrailing shall extend on both sides of the roof walkway and completely around the working area at the center.
8. In addition to the requirements of tank design code, fixed ladders and cages, railings and toe boards, etc., shall meet the safety requirements of ANSI A12.1, A14.3, A64.1 and the applicable OSHA requirements.

#### 2.3.6 Supports and Foundations

Tank shall be placed a minimum of one (1) ft. above grade on a compacted sand fill. When required by site conditions, tanks shall be supported on concrete ring walls and compacted sand fill. Compacted sand fills under tank bottoms shall extend at least three (3) ft. beyond tank shells and the exposed surfaces outside of tank bottoms shall be protected from erosion by a layer of asphalt emulsion. The tank Seller shall provide foundation loads and anchor bolt requirements.

#### 2.4 Materials and Fabrication

1. All materials and fabrication shall be in accordance with the requirements of the applicable code. Alternative materials will not be permitted without the written consent of the Purchaser.
2. When stainless steel materials are required for special services, they will be specified on the Tank Data Sheets. Code construction only is required, code marking and certification are not required.
3. The Seller shall furnish the following: cover plates, gaskets and bolting for blind flanges, manholes and all other connections so indicated on the Tank Data Sheets as requiring closures. Bolting and gaskets for internal flanges and all test blanks, gaskets and bolting necessary for field tests.
4. Care shall be taken in the storage and handling of weld filler wire to protect them from oxide, moisture or oil films.
5. Except as provided below, products which contain asbestos are prohibited. This prohibition includes items such as packings and gaskets even though the item is encapsulated or the asbestos fibers are impregnated with binder material.

Asbestos products are acceptable only in exceptional cases where the Contractor states in writing that no suitable substitute material exists, and, in addition, the Contractor furnishes to the Engineers a copy of U.S. Department of Labor "Material Safety Data Sheet", OSHA Form Number 20 completed by the asbestos product manufacturer stating that the product is not an asbestos health hazard.

6. Asphalt emulsion shall be furnished in accordance with the requirements of the Asphalt Institute "Specification for Rapid-Curing (RC) Liquid Asphalts" Grade RC-250 and shall be spread at a rate of one-half gallon per square yard.
7. Plate misalignment shall not be corrected by grinding off plate thickness to reduce offset.

8. A maximum of shop fabrication is desired. Field fabrication or assembly shall be limited to only those parts found to be too large for shipment.
9. All clips and attachment shall preferably be welded to the section in the shop, prior to shipping.
10. All openings located six (6) in. or more from any field seam are to be cut out in shop and connections welded in place.
11. Tank shall be completely shop fit-up prior to shipment. Each course shall be fitted and match marked to the adjacent course, rather than assembling entire tank.
12. All clips and attachments which are to be welded in the field shall have their locations marked on the tank sections in the shop.
13. After complete fabrication, the inside of tank shall be thoroughly cleaned. Loose mill scale, droppings and debris shall be removed.
14. Anchor bolting shall conform to the requirements of ASTM A307, grade B.

## 2.5 Connections and Attachments

1. The number of nozzles and manholes, sizes and ratings shall be as shown on the Tank Data Sheets.
2. Nozzle flanges shall be in accordance with ANSI B16.5. Nozzle (or Manhole) projections shall be specified on the Tank Data Sheets. All butt weld end connections shall project a minimum of 6 in. from the outside of the tank unless specifically noted otherwise on the Tank Data Sheets.
3. Threaded type flanges shall not be used.
4. Socket-welding connections shall be in accordance with ANSI B16.11.
5. Threaded connections shall be 3,000 lb forged couplings.
6. All nozzle and manhole joints in tank shells, including bottoms and roofs, shall have complete penetration and complete fusion butt welds.
7. Seller shall design, furnish and install ladder, stairway and walkway clips, pipe supports and pipe guides, lifting lugs, etc. Location, orientation and any pertinent requirements will be furnished by the Purchaser on Seller's fabrication drawings.
8. Insulation and fireproofing supports (studs, nuts, insulation and flashing rings, etc.) shall be designed, furnished and installed by others unless otherwise called for on the Tank Data Sheets.
9. All necessary attachments to the tank or tank sections for shipment and erection shall be furnished by the Seller.
10. Tank anchor clips shall be provided by the Seller. Anchor clips and tank shell shall be designed to withstand wind, earthquake loadings and all other design loads and forces.

11. Internal piping shall be located and supported to provide for necessary expansion and contraction. Internal piping shall be bolted to supports to permit easy replacement. Removable internal parts shall be designed so that they can be withdrawn from the tank through the nearest manhole or opening.
12. The drilling of all flanges or nozzles shall be as follows:
  - a) When nozzle axis is parallel to or coincides with the tank axis, the bolt holes shall straddle the north-south flange center line.
  - b) When the nozzle axis lies in a plane perpendicular to the tank axis, the bolt holes shall straddle the flange center line parallel to the tank axis.
  - c) When the nozzle axis is radial to the tank roof surface, the bolt holes shall straddle the flange centerline lying in the plane containing the tank axis.
  - d) Bolt hole orientation of nozzles not specified above will be shown on the Seller's drawings by the Purchaser.

## 2.6 Tank Design Calculations

If requested in Section 4.8, Project Specific Requirements, the tank Seller shall submit to the Purchaser copies of the Seller's design calculations. Calculations shall be made in sufficient detail to permit independent checking. These calculations will be reviewed and retained in the Purchaser's file. The responsibility for the correctness of these calculations remains with the Seller. Resolution of Purchaser comments on these calculations is required.

## 2.7 Welding

1. All welding procedures and methods shall be consistent with the governing specifications or codes.
2. Welding procedures, welders and welding operators shall be qualified for the material and work involved in accordance with the practice as given in the applicable rules in "Welding Qualifications, Section IX, of ASME Boiler and Pressure Vessel Code," and with the specific requirements of the code specified on the Tank Data sheets; local codes having jurisdiction. Welder's qualifications and procedures shall be submitted before proceeding with fabrication.
3. Examination of the welded joints shall be made as the work progresses in accordance with the applicable code or specification.
4. Chromium-nickel stainless steel material shall not be welded to galvanized steel surfaces.

## 2.8 Dimensional Check

A complete dimensional check of each tank shall be made by the Seller before water fill leak testing of tank shell begins to ensure conformance with the dimensions and orientations specified on the approved Seller's drawings, and to the tolerances required by the code specified on the Tank Data Sheets.

### 3.0 EXAMINATIONS, TESTING, REPAIRS AND INSPECTIONS

Tank shall be examined, tested, repaired and inspected in accordance with the requirements of the code specified on the Tank Data sheets.

#### 3.1 Examinations

1. Examinations of welded joints by removal of sectional segments shall not be used.
2. When complete or spot radiographs are taken at plate junctions, the film shall show at least two (2) in. of weld length on each side of the vertical seam. At least 50 percent of the spot radiographs taken on the vertical seam shall include intersections with a horizontal seam.
3. The inside welds attaching the shell plate to the bottom plate shall be examined by the magnetic particle or liquid penetrant method of examination.
4. Nondestructive examinations (NDE's) shall be performed in accordance with the code requirements specified on the Tank Data Sheets. The Seller shall certify that personnel performing and evaluating NDE's (Radiographic, Magnetic Particle, Liquid Penetrant and Visual Methods) have been qualified and certified in accordance with the Seller's written practice. Recommended Practice No. ASNT-TC-1A shall be used as a guideline for the Seller to establish their written practice for qualification and certification of their personnel. Procedures shall be approved by the Purchaser before examination begins. Personnel qualifications records shall be maintained in the Seller's file.

#### 3.2 Testing

1. Prior to testing, tank shall be thoroughly cleaned of all dirt, weld spatter, loose scale, oil and all other foreign matter.
2. Tank bottom seams and roof seams shall be tested in accordance to the requirements of the code specified on the Tank Data Sheets, and shall be performed prior to water fill leak testing.
3. Each nozzle or shell opening reinforcing pad shall be tested by pressurizing the space between the shell and pad to 15 psig and applying a film of soap-suds solution to the accessible weld surfaces.
4. Each complete tank shall be water fill leak tested following all fabrication or erection operation, with all accessories and appurtenances fully installed, but prior to painting or lining the interior.
5. The tank shall be filled with water and inspected frequently during filling in accordance with code specified on the Tank Data Sheets. The test shall be held for not less than six hours and shall meet the requirements in the code specified on the Tank Data Sheets.
6. Tanks containing solutions with specific gravities greater than 1.0 shall be tested by using a standpipe to produce the equivalent pressure on the tank bottom.

7. Water used for testing shall be not less than 60°F unless otherwise approved by the Purchaser.
8. The water used for field testing a tank will be provided at seasonal ambient temperature by the Purchaser. Tank Seller shall be responsible for any heating of the test water when required.
9. After completion of water leak tests, the Seller shall clean and remove from the inside of the tank all sand, earth, rubbish and debris which may have accumulated during fabrication and testing and shall mop the tank bottom until it is dry. The tank shall be left in a condition acceptable to the Purchaser.
10. Only potable water shall be used for washing or water leak testing tanks or tank parts containing or fabricated from chromium-nickel stainless steel materials.
11. After testing, the Seller shall furnish new and unused gaskets for all manholes, body flanges and other special openings which call for a blind flange or cover.
12. Heating and cooling coils shall be hydrostatically tested at 1½ times the specified design pressure.

### 3.3 Repairs

1. In addition to the defects listed in the code specified on the Tank Data sheets, the following conditions are considered defective and detrimental to the safety and appearance of a tank and shall be repaired or removed: plate laminations, dents and wavy plates or plate edges.
2. All unacceptable defects shall be repaired in accordance with code requirements specified on the Tank Data Sheets. Repaired areas shall be subjected to retesting.
3. When a plate is discovered to have a defective condition during fabrication, all further work on that plate and each adjacent plate shall be stopped until the defective condition is corrected. Water filling or guying shall not be considered adequate repair methods.
4. Welds with defective areas removed shall be rewelded using qualified welding procedures and the repair welds shall be re-examined by the original method for freedom from defects. If correction involves serious alteration, the approval of the purchaser shall be obtained before proceeding with correction.
5. The cost of any repair approved by the Purchaser shall be borne by the Seller if due to defective workmanship, materials, processes, procedures or other conditions.

### 3.4 Inspections

The Purchaser's inspector(s) shall have at all times free entry to all parts of the job while other work under the contract is being performed. The following are hold points for which prior notification may be required:

1. Tank bottom seams and roof seams testing.
2. Nozzle or shell opening reinforcing pad testing.
3. Tank water fill leak testing.

#### 4.0 SUPPLEMENTARY REQUIREMENTS

##### 4.1 Surface Preparation

All ferrous metals shall receive the preparation as required by Attachment 3, Specification SA-550: "Technical Specification for Painting Ferrous Metals Included in Subcontractor's Work."

##### 4.2 Painting

1. Prime painting per Attachment 3, Specification SA-550: "Technical Specification for Painting Ferrous Metals Included in Subcontractor's Work."

##### 4.3 Nameplates

1. Each tank shall be provided with a nameplate permanently attached to the exterior of the tank in an accessible location external to any insulated surface and observable while the tank is in operation and shall meet the requirements of code specified on the Tank Data Sheets. The nameplates shall contain the minimum recommended information required in the code specified on the Tank Data Sheets unless otherwise called for on the Tank Data Sheets.
2. Stainless steel tanks shall contain, with the exception of the official code marking, the minimum recommended information required in the code specified on the Tank Data Sheet unless otherwise noted.

##### 4.4 Drawings and Data

The Purchaser will furnish the Seller with Tank Data Sheets specifying the conditions of design and showing the shape, dimensions and certain constructional details of the tank. The following information will also be furnished as may be required.

1. Plot plans with coordinates showing location of each tank and the working area to be allotted to the Seller for office space, material storage, etc.
2. Foundation sketches.
3. The centerline, the center point and one elevation near the tank site.
4. The maximum water filling rate for field tank testing.
5. Snow load, roof load, wind and earthquake loads, and any other loads required for structural design.
6. Nozzle locations.



After award, the information and data requested in Attachment 2, as a minimum, shall be submitted in accordance with the agreed upon schedule, as noted in Attachment 2.

The following requirements define the drawings and data submittals:

1. Document submittal schedule shall include drawing index listing the number and description of all drawings to be furnished and the proposed issue dates.
2. Welding Procedure Specifications (WPS's) and Procedure Qualification Records (PQR's).
3. Certified detail drawings showing the following:
  - (a) Design data including shipping, erection, operating and full of water weights; nozzles and manholes, etc.
  - (b) Bill of materials.
  - (c) Material specification.
  - (d) Plate layouts, welding details, welding grooves, reinforcing pads, etc.
  - (e) Layout of wind and erection guys.
  - (f) Complete information for the design of the foundation including loadings, elevation, base plate details and the size, location and material specifications of all anchor bolts.
  - (g) The name plate location and facsimile (photograph or pencil rubbing) of required code marking.
  - (h) A tabulation of allowable forces and moments in each plane for nozzle connections, if any, at which piping reactions must be limited.
4. Certified design calculations.
5. Calculation to substantiate the basis of vent sizing for heating tanks.

#### 4.5 Records

The records listed below shall be available for examination by the Purchaser:

1. Mill test reports for primary pressure parts except pipe. Mill test reports shall state the specification to which the material complies, the heat, lot or melt number, the heat treatment (if any) given the material, and the results of chemical analysis and physical tests. Certificates are acceptable for heat treatment information missing on mill test reports.
2. Certificates for pressure and nonpressure part materials obtained from stock

except as required by subparagraph (1), for which mill test reports are not available.

3. Certificates for bolting material.
4. No records are required unless specified by code or material standard for pipe fittings and flanges made in accordance with an acceptable standard such as ANSI nor are they required for pipe marked in accordance with the ASTM material standard. Certificates are required when the markings are missing or are removed during fabrication operations.
5. Welding Qualification Test Reports for welders and welding operators.
6. Radiographic film for required radiographic tests and certificates for the results of any required magnetic particle, fluid penetrant or other methods of examination.
7. Charts or other records of required hydrostatic, pneumatic and other tests.

#### 4.6 Preparation for Shipment

1. Shop fabricated plates, pieces or assemblies shall be loaded for shipment in such a manner to keep damage to plates, pieces, assemblies or appurtenances, at minimum. Written instructions covering the location and stacking limits of the crates or boxes on the transport vehicle shall be specified. These should be marked on the container.
2. The weight, lifting points, or center of gravity indicated on the crate, skid or package shall be utilized for all handling procedures.
3. Service gaskets for manhole and blind flange covers, spare parts, etc., shall be boxed or crated to prevent damage in shipment. Prior to shipment boxes or crates shall be marked to indicate the contents and show purchase order and the tank item numbers.
4. It is expected that any shipments made to the job site will be stored outdoors. Therefore any special storage requirements specified by the Seller shall be forwarded to the job site with each shipment to which they are applicable.

#### 4.7 Schedule

For all equipment provided as part of this purchase order, the Schedule, or revisions to it, as submitted to the Purchaser and agreed upon by the Seller and the Purchaser before the purchase order is placed and included with the purchase order, shall be binding on the Seller. The Seller shall submit any requested changes to the schedule to the Purchaser for approval.

#### 4.8 Project Specific Requirements

The attached Project Specific Requirements, if any, are additions, deletions and/or revisions to the preceding specifications and shall be considered as part of this specification.

ATTACHMENT 1  
TANK DATA SHEET  
DEMINERALIZED WATER STORAGE TANK  
QUANTITY OF TANKS REQUIRED ONE (1)

ITEM	
Design Conditions	
Tank Drawing Number:	SKM 120
Design Temperature, °F:	120 °F
Design Pressure, psig:	ATM
Full Vacuum Design:	<input type="checkbox"/> Required <span style="float: right;"><input checked="" type="checkbox"/> Not Required</span>
Type:	<input checked="" type="checkbox"/> Vertical <span style="float: right;"><input type="checkbox"/> Horizontal</span>
OD, ft-in:	20'-0" ID
Height, ft-in	24'-0" Straight Sidewall'
Design Capacity, gal:	50,000 Gallons
Contained Fluid:	Demineralized Water
Operating Temperature, °F:	40°F – 100°F
Operating Pressure, psig:	Atmospheric
Corrosion Allowance	Not Required
Tank Location:	<input type="checkbox"/> Indoor <span style="float: right;"><input checked="" type="checkbox"/> Outdoor</span>
Maximum Fill Rate	150 gpm
Maximum Emptying Rate	150 gpm
Ambient Conditions:	
Pressure, psig:	23 Feet above mean sea level
Temperature, °F:	Min 40°F    Max 100°F
Humidity, %:	Norm 75    Max 100
Loading Criteria:	
In accordance with Florida Building Code (2001):	<b>130</b> (SEE ATTACHMENT 4)
Basic Wind Speed	<del>120</del> mph
Live Load	A minimum uniform live load of 20 psf shall be applied to the roof structure
Snow Load	None
Seismic Load:	Very Low
Materials of Construction:	Carbon Steel
Ladders and Platforms:	<input checked="" type="checkbox"/> Required <span style="float: right;"><input type="checkbox"/> Not Required</span>
Internal Piping:	<input checked="" type="checkbox"/> Required <span style="float: right;"><input type="checkbox"/> Not Required</span>
Remarks and Special Requirements:	
<ul style="list-style-type: none"> <li>• Tank shall be provided with caged ladder to access top of tank.</li> <li>• Tank Lining <span style="float: right;">Plasite 7156</span></li> <li>• Tank Design Code <span style="float: right;">ANSI/AWWA D-100</span></li> <li>• Furnish gooseneck vent with 1/4" SS mesh bird screen</li> <li>• Tank Exterior Coating <span style="float: right;">Prime Paint Per Spec SA-550</span></li> <li>• Furnish Two (2) Shell Manways and One (1) Roof Manway</li> <li>• Tank foundation will be reinforced concrete mat foundation</li> </ul>	
Legend: NA = Not Applicable	X = Required

PROJECT SPECIFIC REQUIREMENTS FOR FIELD FABRICATED STEEL TANKS

Section 1.2.1a) Revise as follows:

"The cost of furnishing all tank appurtenances and accessories specified herein and on the Tank Data Sheets and as shown on Tank Drawing SKM120."

Section 2.1 Referenced Codes, Standards and Other Documents

Add the following Codes:

Florida Building Code (2001)

Section 2.3.6 Tank will be placed on a reinforced concrete mat foundation

Section 2.4.5 Delete 2<sup>nd</sup> paragraph. Asbestos products are not allowed.

Add Section 2.9 "Tank Lining"

2.9 Tank Lining

1. Demineralized storage tank shall be lined with Plasite 7156 or Purchaser approved equal epoxy phenolic coating.
2. Lining shall be applied in accordance with the lining manufacturer's recommendations.
3. Lining shall include all interior surfaces of the tank, all exposed steel surfaces inside the tank, all nozzles out to and including the exterior face of all nozzle flanges where piping or manway covers have been removed and the surface of all manway covers exposed to the inside of the tank.
4. The completed lining shall be tested by the Tank Manufacturer. The lining shall be checked for pinholes, holidays, and bare areas with a Tinkor Razor Model APW Spark Tester or equivalent at a minimum of 1500 volts. Any pinholes shall be removed by grinding out the coating area to the shell plate, followed by an inspection to assure the appropriate surface profile exists before re-application of the coating. Repairs shall be in accordance with the lining manufacturer's recommendations.

5. The words "DO NOT WELD - LINED TANK" shall be stenciled on the outside of lined tanks. The words shall be visible from all sides of the tank.

Add Section 2.10 "Tank Materials of Construction"

Shell	A36
Roof	A36
Tank Bottom	A36

Section 2.4, Add the following paragraph:

Each tank shall be provided with three (3) grounding pads equally spaced around the exterior of the tank, and 6 inches above the bottom. Grounding pads shall be Type 304 stainless steel and shall be welded to the tank.

Option: Seller shall provide an option price for a tank of all stainless steel construction in lieu of the specified coated carbon steel tank.

ATTACHMENT 2

DOCUMENTS SUBMITTAL SCHEDULE

<u>Documents for Approval</u>	<u>Purchaser Need Date*</u>	<u>Schedule Date for Certified Seller Submittal**</u>
Document Submittal Schedule	<u>10</u>	<u>30</u>
Welding Procedures	<u>30</u>	<u>30</u>
Equipment Outline Drawings	<u>30</u>	<u>30</u>
Equipment Loading Diagrams	<u>30</u>	<u>30</u>
Certified Detail Drawings	<u>60</u>	<u>30</u>
Certified Design Calculations	<u>60</u>	<u>30</u>
 <u>Documents for Information</u>		
Fabrication and Erection Drawings	<u>120 days before shipment</u>	<u>30</u>
Storage and Handling Procedures	<u>60 days before shipment</u>	<u>NA</u>
Test Program Procedure	<u>60 days before shipment</u>	<u>30</u>
Priced Spare Parts List (if any)	<u>At the time of Purchase Order</u>	

\*Calendar days after award

\*\*To be completed by Seller and finalized prior to award

MANHOLE AND NOZZLE TABULATION

MARK	DESCRIPTION	NO. REQ'D	SIZE (IN.)	TYPE	RATING
A	LADDER	1	SPEC.	CAGED	
B	MANWAY	3	24		
C					
D	FILL LINE	1	2 1/2	FLGRF	150#
E	PUMP SUCIION	1	6	FLGRF	150#
F	VENT WITH 180° RETURN BEND (NOTE 1)	1	6	FLGRF	150#
G	OVERFLOW	1	6	FLGRF	150#
H	PUMP RECIRC.	1	2	FLGRF	150#
J	LEVEL INSTR.	2	1	THREADED	150#
K	DRAIN	1	3	FLGRF	150#
	SPARE NOZZLES (SHELL) FURNISH WITH GASKETS AND BLIND FLANGES	1	6	FLGRF	
		1	3	FLGRF	
		2	1	THREADED	

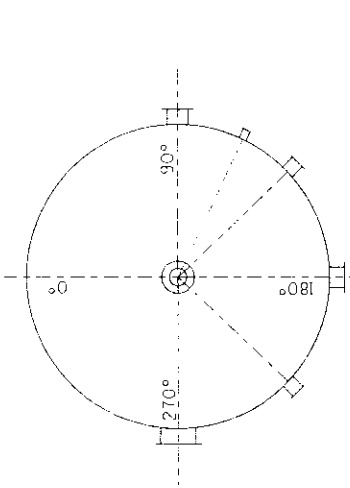

ORIENTATION PLAN

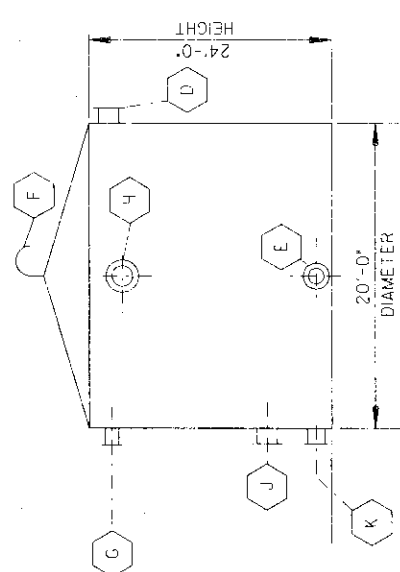

ELEVATION

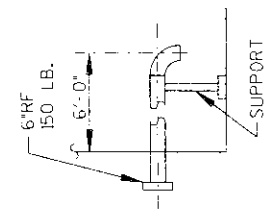

DETAIL OF E

LEGEND

- BUTT WELD
- FLANGED-FLAT FACE
- FLANGED-RAISED FACE
- SCREWED
- SOCKET WELD
- BTWLD
- F-GFF
- FLGRF
- SCRD
- SKT WLD

TANK ROOF

- CONE
- DOME
- UMBRELLA (OPTION)

NOTES

1. PROVIDE 1/4" SS MESH BIRD SCREEN FOR TANK VENT.
2. NOZZLES H, D AND E SHALL HAVE INTERNAL SS (304) PIPING, WELDED.
3. NOZZLE PROJECTION IS 6" FOR ALL NOZZLES.
4. FLANGES DRILLED PER ASME/ANSI B16.5.
5. MANWAYS SHALL BE PROVIDED WITH 1/2" NEOPRENE GASKET AND ZINC PLATED STEEL NUTS & BOLTS.
6. FINAL NOZZLE LOCATIONS WILL BE PROVIDED BY BRF ON THE TANK CONTRACTOR'S DRAWINGS.
7. NOZZLE PROTECTIONS WILL BE PROVIDED LATER.

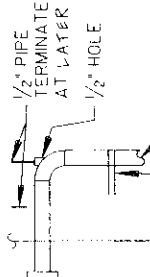

DETAIL OF H & D

Drawing Control		STATUS: 11-30-04	
Purpose	Approved By	Date	Released By
For Information			
For Comment			
For Bid			
For Fabrication			
For Construction			

LEE COUNTY WTE PLANT UNIT 3 EXPANSION PROJECT  
SOUTHWEST FLORIDA  
BOARD OF COUNTY COMMISSIONERS

DEMINERALIZED WATER STORAGE TANK  
DW-TK-001

**BR** BURNS AND ROE ENTERPRISES, INC.  
Engineers and Constructors - Oradell, NJ

Approved for Construction Work Order: 2661  
Chief MECHANICAL Engineer

Drawing No: SKM120  
Sh: A

COVANTA ENERGY

SPEC. NO. SA-550  
ISSUE 004  
DATE 07/16/01

TECHNICAL SPECIFICATION  
FOR  
PAINTING FERROUS METAL  
INCLUDED IN SUBCONTRACTORS WORK

Facility Name: LEE COUNTY WTE EXPANSION

Location: FORT MYERS, FLORIDA

\*\*\*\*\*

This document and all information contained  
herein are the property of Covanta  
Lee County and are not  
to be used except as expressly authorized in  
writing by said company

\*\*\*\*\*

Specification Prepared By: A/E Name: Burns and Roe, Enterprises, Inc.  
Address: 800 Kinderkamack Road  
Oradell, New Jersey 07649  
Telephone: 201-265-2000

A/E Approved for Release:

1.	<u>M. PATEL</u> Printed Name	<u>M. Patel</u> Signature	<u>11-17-04</u> Date
2.	_____	_____	_____
3.	_____	_____	_____
4.	_____	_____	_____
5.	_____	_____	_____



REVISIONS

001	Initial Issue.....	.08/16/89
002	Revision.....	.08/15/90
003	Revision.....	.01/12/00
004	Revision.....	.07/16/01

TECHNICAL SPECIFICATION  
FOR  
PAINTING FERROUS METALS  
INCLUDED IN SUBCONTRACTOR S WORK

TABLE OF CONTENTS

<u>SECTION</u>	<u>TITLE</u>	<u>PAGE</u>
1.0	GENERAL	1
1.1	Scope	1
1.1.1	Work Included	1
1.2	Related Work	1
1.3	References	2
1.3.1	Abbreviations	
1.3.2	Codes and Standards	2
1.4	Quality Assurance	2
1.5	Submittals	2
1.6	Product Shipping, Handling and Storage	3
1.7	Scheduling	3
1.8	Safety	3
2.0	PRODUCTS	3
2.1	Acceptable Manufacturers	3
2.2	Materials	4
3.0	EXECUTION	4
3.1	Coordination	4
3.2	Job Conditions	5
3.2.1	Atmospheric Conditions	5
3.2.2	Fire Protection	5
3.3	Color Section	5
3.4	Protection of Adjacent Surfaces	5
3.5	Surface Preparation	6
3.6	Mixing	6
3.7	Application	6
3.8	Testing of Materials	7
3.9	Inspection	7
3.10	Touch-Up	8
3.11	Clean-Up	8
3.12	Paint System	8
3.13	Project Specific Requirements	8
ATTACHMENT 1	Document Submittal Schedule	A1 - 1

## 1.0 General

### 1.1 Scope

This Specification establishes the minimum requirements for the furnishing of all labor, materials, tools and equipment, the coordination of work with that of other trades, and the performing of services for the coating of ferrous metals as shown on the plans and specified herein, including both shop and field applied systems. This Specification shall be worked with Specification SA-502, Painting. Reference to other industry standards for compliance shall be interpreted as an integral part of this Specification.

#### 1.1.1 Work Included

Work shall include but is not limited to the surface preparation and application of prime and finish coats and touch-up of paint systems on ferrous metals. Items receiving coatings shall include but are not limited to:

- Structural Steel
- Miscellaneous steel angles, channel, plates, braces, brackets, embedment, etc.
- Equipment Supports
- Ducts as required
- Pipes
- Stair stringers and pans
- Handrails and Guardrails
- Hollow metal doors and frames, and industrial doors
- Electrical cabinets
- Louvers
- Equipment furnished without shop finish

### 1.2 Related Work

Items of work related to work of this Specification, but not included within its scope shall be furnished or performed under the General Contractor's responsibilities. These items include, but are not limited to:

- Shop finished equipment
- Removal and reinstallation of fixtures, equipment and systems by others when required

Other specifications related to work in this Specification include but are not limited to the following:

SA-502      Painting

### 1.3 References

#### 1.3.1 Abbreviations

Abbreviations listed below, when used in this Specification, shall have the following meanings:

ANSI	American National Standards Institute
CFR	Code of Federal Regulations
SSPC	Steel Structures Painting Council

#### 1.3.2 Codes and Standards

Work under this specification shall be performed in accordance with applicable sections of the following codes, standards, publications and practices, and to the extent referenced, form a part of this specification. Date of issue in effect at the time of Notice to Proceed shall apply.

ANSI A13.1	Scheme for the identification of piping systems
29 CFR 1910 & 1926	Occupational Safety and Health Act (OSHA)
SSPC-SP-1	Solvent Cleaning
SSPC-SP-3	Power Tool Cleaning
SSPC-SP-6	Commercial Blast Cleaning

### 1.4 Quality Assurances

All stages of work including surface preparation, priming and finish coating of surfaces, materials, equipment, workmanship, and touch-up shall be subject to inspection by a representative of Purchaser for conformance to the applicable SSPC specifications, the manufacturer's instructions, and this specification.

All components of each paint system, specified herein, shall be by one manufacturer. The paints of one manufacturer shall not be used over the paint of another and shall not be intermixed with each other unless approved by Covanta.

### 1.5 Submittals

In compliance with all provisions and conditions of the Contract, the following items and documents shall be submitted per the document submittal schedule in Attachment 1.

#### 1.5.1 Engineering Documents

- Technical data sheets on each product to be used.
- A paint schedule indicating the total system (material, thickness, etc) to be applied including surface preparation for each substrate type.

- Color selection charts with the full range of manufacturer's standard colors for selection by Purchaser.
- Material Safety Data Sheets for coatings, solvents, etc.
- Manufacturer's instructions for mixing, thinning, application and storage of the coating materials

### 1.5.2 Verification Documents

Written Certification that all coatings comply with the provisions of this specification. Alternate manufacturer's will only be considered upon submittal of complete technical and company data and approval by Purchaser.

### 1.6 Product Shipping, Handling and Storage

All coating materials shall be delivered to the job site in original, sealed and unopened containers bearing the Manufacturer's name, paint type designation, batch number, color and shelf life.

Coatings shall be stored in an area that is well ventilated and free from excessive heat, sparks, flame or the direct rays of the sun. Ambient temperature of storage areas shall be maintained within the range specified in the coating manufacturer's printed instructions unless otherwise specified.

### 1.7 Scheduling

It shall be the responsibility of the contractor to provide schedules for the painting of surfaces and to coordinate the coating work with the work of all other trades.

### 1.8 Safety

The Contractor shall observe all OSHA, state and local laws, ordinances and regulations pertaining to health and safety. The precautions indicated on the paint containers with regard to fire and safety, as well as the laws of the state in which the project is located, shall be observed.

## 2.0 Products

### 2.1 Acceptable Manufacturers

Subject to compliance with this specification and the painting schedule herein, the following coating manufacturers are acceptable to provide the materials for the work:

- (a) Carboline Company
- (b) Cook Paint and Varnish
- (c) Glidden
- (d) Hempel's Industrial Coatings
- (e) Keeler and Long
- (f) Pratt and Lambert
- (g) Sherwin/Williams Company
- (h) Tnemec

The above manufacturer's provide the quality of paint, and are of the stature to provide the specified coatings for this project. The brand names and designations used in the specified Paint systems indicate the required type and quality of the coating to be furnished.

## 2.2 Materials

Materials supplied shall be per the Paint Systems as listed in section 3.12. When required, all coatings shall be mixed in strict accordance with the manufacturer's written instructions, and thinning shall not be permitted unless specified in those instructions. Thickness of coatings shall comply with manufacturer's recommendations. Where a range of thickness is presented in the technical data, the thicker coat shall be applied.

All tools and equipment necessary for surface preparation and application of coatings such as compressors, spray equipment, sandblaster, power tools, brushes, etc., shall be maintained in good working order.

Any false work (scaffolding, ladders, etc.) required for surface preparation and/or painting shall be designed by the Contractor for loads not less than those established by the state or local building codes and (OSHA) 29 CFR 1910 and 29 CFR 1926. The cable trays, conduit, piping, etc, shall not be used for support or access unless prior approval is obtained from Covanta.

## 3.0 Execution

### 3.1 Coordination

It shall be the responsibility of the Contractor to coordinate with all material and equipment suppliers furnishing items that are to be shop primed and field finished in order to ensure compatibility of the prime and finish coats. It is imperative that the paint systems specified herein be followed.

## 3.2 Job Conditions

### 3.2.1 Atmospheric Conditions

Paint shall not be applied when the surfaces are at a temperature of over 120 F unless the paint is specifically formulated for application at elevated temperatures. When painting in hot weather, precautions shall be taken to assure that the specified dry film thickness (DFT) of paint is obtained.

Paint shall not be applied in rain, snow, fog or mist, or when the relative humidity is such as to cause condensation on surfaces. All surfaces shall be completely dry before, and while being painted.

Forced ventilation shall be provided to keep fume levels at safe levels and shall be exhausted outdoors. Spark producing motors or implements shall not be used in areas when fume concentrations may occur.

### 3.2.2 Fire Protection

Oily rags and other waste which may constitute a fire hazard, shall be removed daily or stored in U.L. labeled metal containers with automatic closing covers.

The Contractor shall provide portable fire extinguishers of suitable type and sufficient number to permit placing at least one (1) extinguisher in any area where coating with fume-creating or flammable products is in progress, and where coatings are stored and mixed. No smoking shall be permitted in these areas and the Contractor shall be responsible for policing the work.

## 3.3 Color Selection

With the exception of standard colors for pipe identification or designated safety hazards, the colors will be selected specifically for this project and shall be presented separately in a color schedule.

Regardless of the source utilized in the selection of colors for the Project, the Contractor shall be responsible for assuring that all finish paints match the specified colors. If required, the Contractor shall submit samples of the specified color and the color selected by the Contractor to the Purchaser for color match analysis.

## 3.4 Protection of Adjacent Surfaces

All hardware, hardware accessories, machined surfaces, nameplates, lighting fixtures and similar items on or in contact with surfaces to be painted shall be removed, masked or otherwise protected prior to surface preparation and painting operations. All protective covers shall be removed upon completion of paint application.

### 3.5 Surface Preparation

Surfaces shall be prepared for coating in accordance with SSPC specifications and preparation technique for each surface shall be indicated in the painting schedule by the Contractor.

The anchor profile provided on steel shall be not less than that specified by SSPC-SP-6.

After blast cleaning, dust, loose particles and spent abrasives shall be removed from the prepared surfaces by compressed air or vacuum cleaning, and the cleaned surfaces shall be primed as soon as possible after blasting and always before surface starts to rust. Cleaned surfaces shall not be allowed to stand overnight before coating.

Where applicable, dirt, dust, oil, grease and similar contaminants shall be removed by solvent cleaning in accordance with SSPC-SP-1.

### 3.6 Mixing

All ingredients shall be thoroughly mixed before use and agitated frequently during application to keep the paint in suspension. Mechanical mixers and agitated pressure pots shall be used as required.

Paints shall be thinned only when necessary for good application properties, and only with the recommended thinner, in amounts recommended by the paint manufacturer.

Catalysts or other types of multipackaged paints shall be mixed in strict accordance with manufacturer's recommendations and instructions.

### 3.7 Application

In general, the Manufacturer's specifications regarding the mixing, thinning, application, drying and general handling of the various materials shall be followed as being supplementary to this Specification.

Spray application may be used at the Contractor's option in non-enclosed areas when the spraying can be closely controlled to prevent spattering any other property.

Effective oil and water separators shall be used in all compressed air lines to remove oil or moisture from the air before it is used. Separators shall be placed as close as practical to the equipment. The effectiveness of the separators shall be tested by means of the "white blotter test". The test shall be performed prior to blasting or spray coating, and at intervals of four (4) hours during the work. Tests shall be at full operating pressure and velocity.

Nozzle sizes and pressure settings for spray equipment shall comply with the manufacturer's recommendations.



When coatings are applied by spraying, each coat shall be sprayed in two directions at right angles to each other, to obtain complete coverage. Care shall be exercised during spraying to avoid excessive evaporation of the volatile constituents, loss of material into the air, and the bridging over of crevices and corners.

Areas inaccessible to the spray gun shall be coated by brush and if not accessible by brush, daubers or sheepskins. Brushes shall be used to work coating into cracks, crevices, and blind spots which cannot be adequately coated by spray.

When coatings are applied by brush or roller, the surface shall be cross-brushed or cross-rolled to secure uniformity of surface and the specified paint film thickness.

Film thickness of the coating being applied shall be periodically checked using a wet film thickness gauge. Dry film thickness shall be calculated from wet film thickness and volume solids and as recommended by the Coating Manufacturer. In addition, each coat shall be visually inspected for holidays and thin spots before the next coat is applied.

Steel which has been coated shall not be handled, worked on, or otherwise disturbed until the coating is completely set. Sufficient time shall elapse between coats to permit them to dry hard. All coats of coated surfaces shall be unscarred and completely integral at the time of application of all succeeding coats.

Prior to application of the finish coat, all visible rust resulting from construction damage, or other coating or surface defects, shall be removed and the surface prepared to the requirements of SSPC-SP3 Power Tool Cleaning and the prepared surface re-primed per Purchaser approved repair procedure.

### 3.8 Testing of Materials

The dry film thickness (dft) of non-metallic paints applied to magnetic surfaces shall be measured nondestructively using the "Elcometer" thickness gauge, as marketed by Gardner Laboratories, or similar magnetically operated testers. Non-metallic paints applied to nonmagnetic surfaces shall be measured using a battery powered, penetrating - needle type thickness gauge such as the "Gardner Thickness Gauge", also marketed by Gardner Laboratories.

### 3.9 Inspection

All work performed under this Contract shall be subject to inspection by Purchaser.

All deficiencies, defects and damage revealed by the inspection and caused by test methods used shall be promptly repaired or corrected, using the applicable type, grade and color of finish coat material, and preparation methods.

Any part of the paint system which is defective shall be corrected. The method of repairing damaged areas shall be in accordance with the requirements listed for the original system. Damage to adjacent systems painted by other shall be corrected in the same manner. Field touch-up of shop primer shall be with the same paint as the original primer.

### 3.10 Touch-Up

All shop-primed and shop-topcoated steel shall be touched up in the field as required, prior to final field, topcoating. Touch-up shall include any damaged or masked areas.

Field touchup shall be done after final erection or assembly, unless otherwise specified.

### 3.11 Clean-Up

All surfaces not coated under this specification, or those previously coated, shall be carefully protected during coating work.

Any unspecified coatings which are found during inspection shall be thoroughly cleaned and the original finish restored at the Contractor's expense.

Name and data plates on equipment shall not be painted and shall be left clean and legible upon completion of the project.

### 3.12 Paint System

The paint system descriptions provided herewith outline the generic paint system names. The paint system numbers are then utilized in the approved coating Manufacturer's system schedule and the Application Schedule to dictate the coating system for each type of substrate.

Ferrous Metal:	Prep:	SSPC-SP-6
	Prime:	Recoatable Polyamide Epoxy
	Topcoat:	Hi Solids Polyurethane

Examples of Approved System:	Mfgr. - Sherwin Williams
	Prime: B67H5/B67V5
	Topcoat: B65 - 300 Series

### 3.13 Project-Specific Requirements

The attached Project Specific Requirements, if any, are additions, deletions and/or revisions to the requirements of this Specification and shall be considered a part of this Specification.

ATTACHMENT 1

DOCUMENTS SUBMITTAL SCHEDULE

<u>Documents for Approval</u>	<u>Engineering Need Date For Vendor Data*</u>	<u>Schedule Date For Certified Vendor Submittal **</u>
A. <u>Technical Data Sheets</u>	30	
<u>Color Charts</u>	30	
<u>Paint Schedule</u>	30	
<u>Mixing/Application Inst.</u>	30	
B. <u>Documents for Information</u>		
<u>Certificate of Compliance</u>	45	
<u>Material Safety Data Sheets</u>	30	

\*Calendar days after award

\*\*To be completed by seller and finalized prior to award

SPEC NO. SS-550  
ISSUE 004  
DATE 07/16/01

LEE COUNTY WASTE TO ENERGY EXPANSION PROJECT

ATTACHMENT 2

PROJECT SPECIFIC REQUIREMENTS

1. Under 3.12 Paint System

Delete paint and example of approved system and substitute the following:

Ferrous Metal:

Prep: SSPC-SP6  
Primer: Carboline Carbozinc 859 (applied at 4 mil dry film thickness)  
Topcoat: Carboline 133 HB - Polyurethane (applied at 4 mil dry film thickness)

If topcoat is applied in the shop, slip-critical connection contact surfaces shall be properly classified or connection areas shall be masked to achieve class B contact surface. Paint substitution shall be equal in all respect and it will require written approval of Covanta.

Paint for the hot surfaces shall be selected by Contractor and subject to approval by Covanta

*Attachment 4  
Wind Design Information*

**Detail Specification**

Revise the following in Attachment 1 – Design Conditions and Project Specific Requirements:

Wind: 130 mph (Located Outside the Wind-Borne Debris Region)  
Importance Factor  $I_w = 1.00$   
Exposure C.

Code: It is anticipated that the 2004 Florida Building Code will be in effect on July 1, 2005. The 2004 Florida Building Code is based on the 2003 International Building Code, with Florida amendments. A draft copy of the 2004 Florida Building Code is available on the web at [www.floridabuilding.org](http://www.floridabuilding.org).

It is required that the Project comply with the Florida Building Code in effect on the date of construction permit application. It is anticipated that the construction permit application will be submitted after July 2005.

In the event that the 2004 Florida Building Code is not adopted (put in effect) prior to submission of the construction permit application, the project design must comply with current 2001 Florida Building Code.

Based on the above, Contractor's design shall comply with the more stringent requirements specified in the 2001 or the 2004 Florida Building Code.

Revised January 31, 2005

## ATTACHMENT 5

Field Fabricated Tank  
Specification SM-141  
**Addendum**

There is an existing 138 kV live overhead transmission line running just east of the field fabricated Demin Water Tank. Transmission line is located within the corridor shown on attached sketch SK-001. Attached photo show the approximate relation between transmission line and tank. Transmission line will remain energized at all times. Contractor shall investigate and determine available horizontal and vertical clearances for its equipment passing, or operating, under or adjacent to the existing structures and overhead lines in the Work area. Contractor shall comply with Covanta's requirements for operating equipment on the site, and Florida Power and Lights requirements for required clearances from the 138 kV transmission line.

~~ATT-8~~  
~~3-9-14~~

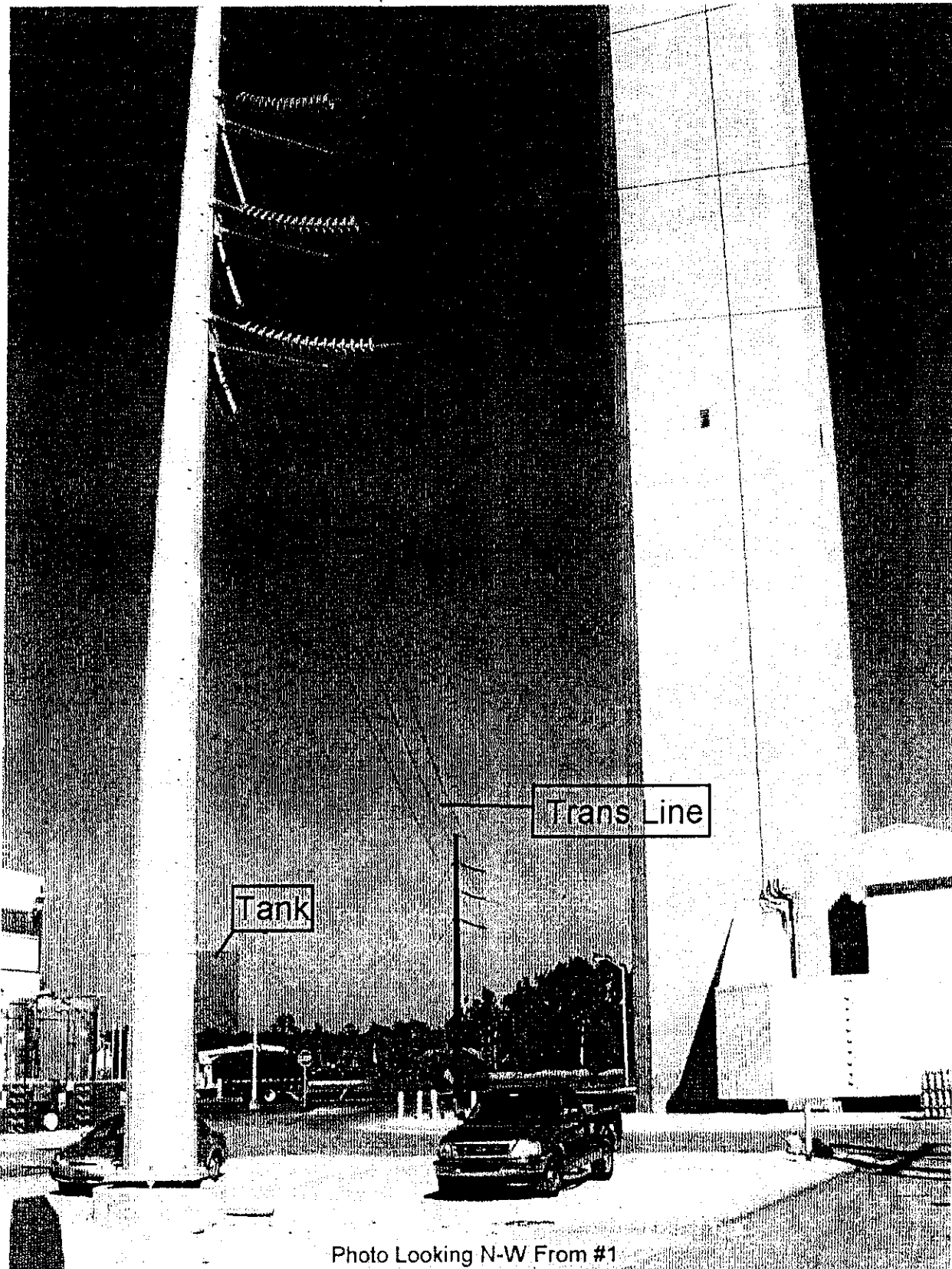

Photo Looking N-W From #1

7

6



LEE COUNTY WTE PLANT EXPANSION  
DETAIL PLOT PLAN  
DWG C012

REVISED LOCATION OF DEMIN  
WATER TANK

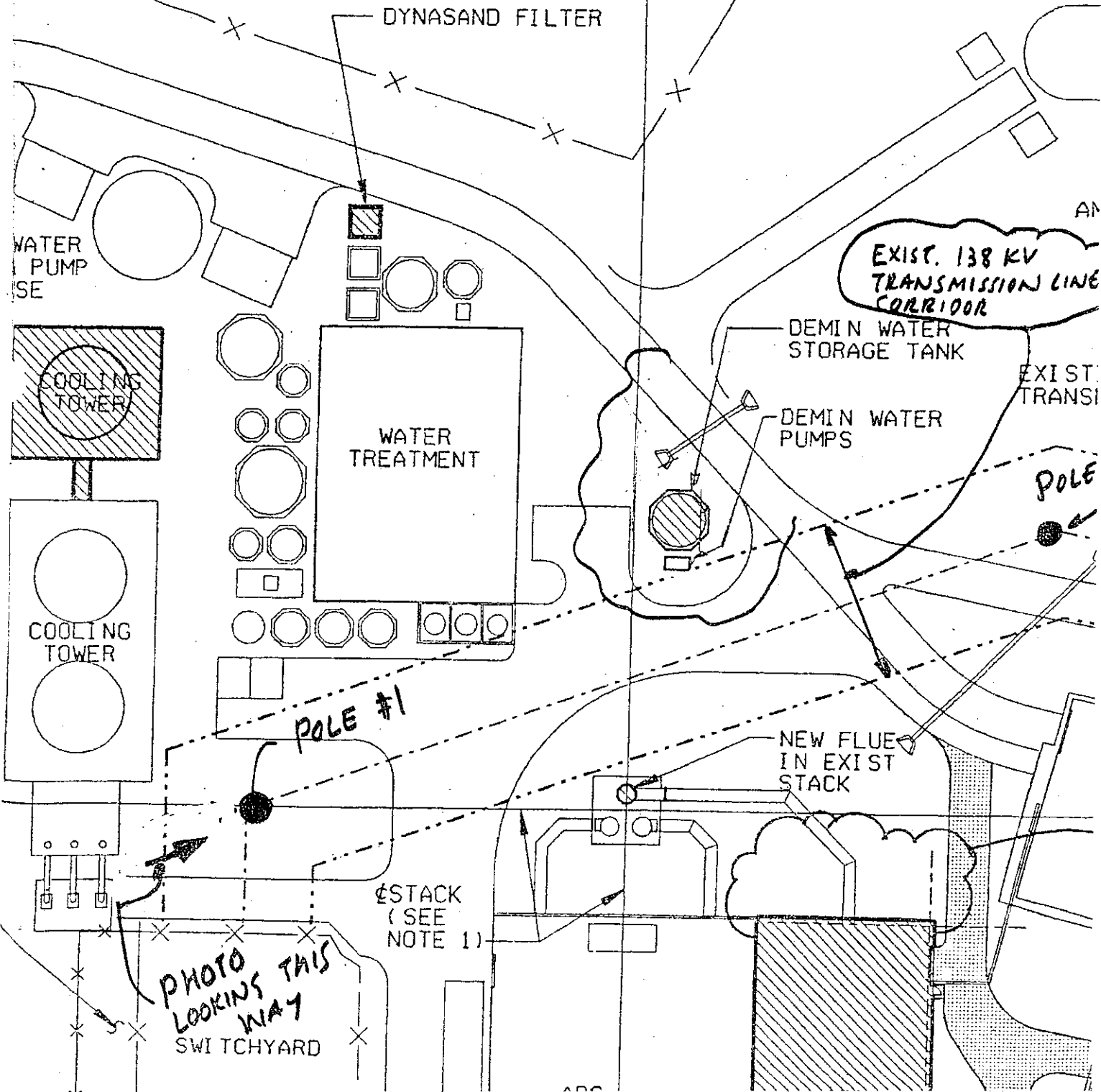

DYNASAND FILTER

WATER  
PUMP  
USE

COOLING  
TOWER

WATER  
TREATMENT

COOLING  
TOWER

DEMIN WATER  
STORAGE TANK

DEMIN WATER  
PUMPS

EXIST. 138 KV  
TRANSMISSION LINE  
CORRIDOR

EXIST.  
TRANSI

POLE

POLE #1

NEW FLUE  
IN EXIST  
STACK

ESTACK  
(SEE  
NOTE 1)

PHOTO  
LOOKING THIS  
WAY  
SWITCHYARD

PI

AM

APP



**EXHIBIT C**

**PAYMENT PROCEDURES**

**The following are the Contract payment terms based upon achievement of the following milestones:**

**-\$1,500. upon submittal of 100% Performance and Payment Bond**

**-\$3,500 upon submittal and approval of Contractor drawing**

**-Remainging Contract Price to be paid in accordance with Contract Article**

**4.2.**

**EXHIBIT D**

**PROJECT and CONTRACT SCHEDULE**

Contractor shall furnish all services necessary in the performance of the Work as required by the Contract Documents.

The Master Project Schedule drawing number LeeexpanMPS, rev. 2 is attached to this Contract and made part hereof by this reference.

The Contract schedule is as follows:

<u>EVENT</u>	<u>DATE</u>
Submit Approval Drawings	Four (4) weeks ARO
Drawings returned by Engineer	Two (2) weeks after submittal
Mobilize on Site	May 15, 2006
Complete Tank Assembly	June 15, 2006
Hydrotest complete	June 20, 2006
Paint and Interior Lining Complete	July 5, 2006
Demobilize	July 6, 2006

**EXHIBIT E**  
**SCHEDULING AND PROGRESS REPORTING PROCEDURES**

**EXHIBIT E**

**PROJECT SCHEDULING PROCEDURE  
AND  
PROGRESS REPORTING**

- 1.0 Introduction
- 2.0 Master Project Schedule
- 3.0 Drawing Schedule
- 4.0 Specification/Procurement Schedule
- 5.0 Subcontract/Procurement Schedule
- 6.0 CPM Schedule
- 7.0 Weekly Look-Ahead Schedule
- 8.0 Start-up Schedule
- 9.0 Progress Measurement
- 10.0 Progress Curves/Manpower Charts
- 11.0 Schedule Analysis
- 12.0 Local Expenditures
- 13.0 Monthly Progress Report
- 14.0 Installed Quantity Report

## 1.0 Introduction

The purpose of this Exhibit is to define the project scheduling procedure and progress reporting requirements which must be performed by the Contractor. Covanta requires compliance with this exhibit in order to monitor the Contractor's progress and verify compliance with the contract. The Contractor must provide complete, accurate and relevant information, such that decisions can be made and actions taken when appropriate, to assure timely completion of the work.

The Contractor shall plan, schedule their detailed activities, and control their work in accordance with the Contract schedule. The Contractor shall report progress and schedule status monthly and notify Covanta immediately of significant deviations or problems which could hamper the scheduled completion of work.

The Contractor shall develop their detailed schedules utilizing the critical path method (CPM) of scheduling. The Contractor shall update and report progress utilizing the most current version of Primavera Project Planner or Primavera SureTrak scheduling software.

The Contractor shall assign schedulers to the project who are proficient in using Primavera CPM scheduling software. The Contractor's scheduler shall have previous field scheduling experience in a construction management environment and have the ability to effectively coordinate and analyze all Contractor and subcontractor schedules. Contractor's scheduler shall be assigned full-time and be located at the jobsite. The Contractor's scheduling personnel shall be capable of fulfilling the requirements described in this Exhibit.

## 2.0 Master Project Schedule

The Master Project Schedule is a summary schedule which sets forth the overall schedule objectives of the project. The Master Project Schedule has been prepared on one page in a time-scaled logic format and shows the sequence and inter-relationships between major project activities. It contains the timeframes for engineering, procurement, construction and start-up activities.

Each month this schedule will be "stated" by Covanta based on input from the Contractor. Covanta will graphically place a "Time-Now Line" on the schedule. This line shall start at the top of the schedule at the end of the appropriate month and proceed vertically down the page moving to the left for delinquent items and to the right for items ahead of schedule.

## 3.0 Drawing Schedule

The Contractor shall prepare a Drawing Schedule which contains all design drawings to be developed. It shall include scheduled, actual and predicted dates for the following milestones: start drawing, drawing 30% complete, drawing 70% complete, issue for bids (if applicable;

approximately 90% complete where possible), Issue For Construction (IFC) and drawing 100% complete.

#### 4.0 Specification/Procurement Schedule

The Contractor shall prepare a Specification/Procurement Schedule which contains equipment to be purchased. It shall include scheduled, actual and predicted dates for the following milestones: issue spec for review, Covanta comments, issue bid spec, request for bids, receive bids, technical evaluation to Covanta, Covanta approval of technical evaluation, issue purchase order, and delivery.

#### 5.0 Subcontract/Procurement Schedule

Contractor shall develop a Subcontract/Procurement Schedule which contains all construction subcontracts and major material contracts which the Contractor expects to award. The schedule shall be submitted to Covanta within thirty (30) calendar days of Notice-To-Proceed. The schedule shall include scheduled, actual and predicted dates for the following milestones: issue for bid, receive bids, award of subcontract (or purchase order), start field work and complete field work, (or for material or equipment purchase on-site delivery dates).

#### 6.0 CPM Schedule

Utilizing the Master Project Schedule as a basis, the Contractor shall develop their detailed schedules employing the critical path method (CPM Schedule). The Contractor shall utilize the CPM Schedule for scheduling, coordinating and monitoring their Work.

Covanta shall integrate the Contractor's CPM schedule and the schedules from other County Contractors and suppliers, into an overall CPM schedule. The Contractor shall be responsible for the accuracy and thoroughness of the Contractor's input into the integrated CPM schedule. Covanta shall use the integrated CPM schedule to coordinate all construction activities and enabling the Project to progress in accordance with the Master Project Schedule.

The Contractor's CPM Schedule shall be a detailed work plan, not a duplication of the Master Project Schedule, and will be an integrated activity sequence, using the Precedence Diagramming Method (PDM). In most cases individual activities shall not have durations longer than twenty (20) work days. The duration of each CPM Schedule activity shall be based upon planned material quantities to be installed and planned man-hours to be expended. The Contractor shall input all manpower resources for each activity.

The Contractor must be able to identify the critical and sub-critical paths. Contractor's construction CPM Schedule shall contain a lead-in activity for each deliverable (i.e. engineering design drawing release or material delivery) which is a constraint to its construction network schedule. The Contractor shall conform to the activity numbering system

and code structure established by Covanta or other system/structure as mutually agreed upon.

Contractor shall include in the CPM Schedule a detailed Start-up Schedule (see Section 8.0 below). In support of the Start-Up Schedule Contractor should show installation activities for equipment, large bore pipe, small bore pipe, instruments, instrument tubing, instrument cable, instrument terminations, electrical trays and conduit, power and control cable and power and control cable terminations.

A preliminary CPM Schedule shall be submitted to Covanta within thirty (20) calendar days after the Notice-To-Proceed. It shall cover in detail work activities planned for ninety (90) calendar days following Notice-To-Proceed and a summary of activities which properly depict the Contractor's approach to the scheduling of all remaining work activities. Contractor shall incorporate the Start-up Schedule into its preliminary CPM Schedule.

A final detailed CPM Schedule, covering in detail the entire project, is to be submitted for Covanta's approval within ninety (45) calendar days after Notice-To-Proceed.

If either the preliminary or detailed CPM Schedule is not in accordance with this Exhibit E, then it must be re-submitted at the Contractor's expense within five (5) work days and continue to be re-submitted until the schedule is acceptable to Covanta.

Utilizing the CPM method, the Contractor shall continually anticipate and be aware of factors which are delaying or could delay schedule and shall take such remedial actions necessary to eliminate or minimize delays.

Each month the Contractor shall update their CPM network to reflect current project status. The Contractor shall, for each activity in progress, evaluate progress to date and estimate the remaining duration for each activity. This result shall be entered into the computer. The actual start and completion dates for activities shall be accurately entered based upon the Contractor's records.

Unless there is new information which necessitates changes to sequence, constraints, durations or deletes an activity, activities which have not started shall remain in the system as is. However, from time to time it will be necessary for the Contractor to revise its activity sequence and/or durations to enable the Project to remain on schedule or to reflect current project status. The Contractor shall provide Covanta with a list of any changes made to the CPM Schedule at the time the change is made. This list shall be itemized and include activity number, activity description, description of change, and reason for change.

Contractor shall provide Covanta with the following monthly CPM computer printouts:

1. Tabular report sorted by total float
2. Tabular report sorted by early start dates
3. Tabular report sorted by activity number

4. Project barchart schedule showing current and target early bars and also including current early start/finish dates and total float
5. Sixty (60) day look-ahead barchart schedule
6. Tabular variance report comparing actual and current projected dates to the target schedule

The computer printouts shall be updated to show remaining activity duration, % complete, actual start/finish dates, early start/finish dates, late start/finish dates, and float. Additionally, the Contractor shall provide a Primavera backup file for each update on diskette or via e-mail.

If the CPM Schedule shows the Contractor to be twenty (20) work days or more behind schedule at any time during the project regardless of cause, Contractor shall, at no cost to Covanta, prepare a CPM recovery schedule showing how compliance with the contract dates will be restored. The recovery schedule, along with a narrative discussion of the methods being employed to recover the schedule, shall be submitted to Covanta prior to the submission of the next monthly invoice.

#### 7.0 Weekly Look-Ahead Schedule

Each week Contractor shall provide Covanta a detailed Weekly Look-Ahead Schedule which identifies each area and effort of concentration for the current week and the following two weeks. This schedule shall include the detailed Weekly Look-Ahead Schedule for all Subcontractors.

#### 8.0 Start-up Schedule

Contractor shall include within the CPM Schedule a detailed Start-up Schedule for the Facility. The Start-up Schedule should include all Contractor activities for each system or portions of systems necessary to make them mechanically and functionally complete, energized, satisfactorily tested, and operable (with the exception of minor punch list items).

#### 9.0 Progress Measurement

Contractor shall prepare and submit to Covanta a detailed weekly rate of installation progress chart for material to be mutually agreed upon. This chart will show for each commodity the planned and actual quantity installation to support the schedule. The planned rate of progress should be consistent with anticipated manpower, work space limitations, and equipment, material, and drawing constraints.

In addition, Contractor shall also present this rate of progress information in the form of planned vs. actual cumulative curves.

Deviations from planned progress should be discussed in a narrative cover report. Problems affecting progress should be addressed along with solutions being recommended or implemented. The remaining durations of Primavera CPM Schedule activities should be adjusted to reflect the actual



rate of material installation and the schedule re-calculated to determine the impact of progress on the overall schedule. This impact should also be addressed in the cover report.

The application of Section 9.0 Progress Measurement is in addition to, and not in lieu of, progress and quantity information requested under Section 10.0 Progress Curves/Manpower Charts and Section 14.0 Installed Quantity Report.

#### 10.0 Progress Curves/Manpower Charts

The Contractor shall maintain progress curves showing planned vs. actual cumulative % complete for each discipline and subcontract as well as overall. Progress shall be based upon a physical evaluation of work complete and not contract amount spent. The Contractor shall provide Covanta with their methods of calculating percent complete.

Each day Contractor shall provide Covanta's Resident Construction Manager with a tabulation of actual manpower by craft. This tabulation shall include all subcontractor personnel. Contractor shall also provide on a monthly basis manpower charts showing planned and actual manpower for each discipline as well as overall.

#### 11.0 Schedule Analysis

The Contractor shall include in their monthly reports a section entitled, "Schedule Analysis". This section should contain a discussion of the status of activities relative to the critical path, Master Project Schedule and any special factors which are critical to achieving the scheduled completion of the work. Changes in schedule from the previous month must be highlighted, and deviations from planned % complete should be discussed. Any new or continuing problems affecting schedule must be addressed along with solutions being recommended or implemented. This section should mention major activities relative to the Master Project Schedule to be started or completed in the next month and any change in the scheduled completion of major project milestones.

#### 12. Local Expenditures

The Contractor shall maintain a running account of monthly expenditures for services, materials and labor from local suppliers. The account should be for payments made to craft labor for salaries, fringes, etc. Testing laboratories, consultants, haulers, rental firms, etc. are considered local suppliers. Exclude fees paid to governmental agencies. Local is defined as within a 50 mile radius of the Project Site.

#### 13. Monthly Progress Report

The Contractor shall provide Purchaser with a Progress Report each month. The report shall contain a narrative discussion of status; address organization and staffing; discuss overall

progress including percent of work completed; contain a description of progress for the reporting month and plans for the subsequent month; contain detailed progress and manpower charts/curves; contain problem areas/exception report; contain record of meetings; discuss assigned subcontracts; contain a schedule analysis; contain information related to affirmative action, minority-, female-, and disabled owned businesses; contain safety statistics; and any other information which Covanta may reasonably request.

14. Installed Quantity Report

Each month Contractor shall provide Covanta with a report which lists all categories of material and associated quantities. The report will be updated to show quantities of material installed, percent complete, etc.

EXHIBIT F

(NOT USED)

**EXHIBIT G**

**Covanta Contractor Safety Requirements**

Safety Procedure No. 5  
Contractor Safety Requirements

---

(A Covanta Energy, Inc. Facility)

**Contractor Safety Requirements**

(See page 2-3 for S.P. No. 5 Table of Contents)

Issued by: \_\_\_\_\_

*John M Klett*  
John Klett, SVP, Operations

\_\_\_\_\_  
June 4, 2004

Date

Acknowledged by: \_\_\_\_\_

\_\_\_\_\_  
Facility Manager

\_\_\_\_\_  
Date

Contractor Safety Requirements

The following safety requirements apply to all Contractors contracted by Covanta Energy, Inc. (CE, Inc.) to conduct work within the boundaries of a CE, Inc. owned and/or operated Facility, including all contractor personnel, their subcontractors, and any hiring hall and temporary employees hired and supervised by the contractor and not supervised by CE, Inc.. It is the Contractor's responsibility to notify and enforce all aspects of this document and all local, state and federal regulations pertaining to safe work practices of any and all of its employees while conducting work under contract to CE, Inc. at the Facility. CE, Inc. will not act as the "controlling" employer with respect to the Contractor under OSHA Directive CPL 2-0.124 – Multi-Employer Citation Policy. **Non-compliance by the Contractor with conditions of the contract or with CE, Inc. health and safety policies may be documented to the contractor by CE, Inc. facility management using the form contained in Appendix G.** Additionally, failure of any contractor, temporary employee or subcontractor employee to be in compliance with the federal/state/local regulations and CE, Inc. procedures as stated in this document and its appendices shall result in CE, Inc. removing any and all individuals/contractors from the site, at CE, Inc.'s sole discretion. Further disregard of the requirements of this contract by any contractor or subcontractor may result in the termination of the contract with CE, Inc.

As a condition of contract award, an officer of the Contractor's company must sign, date and return this page to CE, Inc. management before work can commence.

By signing this page, the Contractor certifies they have read and agree to administer the rules and regulations as outlined in the balance of this document. This signature page shall be kept on file at the Facility for one year from the date posted below and will apply to all future contracts.

_____	_____
<i>CE, Inc. Facility Representative</i>	<i>Date</i>
_____	_____
<i>CE, Inc. Facility Name</i>	<i>Date</i>
_____	_____
<i>Contractor Representative</i>	<i>Date</i>
_____	_____
<i>Contractor Company Name</i>	<i>Date</i>

**Table Of Contents**

**I. General Safety Procedures..... 4**

- A. Entering Facility
- B. Protective Work Clothing
- C. Housekeeping
- D. Personal Hygiene Practices
- E. Change Rooms
- F. Administrative Areas
- G. Hearing Protection (NRR $\geq$ 27)
- H. Eye Protection
- I. Fire Alarms/Evacuation
- J. Fire Prevention
- K. Clearance and Locking Procedures
- L. Confined Space Entry
- M. First Aid Locations
- N. Hot Work
- O. Hazard Communication (HAZCOM)
- P. Compressed Gas
- Q. Blood borne Pathogens
- R. Chemical Processes
- S. Furnace/Boiler Entry
- T. Fall Protection
- U. Scaffolding
- V. Blast Cleaning Procedures
- W. Radiation detectors
- X. Electrical Safety
- Y. Sandblast Material

**II. Worker Conduct..... 9**

- A. General Facility Rules
- B. Sexual Harassment

**III. Heavy Metal Exposure ..... 9**

- A. Exposure to Lead/Arsenic/Cadmium
- B. Federal Regulations
- C. Protective Overalls
- D. Showers
- E. Medical Surveillance

**IV. Respiratory Protection ..... 11**

- A. Respirator Selection
- B. Respiratory Fit Testing
- C. Respirator Types
- D. Respirator Selection Guide

**V. Competent Person List ..... 12**

**VI. Guidelines for Evaluating Contractor Health and Safety Performance and Programs ..... 13**

**VII. Contractor Pre-Job Briefing Checklist ..... 13**

Appendix A - Eye Protection Requirements ..... 14

Appendix B - Contractor Respirator Selection Guidance ..... 15

Appendix C - Fire and Emergency Response or Action Plan ..... 17

Appendix D - Smoking Policy ..... 18

Appendix E - Facial Hair Policy ..... 19

Appendix F - Other Site-Specific Requirements ..... 21

Appendix G - Contractor Contract Violation Notification Form ..... 22

Appendix H – Prospective Contractor Health and Safety Questionnaire ..... 23

Appendix I – Guidelines for Evaluating Contractor Health and Safety Performance and Programs ..... 25

Appendix J - Contractor Briefing Checklist ..... 34



**I. General Safety Procedures**

- A. Entering Facility: All Contractor personnel shall enter the Facility through the front entrance or the designated Contractor's entrance; and shall both sign in upon entering facility and sign out when departing from the facility, using the visitors or contract employee log. *No one should enter through the boiler house or air pollution control (APC) area when reporting to work, unless specifically instructed by CE, Inc. management.*
- B. Protective Work Clothing: All Contractors shall insure that all personnel are equipped with the following minimum equipment during any work performed at the Facility: hard hats, eye and hearing protection, hard-soled work shoes or boots and long sleeve shirts and long pants. Other equipment, such as respirators, cloth or disposable coveralls, leather-palmed gloves, shoe coverlets, welding jackets or electrical switching jackets may be required as a minimum, depending on the job performed. Contractor personnel are not permitted to work in the Facility wearing exposed tank top shirts, tee shirts or shorts. Additionally, sneakers, sandals or dress shoes are not permitted in the work area.
- C. Housekeeping: Contractors shall not use compressed air to clean equipment or tools. Equipment and tools should be vacuumed, wiped and/or washed in lieu of using compressed air. All air line hoses, welding leads and other equipment lines shall be kept clean and orderly so as not to contribute to slip/trip/fall hazards.
- D. Personal Hygiene Practices: Contractor personnel are not permitted to eat, drink, smoke or chew tobacco/gum, or apply cosmetics anywhere in the Facility where work area signs (e.g. Lead/Arsenic/Cadmium) or warning signs (e.g. flammable liquids, compressed gas) are posted. Furthermore, contractor personnel are only allowed to smoke in designated areas. See the attached smoking policy.
- E. Change Rooms: All Contractor personnel shall change in clean rooms provided by the Contractor or Facility based upon the terms of the contract. Contractor personnel are not permitted in CE, Inc. employee locker rooms unless specifically instructed by CE, Inc. management.
- F. Administrative Areas: Contractor personnel should not enter the lunchroom or any administrative areas (i.e. restrooms, office areas) and the control room wearing dirty coveralls (cloth or disposable) or other soiled garments. These items should be removed prior to entering any of these areas. All personnel shall vacuum off their clothing and clean the bottom of their shoes prior to entering any of these areas.
- G. Hearing Protection (NRR $\geq$ 27): Hearing protection devices, having a noise reduction rating of 27 or greater, shall be worn by all personnel throughout the Facility while any of the process equipment is in operation, exclusive of the administrative offices, control room, crane cab, outside grounds away from operating equipment, maintenance shop and break rooms, while any of the process equipment is in operation. Also, regardless of the Facility status, all personnel engaging in or around any activities which generate noise above Federal or State Occupational Safety and Health Administration (OSHA) regulatory limits shall wear hearing protection devices at all times.

Contractor Safety Requirements

- H. Eye Protection: Eye protection gear shall be worn by all personnel throughout the Facility, exclusive of the administrative offices, control room, crane cab and break rooms. All personnel wearing prescription glasses must also wear side shields or safety goggles over their glasses at all times, except as noted above.

Appendix A contains the minimum eye protection requirements for employees who are engaged in various work activities. The Contractor is responsible for assuring that all of their employees are equipped with at least the minimum protection for the job being performed.

- I. Fire Alarms/Evacuation: The Facility is equipped with a fire alarm and/or evacuation system. In the event of a fire or a forced evacuation, all personnel must leave their work areas and meet in the Administration Building parking lot or other designated area for a head count. A Contractor representative shall maintain records of contractor personnel on site and will bring that information to the evacuation area in the event of an emergency. Exits are marked throughout the plant. **In the event of a fire no one shall use the elevator.** The Control Room operator will announce an "ALL CLEAR" or "FALSE ALARM" if there is no danger. Please review Appendix C for site specific fire evacuation procedures.
- J. Fire Prevention: Fire extinguishers, fire hoses and fire alarms are located throughout the Facility. If a fire is observed, it should be reported to the Control Room immediately. If there is a danger present, personnel should move calmly and in an orderly fashion to the nearest exit and report to their designated areas.
- K. Clearance and Locking Procedures: Any electrical or mechanical equipment being worked on **MUST** be locked and tagged out in accordance with the CE, Inc. lockout/tag-out procedures before the commencement of work. Each contractor employee, who is working on equipment that is required to be locked and tagged, shall provide his or her own personal safety lock. All Contractors shall comply with the following:
1. Before starting work on any equipment in the facility, the equipment shall be rendered safe by locking and tagging out any mechanism that could potentially cause a hazard to personnel. No Contractor is permitted to request a Clearance in their own name. All Clearance requests shall be initiated on the Contractor's behalf by a CE, Inc. management employee listed on the facility requestor list (*Safety Procedure No. 15, Lockout/Tag-out*). Prior to starting work, Contractors should review the locking and tagging procedures for areas in which their personnel will be working. If Contractor personnel have any questions regarding lockout/tag-out, a member of CE, Inc. management should be consulted before any work commences.
  2. No person shall operate, maneuver, change the position of, or otherwise modify the status of any device or piece of equipment that has been locked and tagged as part of the lockout/tag-out work clearance permit.

Contractor Safety Requirements

3. Individuals working on equipment which has been locked out and cleared shall do so only after first affixing their personal safety lock to the Clearance Key Box located in the control room and signing the log sheet for that particular job. The employee's lock shall be removed by the individual immediately upon termination of work or at the end of each shift. Contractor Safety Locks shall be clearly labeled and the Contractor shall provide the Operations Shift Supervisor acting as the CLA with means to determine the identity of a worker from the lock label.
  
- L. Confined Space Entry: CE, Inc. procedures for confined space entry must be followed. The Shift Supervisor or his designee shall control such entries via the Confined Space Entry Permit. Before this Permit is issued, the confined space must be monitored for oxygen concentration, flammable vapors, toxic gases, temperature and potential heat stress conditions and mechanical hazards. A pre-entry briefing must be held with all entrants, attendants, supervisor(s) and/or the Shift Supervisor authorizing the work prior to commencing work. The results of the pre-entry tests will be reviewed with the Contractor's site supervisor. If hot work is to be performed in a confined space, the provisions of the hot work section of this agreement shall also apply. The Contractor shall be responsible for providing necessary ventilation to eliminate or control any atmospheric hazards that they create due to their work activities
  
- M. First Aid Locations: First aid kits are located throughout the facility. Facility personnel are also trained in CPR and first aid procedures. Minor injuries may be treated at the Facility but more serious injuries will be directed to the Facility-associated clinic or local hospital.  
  
*If a contractor's employee has an accident or they witness an accident, it must be reported to the CE, Inc. Shift Supervisor immediately. An injured contractor requiring medical treatment will not be permitted to leave the site unaccompanied.*
  
- N. Hot Work: Any employee performing flame cutting, welding, brazing, grinding or any procedure involving an open flame or sparks must be issued a hot work permit before starting work. Such permits can be obtained from the on duty CE, Inc. Shift Supervisor or his designee, who shall review the work area with the requestor prior to issuing a hot work permit. Also, any Contractor performing any hot work or spark generating activity in or around raw or processed refuse must maintain a fire watch and keep fire fighting equipment in the immediate area of the hot work. Any area susceptible to fire must first be cleaned and then soaked with water before the commencement of work.  
  
The Contractor will insure all welding operations are adequately ventilated at all times as required by 29 CFR 1910. 252 of the OSHA (or other applicable State) regulations. The contractor shall provide mechanical ventilation unless otherwise specified in the contract.  
  
The Contractor shall provide copies of material safety data sheets for all welding supplies used to CE, Inc. management prior to the commencement of work.
  
- O. Hazard Communication (HAZCOM): Material Safety Data Sheets (MSDS) for all chemicals in the Facility are kept on file in books located in the Facility control room and/or Administration area. This information is to be maintained on site and made

Contractor Safety Requirements

available to any individual(s) requesting to see it. The Shift Supervisor may review this information prior to initiating work involving such chemicals. All Contractors are required to provide MSDS for all materials (welding rods, paints, lubricants, solvents, acids, compressed gasses, sandblast materials, etc.) brought to the facility for which they may use during the course of their work. This information must be presented to and reviewed by the CE, Inc. management prior to the commencement of any work.

- P. Compressed Gas: Any compressed gas cylinders in use or in storage must be firmly secured to a solid structure. Gas cylinders can only be stored in locations designated by the Facility. Fuel gases must be stored separately from oxygen and/or other oxidizers unless in use and/or stored in a mobile rack for use.
- Q. Bloodborne Pathogens: Contractor personnel engaged in activities where uncombusted refuse or bottom ash/riddling residue is present should avoid physical contact with this material. Although not hazardous in nature, this material may contain a limited amount of sharps or other products that may have been exposed to blood or bodily fluids. These items may contain microorganisms, which are the carriers of diseases such as Hepatitis B Virus (HBV) or Human Immunodeficiency Virus (HIV).

If Contractor personnel discover or come in contact with bloodstained products, sharps such as needles, or has a blood/body fluids exposure from an injured individual, e.g., as a result of rendering first aid, CE, Inc. management should be contacted immediately for appropriate action. No Contractor personnel should work in any area containing this material without protective gear such as gloves and coveralls. Contractor personnel should avoid activities such as physically handling or walking through piles of loose material.

- R. Chemical Processes: The Facility may contain a limited amount of highly hazardous chemicals that have the potential for fire, explosion or toxic release. Access to these areas is strictly limited and regulated by CE, Inc. management. Any Contractors working in these areas shall be provided by CE, Inc. management with information regarding these chemicals in the form of MSDS and must train their employees working in or near the chemical hazard area. Additionally, the Contractor must provide the Facility with MSDS and other PSM details for all chemicals or material that will be used in the course of the Contractor work before the commencement of this activity.
- S. Furnace/Boiler Entry: - **CAUTION** - Ash has the potential to retain heat for long periods of time after the furnace/ boiler has been shut down and cooled for entry. This ash often collects along the furnace walls, gas pass walls and tube pennants areas and may retain heat for long periods of time. Contractors must take extreme care when entering and working in these areas. Upon entry, if ash is seen, a member of CE, Inc. management should be advised of the situation and any ash removal must be performed under CE, Inc. direction. In order to avoid serious burns or other injuries, personnel should always be positioned above the ash deposit to be removed.
- T. Fall Protection: If there is a fall potential of six (6) feet and/or a fall exposure of four (4) feet or more then the use of fall protection is required. The preferred method of fall

protection is to eliminate the fall hazard by engineering controls such as: work platforms, scaffolding, guardrails, etc. If the fall hazard cannot be eliminated, then all personnel exposed to the fall hazard are required to use harnesses and lanyards to provide fall protection. All fall protection equipment used shall meet the ANSI standards and comply with the most recent Federal or State OSHA regulations.

- U. Scaffolding: All scaffolding shall be used and erected in accordance with 29 CFR 1910.28 and 29 CFR 1926.451-.453 of the OSHA regulations and any applicable state and/or local regulations. All scaffolding shall have top rails, mid rails and toe boards on all open sides. All scaffold must be properly grounded. Each person working from a single point or multi point suspended scaffolding shall use an independent lifeline(s) and harness(es). At no time shall damaged or defective scaffolding components be used.

Scaffold and scaffold components shall be inspected for visible defects by a competent person before each work shift and after any occurrence that could affect a scaffold's structural integrity (also refer to Section V.). Any scaffold, including accessories such as braces, brackets, trusses, screw legs, ladders, or platforms, that is damaged or weakened from any cause shall be immediately repaired or replaced. Any scaffold or accessories that are repaired shall have at least the original designed strength of the scaffold or accessory.

Contractors shall have each of its employees who performs work while on a scaffold trained by a person qualified in the subject matter to recognize the hazards associated with the type of scaffold being used and to understand the procedures to control or minimize those hazards.

- V. Blast Cleaning Procedures: Blasting agents may be used in the facility during outages to loosen accumulated ash on the internal surfaces of the boilers or other vessels. Only authorized and qualified persons from the company hired to perform the blasting operation will be permitted to handle and use these blasting agents. All contractors must follow the facility's Standard Operating Procedures (SOPs) related to blasting to ensure absolute safety during the blast cleaning procedures. The devices must be locked out and the source shielded before any work can commence.
- W. Level/Flow Gauge: The facility may have radioactive measuring devices to detect level or flow gauges on certain pieces of equipment, such as lime slurry lines or RDF hoppers. Contractors who may be performing work in the area of the facility where these devices are mounted will be notified in advance of the presence and location of the measuring device.
- X. Electrical Safety: Contractors who may be involved in electrical work will be expected to comply with the applicable regulations, including satisfaction of training requirements and will not wear clothing that, when exposed to flames or electrical arcs, could increase the extent of injury that would be sustained by the worker. Contractors are required to furnish GFCIs for each piece of equipment that is plugged into an outlet at a Covanta facility.
- Y. Sandblast Material: Contractors are expected to review sandblast material MSDSs and to understand work practice, PPE and personal hygiene requirements when handling sandblast material with silica and/or NORM content.

**II. Worker Conduct**

- A. **General Facility Rules:** The Contractor is responsible for the conduct of their employees. The possession or use of alcohol, illegal substances/drugs and, firearms are strictly prohibited. Fighting or attempting bodily injury to another, being under the influence of alcohol and/or illegal drugs, conduct which violates the common decency or morality of the community, stealing, scavenging or pilfering any materials waiting to be processed, malicious mischief which results in the injury or destruction of company or employee property is also prohibited. Any persons found to be involved in any of the above activities, shall be disciplined by the Contractor management and may be removed from the Facility by CE, Inc. Management.
- B. **Sexual Harassment:** CE, Inc. prohibits the unlawful harassment of its employees. Actions, words, jokes or comments based on an individual's sex will not be tolerated. Sexually-oriented materials on site, i.e., books, photos, will not be tolerated. Likewise unwelcome sexual advances, requests for sexual favors and all other verbal or physical conduct of a sexual or otherwise offensive nature is prohibited.

Any personnel, who are found to be involved in any of the above activities, may be removed from the Facility by CE, Inc. Management.

**III. Heavy Metal Exposure**

- A. **Exposure to Lead/Arsenic/Cadmium:** Under certain conditions, Contractor personnel may be exposed to airborne ash/dust generated by the combustion process, which may contain Lead/Arsenic/Cadmium particulate. Ambient air monitoring conducted by CE, Inc. has determined that during certain maintenance activities, primarily internal to the stoker, steam generator, duct work and APC equipment; Lead/Arsenic/Cadmium concentrations above Federal or State OSHA's Permissible Exposure Limit (PEL) have been occasionally present. Industrial Hygiene monitoring results are available for review with CE, Inc. management. Contractors must notify, review and train all of their personnel who are involved in activities that may come in contact with airborne dust containing these contaminants. Training sessions must inform all employees on the hazards and precautions to take to minimize exposure to Lead/Arsenic/Cadmium. Information in this document, including correct work and hygiene practices, must be incorporated into any training session.
- B. **Federal Regulations:** Federal regulations established by OSHA have set the allowable limits for contaminants a worker may be exposed to during the course of their work shift. The PELs stated below are based on an 8-hour Time-Weighted Average (TWA) (note: for 10 or 12 hour shifts, the PEL are decreased according to the formula provided in 29 CFR 1910.1025). Past employee exposure monitoring has demonstrated Lead, Arsenic and Cadmium as the three most prominent OSHA regulated heavy metals that workers may be exposed to while performing certain maintenance duties at a CE, Inc. Facility. The 8-hour time-weighted averages (TWA) PELs are as follows:

<b>Lead</b>	<b>0.05 mg/m<sup>3</sup></b>
<b>Arsenic</b>	<b>0.01 mg/m<sup>3</sup></b>
<b>Cadmium</b>	<b>0.005 mg/m<sup>3</sup></b>

Contractor Safety Requirements

The specific regulations, which pertain to occupational exposure to the above heavy metals, can be found in the Code of Federal Regulations (CFR) Volume 29, Section 1910.1025 for Lead, Section 1910.1018 for Arsenic and Section 1910.1027 for Cadmium or in the related Lead, Arsenic and Cadmium sections from the construction industry standards, 29 CFR 1926 (for contractors working under these regulations). Contractors must comply with these regulations and all applicable state and local regulations and become familiar with them before conducting work at the Facility. Contractors are obligated by law to distribute copies of Appendices A and B of the Lead regulation as contained in 29 CFR 1910.1025, Appendix A of the Arsenic regulation as contained in 29 CFR 1910.1018, plus the entire Cadmium regulation as contained in 29 CFR 1910.1027 to their employees before the commencement of work. Copies of these regulations are contained in the "Contractor Safety Supplement" package, which is available to contractors at their request to the Facility. If state or local regulations are more stringent than the applicable federal standard(s), then the more stringent regulations are to be followed.

- C. Protective Coveralls: All Contractor personnel exposed to Lead/Arsenic/Cadmium, at the end of each work shift or the beginning of an organized break, must vacuum off their coveralls using a HEPA vacuum before removing them. Once removed, the garments should be placed in the appropriate marked containers located by the vacuum or other area. All paper coveralls or other disposable coveralls shall be placed in these labeled containers for disposal, while all cloth coveralls shall be placed in plastic bags supplied by the Contractor or laundry vendor. Personnel shall not shake or blow off clothing with compressed air since this may cause the dust to become airborne. Personnel shall not wear soiled work clothing home or to a hotel since this has the potential to expose family members to contaminants that may accumulate in an employee's house or car or hotel personnel.
- D. Showers: Federal regulations require that all personnel who work in an area that is over the PEL for Lead/Arsenic/Cadmium shower prior to leaving the Facility. Any items worn under protective coveralls during the work shift should be carried home in a plastic bag and cleaned separately from other household laundry.

The Contractor is responsible for assuring that all personnel under their supervision who have potentially been exposed to levels above the PEL shower before leaving the Facility.

- E. Medical Surveillance: The Contractor is responsible for providing a medical surveillance program, including blood lead monitoring for all personnel under their supervision and exposed at or above the action level to lead, arsenic and/or cadmium. The OSHA 1926 regulations require medical surveillance monitoring when exposed one day or more while the 1910 regulations require medical surveillance monitoring after 30 days.

**IV. Respiratory Protection**

A. Respirator Selection: By law, Contractors must provide appropriate respiratory equipment to all of their employees. The degree of protection required is dependent upon three (3) main criteria in the following order:

1. The nature of the work activities the employee is engaged in,
2. The location in the Facility where the employee is working and
3. The present and/or expected condition of the equipment (clean, dirty, etc).

All Contractors conducting work at the Facility must provide and enforce their own respiratory protection program in compliance with 29 CFR 1910.134.

Appendix B is a chart that provides a respirator selection guide for any Contractor employee working at the Facility. These requirements are based upon the results of extensive air monitoring conducted by CE, Inc. at each of its Facilities. Contractors must adhere to these respirator requirements as a minimum and equip their employees as appropriate. Contractors must provide, inform and train their employees regarding the use of respiratory protection in accordance with any and all applicable federal, state and local laws.

- B. Respiratory Fit Testing: By federal regulation, a Contractor must conduct a qualitative fit test on all employees who will be wearing a respirator regardless of type. In addition, the federal Cadmium standard, and certain state regulations, also requires quantitative testing to be done. This test should be conducted, if possible, before an employee reports to the Facility for work. All tests must include training on the type of respirator(s) to be worn and documentation that the employee received and understood these tests. This documentation must be kept on file for a minimum of one (1) year from the date of the test.
- C. Respirator Types: A Contractor may choose from several different types of respirators to meet the requirements of Appendix B; however, each type of respirator has its limitations. The following Respirator Protection Guide outlines various types/styles of respirators commonly found in industry.
- D. Respiratory Selection Guide: All respirators used shall be Mine Safety and Health Administration (MSHA)/National Institute for Occupational Safety and Health (NIOSH) approved.
1. Half Face Masks (HFM) for comfort: For comfort, HFM can be worn in the presence of nuisance dusts or in situations where the environment is known or measured to be below the PEL. HFMs cannot be used in situations where the ambient level of oxygen is below 19.5%.
  2. 10 X the PEL: Typically, only **half-face mask negative-pressure air purifying respirators (HFM)**, carrying a MSHA and NIOSH approval which reads "approved for respiratory protection against dusts, fumes and mists having TWA less than 0.05 milligrams per cubic meter and radionuclides will meet this requirement. These



masks or replaceable canisters must be appropriate for exposure to Lead/Arsenic/Cadmium. Air purifying respirators cannot be used in situations where the ambient level of oxygen is below 19.5%.

3. 50 X the PEL: Typically, only **full-face negative-pressure respirators (FFM)** with HEPA filters changed regularly will meet this requirement. The canisters used in these masks must be appropriate for exposure to Lead/Arsenic/Cadmium. Air purifying respirators cannot be used in situations where the ambient level of oxygen is below 19.5%.
4. 1000 X the PEL for Lead/Arsenic and 250 x the PEL for Cadmium: Only a **full-face Positive Air Purifying Respirator (PAPR)** with HEPA filters changed no less frequently than each eight (8) hours, unless dust conditions indicate otherwise, will meet this requirement. The canisters used in these masks must be appropriate for exposure to Lead/Arsenic/Cadmium.
5. 2000 X the PEL for Lead/Arsenic and 1000 x the PEL for Cadmium: In order to achieve the above protection factors for Lead/Arsenic/Cadmium, **supplied air respirators (SA)** must be used. Air being supplied to the actual respirator must be grade "D" breathing air. Supplied air systems cannot be used in situations where the ambient level of oxygen is below 19.5%.
6. 10,000 X the PEL: In order to achieve a protection of 10,000 X the PEL for Lead/Arsenic/Cadmium, a **Self-Contained Breathing Apparatus (SCBA)** must be used. SCBA systems are acceptable for use in situations where the level of oxygen is below 19.5%.

V. **Competent Person List**

To assist Contractors contracted by CE, Inc. that may perform work regulated under the OSHA 29CFR1926 Construction Regulations, below is the list of construction regulations which include requirements for a Competent Person. When a Contractor's work requires Competent Person oversight by any of these regulations, Contractor Shall ensure that its staffing includes the necessary Competent Person(s) and that all regulatory requirements are satisfied by this person(s).

1926.20	General Safety and health provisions
1926.32	Definitions
1925.53	Ionizing radiation
1926.62	Lead
1926.101	Hearing protection
1926.103	Respiratory protection
1926.251	Rigging equipment for material handling
1926.354	Welding, cutting, and heating in way of preservative
1926.404	Wiring design and protection
1926.451	Scaffolding
1926.502	Definitions applicable to fall protection
1926.550	Cranes and derricks

Contractor Safety Requirements

1926.650	Scope, application, and definitions applicable to excavations
1926.651	General requirements
1926.652	Requirements for protective systems
1926 Subpart P App A	Soil classification
1926 Subpart P App B	Sloping and trenching
1926.705	Requirements for lift-slab operations
1926.752	Bolting, riveting, fitting-up, and plumbing-up
1926.800	Underground construction
1926.803	Compressed air
1926.850	Preparatory operations - demolition
1926.859	Mechanical demolition
1926.900	Blasting and use of explosives
1926.1053	Ladders
1926.1060	Training requirements – stairways & ladders
1926.1101	Asbestos
1926.1127	Cadmium

**VI. Guidelines for Evaluating Contractor Health and Safety Performance and Programs**

Just as CE, Inc. solicits bids from only those contractors that are technically qualified, it also determines whether a contractor has appropriate Health & Safety programs and procedures in place to comply with the specific work available for bid. The "Prospective Contractor Health and Safety Questionnaire" in Appendix H is used for that purpose.

Additionally, CE, Inc. will follow-up periodically regarding specific Health and Safety programs and practices and may ask Contractor to complete the applicable portions of "The Guidelines for Evaluating Contractor Employer Health and Safety Performance and Programs", included as Appendix I.

**VII. Contractor Pre-Job Briefing Checklist**

The checklist provided with this document as Appendix J should be used as a checklist when conducting pre-job briefings with Contractor personnel.

**Eye Protection Requirements**

- |  |   |
|--|---|
| 1. Minimum at All Times:   | Safety Glasses W/Side Shield                            |
| 2. Impact:<br>Lathe, Drill Press Work, Grinding Wire Wheeling,<br>Jack Hammering, Hilti Gun, Hammering, Chiseling  | Safety Glasses & Face Shield<br>or Goggles              |
| 3. Optical Radiation:<br>Flame Cutting, Welding  | Cutting/Welding Filter Lens                             |
| 4. Non-Corrosive Liquids:<br>Lube Oil, Hydraulic Work  | Goggles   |
| 5. Chemical:<br>A. Chemical Transfer, Acid and Caustic<br>Work, Denox System (Other Than Tank)   | Goggles and Face Shield                                 |
| B. Dry Lime  | Goggles   |
| C. Lime Slurry (Nozzle Cleaning, Slaker Work)  | Goggles and Face Shield                                 |
| D. Ammonia Tank Work   | SCBA  |
| 6. High Pressure:<br>Power Washing, High Pressure Steam, Compressed<br>Air, Fire Hose Wash Down, Working With Spring<br>Loaded Systems, Using Sharp Pointed Instruments,<br>Spray Painting | Goggles and Face Shield                                 |
| 7. Closed System/Furnace/Boiler/Cleaning:<br>Boiler Hopper Cleaning/Inspection, Baghouse and<br>Hopper Cleaning/ Inspection, Ash Discharger Work,<br>Grate/Feedtable Cleaning              | Goggles, Full Face<br>Respirator Use May Be<br>Required |
| 8. Electrical:<br>Racking High Voltage Breakers  | Safety Glasses & Face Shield                            |
| 9. Dust:<br>A. Ash Building, Wet Conditions  | Safety Glasses With Side Shield                         |
| B. Ash Building, Dry Conditions  | Goggles   |
| C. General Dusty/Windy Conditions  | Goggles   |

## Contractor Respirator Selection Guidance

Area	Condition	Activity	Required Respirator	Optional Respiratory Upgrade
Flue gas side of steam generator, stoker and APC equipment	As found- no prior cleaning	<ol style="list-style-type: none"> <li>Disassembly, repair or demolition of any equipment or components</li> <li>Water washing (from inside of the boiler)</li> <li>Removal of refractory</li> <li>Any manual cleaning</li> <li>Any inspection work not generating dust</li> <li>Any inspection work generating dust</li> <li>Re-assembly with new components</li> <li>Baghouse re-bagging cleaning or inspection</li> <li>Air lancing</li> <li>Abrasive Blasting</li> <li>Stick blasting</li> </ol>	FFM 50 X PEL HFM 10 X PEL FFM 50 X PEL PAPR HFM 10 X PEL FFM 50 X PEL HFM 10 X PEL FFM 50 X PEL SA Sandblast Hood good for Cd PF = 1000 HFM 10 X PEL	PAPR 1000 X PEL HFM 10 X PEL PAPR SA FFM 50 X PEL PAPR FFM 50 X PEL PAPR SA Sandblast Hood good for Cd PF = 1000 FFM 50 X PEL
Flue gas side of steam generator, stoker and APC equipment	Clean by water washing, sandblasting or extensive manual cleaning	<ol style="list-style-type: none"> <li>Disassembly, repair or demolition of any equipment or component (depending on amount of dust generated, see Note 1)</li> <li>Removal of refractory</li> <li>Any welding, cutting, grinding</li> <li>Installation of new components</li> <li>Any inspection work not generating dust</li> <li>Any inspection work generating dust</li> </ol>	HFM 10 X PEL FFM 50 X PEL HFM 10 X PEL HFM for comfort HFM for comfort HFM 10 X PEL	FFM 50 X PEL, PAPR PAPR FFM 50 X PEL HFM 10 X PEL HFM 10 X PEL HFM 10 X PEL
Any	Any	<ol style="list-style-type: none"> <li>Sandblasting</li> </ol>	Sandblast Hood good for CD PF = 1000	Sandblast Hood good for CD PF = 1000
Any	Any	<ol style="list-style-type: none"> <li>Air arcing or air plasma cutting of any used, in-place or in-service components anywhere</li> </ol>	FFM 50 X PEL	PAPR
Any	Any	<ol style="list-style-type: none"> <li>Gunitting of refractory</li> </ol>	FFM 50 X PEL	PAPR

Area	Condition	Activity	Required Respirator	Optional Respiratory Upgrade
Any	Any	<ol style="list-style-type: none"> <li>1. Unplugging/vacuuming/clearing hoppers including all stoker undergrate/riddling hoppers and ash dischargers</li> <li>2. Vacuuming flyash except hoppers</li> <li>3. Blowing equipment down</li> </ol>	FFM 50 X PEL  HFM 10 X PEL FFM 50 X PEL	PAPR  FFM 50 X PEL Activity should be avoided if possible
Bottom ash handling equipment	As found	<ol style="list-style-type: none"> <li>1. Disassemble and repair of equipment</li> <li>2. Welding, cutting, and grinding</li> </ol>	HFM for comfort HFM 10 X PEL	HFM 10 X PEL PAPR
Waste handling/processing equipment	Any	<ol style="list-style-type: none"> <li>1. Any crane work</li> <li>2. Any work in RDF processing area</li> </ol>	HFM for comfort HFM for comfort	HFM 10 X PEL HFM 10 X PEL
Any	Any	<ol style="list-style-type: none"> <li>1. Removal of insulation (non asbestos)</li> <li>2. Installation of new insulation</li> </ol>	HFM 10 X PEL HFM for comfort	FFM 10 X PEL HFM 10 X PEL
Fly ash handling equipment	As found	<ol style="list-style-type: none"> <li>1. Disassembly and repair of equipment</li> </ol>	HFM 10 X PEL	FFM 50 X PEL
Fly ash handling equipment	Cleaned by water or manually cleaned	<ol style="list-style-type: none"> <li>1. Disassembly and repair of equipment</li> <li>2. Grinding, cutting, welding</li> </ol>	HFM for comfort HFM 10 X PEL	HFM 10 X PEL FFM 50 X PEL
Ammonia, propane, sewage or leachate tanks	As found	<ol style="list-style-type: none"> <li>1. Any work inside vessels or confined areas</li> </ol>	SCBA	SCBA

NOTE 1: Disassembly of scaffold may result in dust generation that may affect the eyes and may warrant the use of higher levels of respiratory protection. Depending on the type of scaffolding, (e.g. metal deck scaffold planks) it may be difficult to clean due to ash accumulation in the holes and underside portions of planking. Limited numbers of data points have shown metal deck scaffold will re-entrain enough ash to warrant the use of a PAPR. Solid plank scaffold may not be as apt to capture and then, re-entrain ash. For these reasons, Covanta strongly recommends the use of full-face negative pressure respirators whenever scaffold deck is removed. In addition, Covanta recommends use of a PAPR by each employee that will be involved removing scaffold equipment for more than 4 hours.

HFM - Half Face Negative Pressure Air Purifying Respirator with HEPA Filter  
 FFM - Full Face Negative Pressure Air Purifying Respirator with HEPA Filter  
 PAPR - Full Face Positive Pressure Air Purifying Respirator with HEPA Filter  
 SA - Supplied Air Respirator  
 SCBA - Self Contained Breathing Apparatus

**Fire and Emergency Response/Action Plan**

### Smoke-Free Environment

#### Policy

---

This policy is dedicated to providing a healthy, comfortable and productive work environment for our employees.

#### Procedure

Smoking shall be prohibited in the following areas. The areas listed are the minimum requirements set forth for this policy.

- ⊗ Control Rooms
- ⊗ Administration Areas
- ⊗ Conference Rooms
- ⊗ Common Public Areas
- ⊗ Lunchrooms
- ⊗ Break Rooms
- ⊗ Lavatories
- ⊗ Locker Rooms
- ⊗ Tipping Floor
- ⊗ Ash buildings
- ⊗ Switch gear or MCC Rooms
- ⊗ Charging Floor
- ⊗ Picking Stations
- ⊗ RDF Processing and Storage Areas
- ⊗ Water laboratories
- ⊗ Within 25 feet of any flammable/combustible storage area
- ⊗ Boiler building during boiler outage periods (enclosed boilers)
- ⊗ Battery Room
- ⊗ Other Areas as Posted

Individual facilities may enforce policies that are more stringent than the above due to local concerns or city/state regulations. Consult with your facility administrative office for the exact requirements.

This policy applies to all employees, contractors, sub-contractors, temporary labor and visitors.

The success of this policy will depend upon the thoughtfulness, consideration and cooperation of smokers and non-smokers. All employees share in the responsibility for adhering to and enforcing this policy. Any problems should be brought to the attention of the appropriate supervisor and handled through the normal chain of command. Employees who violate this policy will be subject to the same disciplinary actions that accompany infractions of other company policies.

**Facial Hair Policy**

The current facial hair policy that has been in effect in all Covanta resource recovery facilities and related facilities since April 17, 1995 was updated on November 6, 1998 as follows:

Any employee, contractor and/or temporary employee whose job responsibilities require them to wear or to be trained in the use of a respirator or SCBA shall be clean shaven on every facial area where the respirator seals against the face, including the facial hair area around the inner-most perimeter of the respirator seal.

Specifically, full beards, goates and bushy sideburns are prohibited. Mustaches that do not interfere with the respirator sealing points (including the inner-most perimeter sealing points) are permitted.

No CEG/CE, Inc. employees, contractors, sub-contractors and/or temporary employees shall report for duty in violation of this policy.

If your job responsibilities require you to wear or to be trained in the use of a respirator or SCBA, please ensure your compliance with this policy. Failure to comply will result in disciplinary actions by your supervisor, up to and including dismissal.

This policy was signed and initiated on November 6, 1998 by John Klett, Executive Vice President, Covanta Energy Group.



**Position Paper: Facial Hair**

The AIHA Respiratory Protection Committee is publishing this statement in order to have the technical issue of facial hair and respirators clearly stated. Present OSHA respirator regulations contained in CFR 1919.134 are vague with respect to facial hair, which can interfere with the sealing surfaces of a respirator.

The purpose of a respirator is to protect the user from airborne materials, which are potentially hazardous to health. Consequently, the fit of the face piece to the user's face is critical if the device is to provide maximum protection. Organizations involved in developing consensus standards pertaining to respiratory protection, such as the American National Standards Institute (ANSI), have developed guidelines for assessing potential protection afforded by various respiratory protective devices. The most recent ANSI standards on respiratory protection, Z88.2 (1980), states, "A respirator equipped with a face piece shall not be worn if facial hair comes between the sealing periphery of the face piece and the face or facial hair interferes with valve function."

Beards and facial hair are incompatible with the proper seal of the negative and positive pressure tight fitting respirator face piece. There are a number of studies documenting this, the most well known of these was conducted by Hyatt, et al., at the Los Alamos National Laboratory. Test results indicated that the effect of facial hair on the performance of tight fitting respirators depend on the degree to which the hair interferes with the sealing surface worn in relation to the person's physical characteristics. From this study, it was concluded that persons with facial hair, such as long, bushy sideburns, full beards, goatees, and even stubble which lie between the face and the respirator sealing surface, cannot expect to obtain as high a level of respirator performance as persons who are clean shaven. A number of later studies have confirmed these results.

The Respiratory Protection Committee recommends strongly that respirators must not be worn by persons who have facial hair which exists where the sealing surface of respirator makes contact with the face.

The following documents are referenced in support of our position:

- A. Hyatt, E. C. et al.: Effects of Facial Hair on Respirator Performance, American Industrial Hygiene Journal 34: 135-142, 1973.
- B. ANSI Z88.2-1980, "Practices for Respiratory Protection", American National Standards Institute 1980, ANS Committee on Safety Standards for Respiratory Protection
- C. UCRL-85165, "Facial Hair and Breathing Protection", Lawrence...

**Other Site Specific Requirements**



**Prospective Contractor  
Health & Safety Questionnaire Prior to Selecting a Contractor**

Due to the nature of the work we may be requesting you to bid on in the future, Covanta Energy, Inc. (CE, Inc.) must ask you to fill out the attached questionnaire regarding your company and return it to your facility contact. Without this questionnaire filled out completely and returned, we will not be able to put you on our contractors bid list. These questions are asked so that we may be in compliance with all Local, State and Federal regulations.

Please answer the questions applicable to the work you would be doing.

1. Does your company have a written safety program?     Yes     No
2. Do you have a designated Safety Manager who is in charge of Safety programs for your company?  
 Yes     No
- a) Who is in charge of safety on the job site (Name and Title)? \_\_\_\_\_
3. Does your company have in effect and in writing the following safety programs and do you train employees as required by OSHA?

	Written Policy		Required Training	
	Yes	No	Yes	No
a) General Personal Protective Equipment (PPE) policy including hearing protection.	<input type="checkbox"/>	<input type="checkbox"/>	<input type="checkbox"/>	<input type="checkbox"/>
b) Haz-com	<input type="checkbox"/>	<input type="checkbox"/>	<input type="checkbox"/>	<input type="checkbox"/>
c) Confined Space/Lockout Tagout	<input type="checkbox"/>	<input type="checkbox"/>	<input type="checkbox"/>	<input type="checkbox"/>
d) Accident Reporting and Investigation Policy/Program	<input type="checkbox"/>	<input type="checkbox"/>	<input type="checkbox"/>	<input type="checkbox"/>
e) Fall Protection Program	<input type="checkbox"/>	<input type="checkbox"/>	<input type="checkbox"/>	<input type="checkbox"/>
f) Respiratory Protection Policy	<input type="checkbox"/>	<input type="checkbox"/>	<input type="checkbox"/>	<input type="checkbox"/>
g) Medical Surveillance Program (Lead, Arsenic and Cadmium)	<input type="checkbox"/>	<input type="checkbox"/>	<input type="checkbox"/>	<input type="checkbox"/>

4. Does your company have a written and enforced disciplinary action procedure regarding safety violators?  
Yes \_\_\_ No \_\_\_
5. Do you provide the correct number of Competent Persons when required by OSHA 29 CFR1926 Regulations?  
Yes \_\_\_ No \_\_\_ Which Regulations \_\_\_\_\_
6. If you use a subcontractor are they required to adhere to your companies safety policies and practices?  
Yes \_\_\_ No \_\_\_
7. What is your company's current OSHA incident rate? \_\_\_\_\_

-----

Company Name: \_\_\_\_\_

Print Name: \_\_\_\_\_ Title: \_\_\_\_\_

\_\_\_\_\_  
*Signature*

\_\_\_\_\_  
*Date Signed*

**Guidelines for Evaluating Contractor  
Health & Safety Performance Programs**

This evaluation provides audited information on the contractor's safety program elements. Conclusions about effectiveness of the safety program based on this audit are up to the facility.

Contract Company: \_\_\_\_\_ Phone: (\_\_\_\_) \_\_\_\_\_

Address: \_\_\_\_\_

City \_\_\_\_\_ State: \_\_\_\_\_ Zip: \_\_\_\_\_

Person Contacted: \_\_\_\_\_ Title: \_\_\_\_\_

-----

Evaluated by: \_\_\_\_\_ Company: \_\_\_\_\_

\_\_\_\_\_  
*Signature*

\_\_\_\_\_  
*Date*

-----

**Mark One  
Yes or No**

**1. The written safety policy endorsed by the contractor's top management**

- |     |   |                          |                          |
|-----|---|--------------------------|--------------------------|
| 1.1 | Does the contractor at the corporate or local level have a written policy statement reflecting management's commitment to safety and health? (If no proceed to 2.1) | <input type="checkbox"/> | <input type="checkbox"/> |
| 1.2 | Is the general policy statement signed by the general operating manager?  | <input type="checkbox"/> | <input type="checkbox"/> |
| 1.3 | Does the general policy statement contain:  |                          |                          |
|     | a) Injury to personnel?   | <input type="checkbox"/> | <input type="checkbox"/> |
|     | b) Damage to property?  | <input type="checkbox"/> | <input type="checkbox"/> |
|     | c) Control of occupational health?  | <input type="checkbox"/> | <input type="checkbox"/> |
|     | d) Control of fire?   | <input type="checkbox"/> | <input type="checkbox"/> |
|     | e) Compliance with legislation?   | <input type="checkbox"/> | <input type="checkbox"/> |

## Safety Procedure 5 Contractor Safety Requirements

		Mark One Yes or No	
1.4	Has the general policy statement been:		
	a) Contained in manuals?	<input type="checkbox"/>	<input type="checkbox"/>
	b) Posted in different areas?	<input type="checkbox"/>	<input type="checkbox"/>
	c) Listed in all rule booklets?	<input type="checkbox"/>	<input type="checkbox"/>
	d) Used in major training programs?	<input type="checkbox"/>	<input type="checkbox"/>
	e) Used in other ways	<input type="checkbox"/>	<input type="checkbox"/>
2.	<b>A staffing plan (Who's responsible for the contractor's safety and job site program implementation?)</b>		
2.1	Are each manager's responsibilities for the safety and health defined in writing?	<input type="checkbox"/>	<input type="checkbox"/>
2.2	Is there documentation to support that employees have been informed of their responsibility to report hazards to their immediate supervisor?	<input type="checkbox"/>	<input type="checkbox"/>
2.3	Is there a written follow-up procedure for appropriate personnel to follow for dealing with the hazards reported by employees?	<input type="checkbox"/>	<input type="checkbox"/>
3.	<b>How are on-site managers and supervisors held accountable for safety and job performance?</b>		
3.1	Have management personnel been evaluated on a yearly basis to determine their performance in safety and health?	<input type="checkbox"/>	<input type="checkbox"/>
4.	<b>Does the contractor have a safety manager?</b>		
4.1	Does the contractor have a person assigned to safety and health?	<input type="checkbox"/>	<input type="checkbox"/>
4.2	Does the contractor's safety manager report directly to the contractor foreman?	<input type="checkbox"/>	<input type="checkbox"/>
4.3	Is an adequate amount of the contract safety manager's time devoted exclusively to safety?	<input type="checkbox"/>	<input type="checkbox"/>
4.4	Does the contractor have an adequately staffed safety group?	<input type="checkbox"/>	<input type="checkbox"/>
5.	<b>The contractor's Safety and Health programs and procedures</b>		
5.1	Are the following work programs and/or procedures in writing?		
	a) PPE Program	<input type="checkbox"/>	<input type="checkbox"/>
	b) Powered industrial vehicles (cranes, forktrucks man lifts, etc.)	<input type="checkbox"/>	<input type="checkbox"/>
	c) Emergency Preparedness	<input type="checkbox"/>	<input type="checkbox"/>

Safety Procedure 5  
Contractor Safety Requirements

	Mark One Yes or No	
d) Rigging and Lifting safety	<input type="checkbox"/>	<input type="checkbox"/>
e) Written General Safety & Health Rules	<input type="checkbox"/>	<input type="checkbox"/>
f) Confined Space Program	<input type="checkbox"/>	<input type="checkbox"/>
g) Blood borne Pathogens Program	<input type="checkbox"/>	<input type="checkbox"/>
5.2 Are the contractor's safety & health programs and procedures available to all employees?	<input type="checkbox"/>	<input type="checkbox"/>
<b>6. The contractor's incident investigation program</b>		
6.1 Does the contractor have an incident investigation program? (if no, proceed to section 7.)	<input type="checkbox"/>	<input type="checkbox"/>
6.2 Are the contractors line supervisors included in the reporting and investigations of incidents?	<input type="checkbox"/>	<input type="checkbox"/>
6.3 Does the contractor have a standard form for investigating incidents? (If no proceed to 6.6)	<input type="checkbox"/>	<input type="checkbox"/>
6.4 Does the investigation form lead the investigator to consider the basic causes and the substandard acts or conditions?	<input type="checkbox"/>	<input type="checkbox"/>
6.5 Are the investigators encouraged to report the major areas (description/causes/ analysis/remedial action) by enough writing space on the form?	<input type="checkbox"/>	<input type="checkbox"/>
6.6 Determine if the incident requires an investigation by the supervisor for the following items:		
a) All non-disabling injuries or illnesses	<input type="checkbox"/>	<input type="checkbox"/>
b) Fatalities	<input type="checkbox"/>	<input type="checkbox"/>
c) Fire and/or explosions	<input type="checkbox"/>	<input type="checkbox"/>
d) Property damage at or above an estimated cost base	<input type="checkbox"/>	<input type="checkbox"/>
e) Hazardous substance discharges and other related incidents	<input type="checkbox"/>	<input type="checkbox"/>
f) Other incidents (near misses)	<input type="checkbox"/>	<input type="checkbox"/>
6.7 Does the contractor have a written procedure which ensures that remedial actions are carried out as recommended in the investigation report? (If no proceed to 6.9)	<input type="checkbox"/>	<input type="checkbox"/>
6.8 Does the contractor require remedial actions be to be checked off on an item for item basis when actions are completed?	<input type="checkbox"/>	<input type="checkbox"/>
6.9 Does the contractor maintain records of incident investigation reports?	<input type="checkbox"/>	<input type="checkbox"/>



Mark One  
Yes or No

**7. Contractor's disciplinary action procedures that address safety and job related infractions**

- 7.1 Does the contractor have a written disciplinary policy to be used as a guide in dealing with violators of safety and other work related rules?
- 7.2 Has the contractor's disciplinary policy been communicated to all employees?

**8. The contractor's medical program**

- 8.1 Does the contractor perform:
- a) Annual audiometric exams
  - b) Annual crane physicals
  - c) Annual DOT physicals
- 8.2 Does the contractor have a written substance abuse program which includes the following:
- a) Pre-employment testing
  - b) Post accident testing
  - c) Random testing
  - d) Testing for cause
  - e) Return to duty testing
  - f) Auditing by an independent body

**9. Respiratory protection program**

- 9.1 Has a written respiratory protection program been developed and implemented?
- 9.2 Does the written program address the following elements?
- a) Respirators are appropriate for the contaminant(s) present in the work place
  - b) Respirator type is determined by a qualified individual. Personal air monitoring data is reviewed to ensure that appropriate respirator type is in use.
  - c) Written operating procedures governing the selection and use of respirators are available.
- 9.3 Does the contractor ensure that all negative pressure respirator wearers are fit-tested with the devices they will wear?
- What method \_\_\_\_\_ Qualitative \_\_\_\_\_ Quantitative

## Safety Procedure 5 Contractor Safety Requirements

		<b>Mark One Yes or No</b>	
9.4	Does the contractor have a policy in place concerning facial hair and the use of respirators?	<input type="checkbox"/>	<input type="checkbox"/>
9.5	Does the contractor train employees annually in the proper use and maintenance of the respirator being used?	<input type="checkbox"/>	<input type="checkbox"/>
9.6	Does the contractor have a qualified person conduct random inspections to assure respirators are properly selected, used, cleaned and maintained?	<input type="checkbox"/>	<input type="checkbox"/>
9.7	Does the contractor annually confirm by a medical screening that employees who wear respirators are able to perform work while using a respirator?	<input type="checkbox"/>	<input type="checkbox"/>
<b>10. Hazcom program</b>			
10.1	Has a written HAZ-COM program been developed and implemented? (if no, proceed to section 11)	<input type="checkbox"/>	<input type="checkbox"/>
10.2	Does the written program address the following elements?		
	a) Guidelines or methods to inform employees of hazards associated with chemicals used during non-routine tasks	<input type="checkbox"/>	<input type="checkbox"/>
	b) The methods used to inform employees of chemical hazards encountered in the multi-employer work site where other employers are using chemicals in the same work area	<input type="checkbox"/>	<input type="checkbox"/>
	c) Guidelines to ensure that the written program is available to employees or their designated representative	<input type="checkbox"/>	<input type="checkbox"/>
	d) Procedures to ensure that all containers of hazardous chemicals are properly labeled or tagged	<input type="checkbox"/>	<input type="checkbox"/>
	e) Procedures to ensure that all material safety data sheets are maintained for each hazardous chemical	<input type="checkbox"/>	<input type="checkbox"/>
	f) Procedures to ensure that employees are provided with information and training on hazardous chemicals when they are introduced to the work place	<input type="checkbox"/>	<input type="checkbox"/>
<b>11. Hearing conservation program</b>			
11.1	Has a written hearing conservation program been developed and implemented? (If no, proceed to section 12)	<input type="checkbox"/>	<input type="checkbox"/>
11.2	Have exposed or potentially exposed employees been identified via personal noise monitoring for inclusion into the hearing conservation program?	<input type="checkbox"/>	<input type="checkbox"/>

## Safety Procedure 5 Contractor Safety Requirements

		<b>Mark One Yes or No</b>	
11.3	Does the contractor have an established audiometric testing program for all employees that may be at risk of exposure?	<input type="checkbox"/>	<input type="checkbox"/>
11.4	Does the contractor provide hearing protection for all employees exposed?	<input type="checkbox"/>	<input type="checkbox"/>
11.5	Does the contractor train employees annually for the following:		
	a) Effects of noise on hearing	<input type="checkbox"/>	<input type="checkbox"/>
	b) Purpose of hearing protection	<input type="checkbox"/>	<input type="checkbox"/>
	c) Instruction on proper selection, use and care of hearing protection	<input type="checkbox"/>	<input type="checkbox"/>
	d) Purpose of hearing protection	<input type="checkbox"/>	<input type="checkbox"/>
<b>12. Contractor safety meetings</b>			
12.1	Do all employees attend safety meetings at least monthly?	<input type="checkbox"/>	<input type="checkbox"/>
12.2	Does the contractor have a written procedure being followed to ensure the follow-up of items reported during safety meetings?	<input type="checkbox"/>	<input type="checkbox"/>
12.3	Does the contractor maintain records that indicate when safety meetings were held, who was present, and who conducted them?	<input type="checkbox"/>	<input type="checkbox"/>
12.4	Do the contractor's records of safety meetings indicate the specific subject(s) of the meeting?	<input type="checkbox"/>	<input type="checkbox"/>
12.5	Does the contractor's middle management actively participate in at least two safety meetings with all of their employees each year?	<input type="checkbox"/>	<input type="checkbox"/>
<b>13. Contractor training program</b>			
13.1	Does the contractor provide or ensure appropriate job skills training?	<input type="checkbox"/>	<input type="checkbox"/>
13.2	Does the contractor maintain skills training records or job qualifications that pertain to each employee's job task?	<input type="checkbox"/>	<input type="checkbox"/>
13.3	Does the contractor test employees to determine efficiency of job performance training?	<input type="checkbox"/>	<input type="checkbox"/>
13.4	Do the training records contain the employee's name and date of training?	<input type="checkbox"/>	<input type="checkbox"/>
13.5	Do contractor employees receive basic maintenance training covering subjects such as hand tools, measurement tools, and power tools?	<input type="checkbox"/>	<input type="checkbox"/>
13.6	Does the new contractor perform an initial, formal job orientation for new and transferred employees?	<input type="checkbox"/>	<input type="checkbox"/>

Safety Procedure 5  
Contractor Safety Requirements

	<b>Mark One Yes or No</b>	
13.7 Which of the following subjects are covered in the orientation of new and transferred employees?		
a) Safety policies and rules	<input type="checkbox"/>	<input type="checkbox"/>
b) Safe work practices	<input type="checkbox"/>	<input type="checkbox"/>
c) Safety Meetings	<input type="checkbox"/>	<input type="checkbox"/>
13.8 Does the contractor maintain a signed receipt of the rules, along with evidence that rules have been reviewed with each employee?	<input type="checkbox"/>	<input type="checkbox"/>
13.9 Does the contractor have a specific health and safety training program for supervisors?	<input type="checkbox"/>	<input type="checkbox"/>
13.10 What industrial safety & health training do employees receive?	<input type="checkbox"/>	<input type="checkbox"/>
<b>14. Contractor safety incentive program</b>		
14.1 Do individual contractor employees receive recognition or awards based on their contribution to the safety program?	<input type="checkbox"/>	<input type="checkbox"/>
<b>15. How do contractor's safety programs apply to subcontractors?</b>		
15.1 Are the subcontractor's minimum safety program requirements contained in initial bid documents as contracts?	<input type="checkbox"/>	<input type="checkbox"/>
15.2 Do subcontractor selection procedures include:		
a) Review of the subcontractor's existing safety and health programs prior to awarding the contract?	<input type="checkbox"/>	<input type="checkbox"/>
b) Review of the subcontractor's previous loss experience data?	<input type="checkbox"/>	<input type="checkbox"/>
15.3 Are pre-job meetings held between the contractor and the subcontractor company to review the company's safety program requirements and to designate a contact person for contractor program coordination?	<input type="checkbox"/>	<input type="checkbox"/>
15.4 Are the following reports forwarded to contractor company personnel to monitor the subcontractors safety program?		
a) Incident investigation reports	<input type="checkbox"/>	<input type="checkbox"/>
b) General inspection reports	<input type="checkbox"/>	<input type="checkbox"/>
c) Outside agencies reports	<input type="checkbox"/>	<input type="checkbox"/>
d) Loss data; i.e., injury and illness rate	<input type="checkbox"/>	<input type="checkbox"/>
e) Records of safety committee meetings	<input type="checkbox"/>	<input type="checkbox"/>

Safety Procedure 5  
Contractor Safety Requirements

Mark One  
Yes or No

**16. Lockout / Tagout**

- 16.1 Has a written lockout/tagout program been developed and implemented and is there documentation supporting implementation?
- 16.2 Is there a lock, tag and try procedure for each type of energy source? (i.e., electrical, mechanical, pressurized systems, etc.)
- 16.4 Does the contractor train affected employees in the following?
  - a) Recognition of hazardous energy sources.
  - b) Types of energy sources in the work place.
  - c) Methods and means necessary for energy isolation and control.
  - d) The purpose and use of energy control procedures.

**17. Fall protection**

- 17.1 Has a written fall protection program been developed and implemented?
- 17.2 Are employees trained on the use and types of fall protection provided?

**18. Contract company injury/illness history for last 3 years**

18.1 What is the OSHA recordable injury rate the last 3 years?

$$\frac{\text{\#OSHA recordable accidents} \times 200,000 \text{ man hours}}{\text{total annual man hours}}$$

Year	Injury Rate
20____	_____
20____	_____
20____	_____

18.2 What is the lost time accident severity rate for the last 3 years?

$$\frac{\text{\#OSHA recordable accidents resulting in lost work time} \times 200,000 \text{ man hours}}{\text{total annual man hours}}$$

Year	Injury Rate
20____	_____
20____	_____
20____	_____

Mark One  
Yes or No

19. **Competent person on site**

- |      |   |                          |                          |
|------|---|--------------------------|--------------------------|
| 19.1 | Does the Contractor maintain at least one competent person on site to meet OSHA 29 CFR1926 competent person inspection and surveillance requirements when applicable? | <input type="checkbox"/> | <input type="checkbox"/> |
| 19.2 | Are contractor employees trained by a person qualified in the subject matter to recognize hazards associated with the following:                                      |                          |                          |
|      | a) Scaffold being used and procedures to control or minimize hazards related to the scaffold  | <input type="checkbox"/> | <input type="checkbox"/> |
|      | b) Ladders  | <input type="checkbox"/> | <input type="checkbox"/> |
|      | c) Lead   | <input type="checkbox"/> | <input type="checkbox"/> |
|      | d) Hearing protection   | <input type="checkbox"/> | <input type="checkbox"/> |
|      | e) Respiratory protection   | <input type="checkbox"/> | <input type="checkbox"/> |
|      | f) Welding, cutting and heating   | <input type="checkbox"/> | <input type="checkbox"/> |
|      | g) Fall protection  | <input type="checkbox"/> | <input type="checkbox"/> |
|      | h) Cranes and derricks  | <input type="checkbox"/> | <input type="checkbox"/> |
|      | i) Bolting, riveting, fitting-up, and plumbing-up   | <input type="checkbox"/> | <input type="checkbox"/> |
|      | j) Compressed air   | <input type="checkbox"/> | <input type="checkbox"/> |
|      | k) Blasting and use of explosives   | <input type="checkbox"/> | <input type="checkbox"/> |
|      | l) Cadmium  | <input type="checkbox"/> | <input type="checkbox"/> |

**Contractor Briefing  
Contractor Pre-Job Checklist**

Contractor Name: \_\_\_\_\_

Date: \_\_\_\_/\_\_\_\_/\_\_\_\_

**I. General Safety Procedures**

- Entering Facility
- Protective Work Clothing
- Housekeeping
- Personal Hygiene Practices
- Change Rooms
- Administrative Areas
- Hearing Protection (NRR $\geq$ 27)
- Eye Protection
- Fire Alarms/Evacuation
- Fire Prevention
- Clearance and Locking Procedures
- Confined Space Entry
- First Aid Locations
- Hot Work
- Hazard Communication (HAZCOM)
- Compressed Gas
- Blood borne Pathogens
- Chemical Processes
- Furnace/Boiler Entry
- Fall Protection
- Scaffolding
- Blast Cleaning Procedures
- Radiation detectors
- Electrical Safety

**II. Worker Conduct**

- General Facility Rules
- Sexual Harassment

**III. Heavy Metal Exposure**

- Exposure to Lead/Arsenic/Cadmium
- Federal Regulations
- Protective Overalls
- Showers

**IV. Respiratory Protection**

- Respirator Selection
- Respiratory Fit Testing
- Respirator Types
- Respirator Selection Guide
  
- Appendix A - Eye Protection Requirements
- Appendix B - Contractor Respirator Selection Guidance
- Appendix C - Fire and Emergency Response or Action Plan
- Appendix D - Smoking Policy
- Appendix E - Facial Hair Policy
- Appendix F - Other Site-Specific Requirements
- Appendix G - Contractor Safety Violation Notification Form





**EXHIBIT H**  
**(NOT USED)**

**EXHIBIT I**

**RATES FOR TIME AND MATERIAL WORK**

PROPOSAL SCHEDULE V

OPTION FOR ADDITIONS OR DELETIONS

There are three methods for changing (additions or deletions) the Contract Price. They are (i) Lump Sum method, (ii) Not-To-Exceed method, (iii) Time and Material method. The preferred method is Lump Sum. The method allowed for an individual change shall be as agreed upon by the Purchaser prior to making the change. In all three cases the Contractor is required to submit a price breakdown demonstrating the markups below or actual cost plus the markup below. The rates and markups provided herein shall be utilized to quantify and/or justify the Contractor pricing for any change.

The direct cost of changes (additions or deletions) to the Contract Price authorized by Purchaser, shall be computed based on actual and reasonable material costs and the fair and reasonable cost of labor consistent with the scope of work and accepted industry practice and the completed labor rate schedule attached hereto.

The cost of overhead and profit to be applied to additions or deletions shall be as provided below. Both parties agree that the percentage multipliers for overhead and profit shall be applied to the net labor and material costs for each change summarized at the first tier subcontractor level only.

PERCENTAGE MULTIPLIERS

Contractor shall use the following percentage multipliers to reflect markups for overhead and profit on changes authorized by Purchaser. Markups shall be applied to the reasonable direct cost which do not include any Contractor percentage margin for overhead and profit. The markups shall be used to compute the total cost of the change. The following definitions apply.

Direct Cost Any cost that is specifically identified with a final cost objective such as labor, material and equipment, but not to include minor efforts such as drawing reproduction or proposal preparations.

Overhead Any indirect cost not directly identified with a single final cost objective. Contractor's main office overhead, job office overhead, liability and auto insurance, field engineering and superintendence at indirect costs. Minor efforts such as proposal preparation, drawing production, as-builts, clean-up and additional bonding cost are to be included in the overhead rate.

- A. A percentage multiplier for OH & P shall be ~~30~~<sup>15%</sup> % on added work and 0% on deleted work, directly performed by contractor's own force. DD
- B. Percentage multiplier for OH & P shall be ~~40~~<sup>20%</sup> % (Contractor and subcontractor combined) on added work and 0% on deleted work, performed by Contractor forces (at any tier). DD

NOTE: The Overhead and Profit percentage is calculated utilizing the "Base Rate" as identified in the Labor Rate schedule

**TAMPA TANK, INC.**  
**FIELD LABOR RATES - TO December 31, 2005**

<b>Worker Classification</b>	<b>BASIS</b>	<b>FOREMAN</b>	<b>PUSHER</b>	<b>WELDER</b>	<b>WELDR II</b>	<b>LABORER</b>
Wage Rate - Straight Time		\$25.75	\$20.25	\$19.75	\$17.75	\$13.50
FICA	0.0765	\$1.97	\$1.55	\$1.51	\$1.36	\$1.03
Fed Un-Comp	0.0080	\$0.21	\$0.16	\$0.16	\$0.14	\$0.11
State Un-Comp	0.0040	\$0.10	\$0.08	\$0.08	\$0.07	\$0.05
Worker's Comp	0.2501	\$6.44	\$5.06	\$4.94	\$4.44	\$3.38
Group Insurance	\$3.00	\$3.00	\$3.00	\$3.00	\$3.00	\$3.00
Subsistence	\$6.00	\$6.00	\$6.00	\$6.00	\$6.00	\$6.00
Supt. Expenses	\$1.40	\$1.40	\$1.40	\$1.40	\$1.40	\$1.40
Truck Allowance	\$0.80	\$0.80	\$0.80	\$0.80	\$0.80	\$0.80
Fuel	\$1.75	\$1.75	\$1.75	\$1.75	\$1.75	\$1.75
Field Supplies	\$3.50	\$3.50	\$3.50	\$3.50	\$3.50	\$3.50
Toolhouse/Small Tools	\$0.50	\$0.50	\$0.50	\$0.50	\$0.50	\$0.50
Overhead	\$8.00	\$8.00	\$8.00	\$8.00	\$8.00	\$8.00
Weld Rod	\$2.00	\$2.00	\$2.00	\$2.00	\$2.00	\$2.00
Cost		\$61.42	\$54.06	\$53.39	\$50.71	\$45.02
Profit	10%	\$6.14	\$5.41	\$5.34	\$5.07	\$4.50
<b>Hourly Rate, ST</b>		<b>\$67.56</b>	<b>\$59.46</b>	<b>\$58.73</b>	<b>\$55.78</b>	<b>\$49.52</b>

<b>Worker Classification</b>	<b>BASIS</b>	<b>FOREMAN</b>	<b>PUSHER</b>	<b>WELDER</b>	<b>HELPER</b>	<b>LABORER</b>
Wage Rate - Overtime		\$38.63	\$30.38	\$29.63	\$26.63	\$20.25
FICA	0.0765	\$2.95	\$2.32	\$2.27	\$2.04	\$1.55
Fed Un-Comp	0.0080	\$0.31	\$0.24	\$0.24	\$0.21	\$0.16
State Un-Comp	0.0040	\$0.15	\$0.12	\$0.12	\$0.11	\$0.08
Worker's Comp	0.2501	\$9.66	\$7.60	\$7.41	\$6.66	\$5.06
Group Insurance	\$3.00	\$3.00	\$3.00	\$3.00	\$3.00	\$3.00
Subsistence	\$6.00	\$6.00	\$6.00	\$6.00	\$6.00	\$6.00
Supt. Expenses	\$1.25	\$1.25	\$1.25	\$1.25	\$1.25	\$1.25
Truck Allowance	\$0.75	\$0.75	\$0.75	\$0.75	\$0.75	\$0.75
Fuel	\$1.75	\$1.75	\$1.75	\$1.75	\$1.75	\$1.75
Field Supplies	\$3.50	\$3.50	\$3.50	\$3.50	\$3.50	\$3.50
Toolhouse/Small Tools	\$0.50	\$0.50	\$0.50	\$0.50	\$0.50	\$0.50
Overhead	\$8.00	\$8.00	\$8.00	\$8.00	\$8.00	\$8.00
Weld Rod	\$2.00	\$2.00	\$2.00	\$2.00	\$2.00	\$2.00
Cost		\$78.45	\$67.41	\$66.41	\$62.39	\$53.86
Profit	10%	\$7.85	\$6.74	\$6.64	\$6.24	\$5.39
<b>Hourly Rate, OT</b>		<b>\$86.30</b>	<b>\$74.15</b>	<b>\$73.05</b>	<b>\$68.63</b>	<b>\$59.24</b>

<b>Overtime Premium</b>		<b>\$18.74</b>	<b>\$14.69</b>	<b>\$14.32</b>	<b>\$12.85</b>	<b>\$9.72</b>
-------------------------	--	----------------	----------------	----------------	----------------	---------------

Because Tampa Tank works in a wide variety of places where wage rates can vary from \$2.00 per hour to \$35.00 per hour, it is not practical to determine overhead rates as a percentage of wage rates. We offer for your consideration, the above rates, which are calculated on the basis of dollars per manhour.

# TAMPA TANK, INC.

## CONSTRUCTION EQUIPMENT RENTAL RATES

Valid thru December 31, 2005

DESCRIPTION	HOURLY	DAILY	WEEKLY	MONTHLY
18 Ton Cherrypicker	\$130.95	\$523.81	\$1,833.33	\$5,500.00
250 amp Diesel Welder	\$19.05	\$76.19	\$266.67	\$800.00
400 Amp Rectifier	\$7.14	\$28.57	\$100.00	\$300.00
Power Panel	\$7.14	\$28.57	\$100.00	\$300.00
125 cfm Diesel Compressor	\$50.00	\$200.00	\$700.00	\$2,100.00
Bobcat	\$59.52	\$238.10	\$833.33	\$2,500.00
100 cfm Electric Compressor	\$33.33	\$133.33	\$466.67	\$1,400.00
200 kw Diesel Generator	\$66.67	\$266.67	\$933.33	\$2,800.00
Impact Wrench	\$1.71	\$6.86	\$24.00	\$72.00
Air Grinder	\$1.71	\$6.86	\$24.00	\$72.00
Burning Outfit	\$1.31	\$5.24	\$18.33	\$55.00
Come-a-long	\$1.71	\$6.86	\$24.00	\$72.00
50 Ton Jack	\$1.90	\$7.62	\$26.67	\$80.00
Air Tugger	\$7.62	\$30.48	\$106.67	\$320.00
Std Lifting Beam	\$5.95	\$23.81	\$83.33	\$250.00
Tank Scaffold / per Section	\$0.60	\$2.38	\$8.33	\$25.00
Key Plates	\$0.36	\$1.43	\$5.00	\$15.00
Welding Rod Oven	\$3.10	\$12.38	\$43.33	\$130.00
Welder's Cage	\$5.95	\$23.81	\$83.33	\$250.00
Personnel Cage	\$7.14	\$28.57	\$100.00	\$300.00

The above rates are for equipment owned by Tampa Tank. For Rented equipment, the rate will be actual costs plus 15%. The above rates do not include transportation of the equipment. This would be extra, if needed.

**EXHIBIT J**  
**APPROVED SUBCONTRACTORS AND VENDORS**

**Pop's Painting**

**Painting and Lining**

**EXHIBIT K**

**Lee County DM/DWBE Rules**

**(LATER)**

EXHIBIT L

(DELETED)



**EXHIBIT M**  
**FORM OF**  
**CONTRACTOR'S AFFIDAVIT,**  
**WAIVER OF LIENS**  
**AND**  
**GENERAL RELEASE**

STATE OF:

COUNTY OF:

The undersigned, \_\_\_\_\_ says that he is the \_\_\_\_\_ of \_\_\_\_\_ (hereinafter referred to as "Contractor") and that he is familiar with the facts herein stated.

The Contractor has furnished all of the designs, engineering, technology, services, materials, labor, tools, equipment, construction facilities required by the Contract and everything of every sort, and has performed all Work required by the Contract, the same having been entered into with County on the \_\_\_\_ day of \_\_\_\_\_, 20\_\_ pertaining to the \_\_\_\_\_ in Lee County, Florida.

Contractor certifies that it has fully paid or has made provision for payment for all technical services, materials, labor, tools, equipment, and construction facilities, and everything of every sort furnished by Contractor, or by its Subcontractors, vendors or materialmen, upon the premises and furnished for the Project.

Contractor agrees and undertakes to indemnify County and Covanta and their respective parents, Affiliate Companies, agents, successors, or assigns, including the officers, directors, officials and employees of the indemnitees affiliate companies and saved harmless at all times from and against any claims, demands, losses, damages, costs and expenses on any account whatsoever by any Subcontractor, vendor and materialman including but not limited to costs and charges for the goods, materials, fitments and equipments brought to the Site whether for incorporation in the Project including subcontract work or the execution thereof or otherwise or in regard to the services rendered for or towards the execution of the Work including Subcontractor work and from and against any negligence of the Contractor or Subcontractors or their agents, workmen, and servants and from and against any misuse by them of any construction plant or temporary works for the purposes of the execution of the Work including subcontract work.

In consideration of payments made, or to be made, Contractor for itself, its Subcontractors, suppliers and materialmen hereby waives and releases any and all liens, lien rights and claims whatsoever, whether known or unknown against the Project, Existing Facility, County, Covanta and their successors and assigns, and their premises or property with respect to Contractor's Work other than such claims, if any, that may (with the consent of County) be specifically excepted from the terms of this Affidavit/Waiver and Release.

Contractor represents that no other person or party has any right to a lien, claim or charge on account of any Work performed or for material furnished to Contractor for the Work and agrees to indemnify and hold harmless the releasees from any and all claims or demands of laborers, Subcontractors, materialmen and suppliers of Contractor.

This Affidavit, Waiver and Release does not relieve Contractor from any of its continuing indemnity, confidentiality, warranty and guaranty obligations, either directly or derivatively through its Contract with County, or under any other Contract provision intended to survive completion of Contractor's Work or termination thereof.

By:

Title:

Date:

Sworn to me and subscribed in my  
Presence this \_\_\_\_ day of \_\_\_\_\_,  
20\_\_

Notary Public

My commissions expires:

LEE COUNTY CONSTRUCTION CONTRACT  
PUBLIC PAYMENT AND PERFORMANCE BOND

1. Know all men by these presents, that Contractor Name, Address, Phone Number, hereinafter referred to as the CONTRACTOR, as Principal, and a corporation, licensed to do business in the State of Florida, hereinafter called SURETY, located at: \_\_\_\_\_

\_\_\_\_\_, are held and firmly bound unto the Lee County Board of County Commissioners, P O Box 398, Fort Myers, FL 33901, (239) 335-2183, a Political Subdivision of the State of Florida as "Owner", in the full and just sum of (Amount in Words)

( \_\_\_\_\_ ) Dollars, lawful money of the United States of America, to the payment of which sum, will and truly to be made, the CONTRACTOR and SURETY bind themselves, their representatives, and each of their heirs, executors, administrators, successors and assigns, jointly and severally, firmly by these presents.

2. WHEREAS, the CONTRACTOR has entered into a certain written Contract with the COUNTY as the OWNER, dated the \_\_\_ day of \_\_\_\_\_, for: Legal Description of project, - **STRAP**, whose address is \_\_\_\_\_ for the project known as \_\_\_\_\_

with conditions and provisions as are further described in 'the aforementioned Contract, which Contract is by reference made a part hereof in its' entirety for the purpose of perfecting this bond.

3. NOW, THEREFORE, the conditions of this obligation are such that if CONTRACTOR shall fully, promptly and faithfully perform said Contract and all obligations thereunder, including all obligations imposed by the Contract Documents (which includes the Notice to Bidders, Instruction to Bidders, Bid Proposal Form, General and Supplementary Conditions, Detail Specifications, Form(s) of Contract Bond(s), Plans and Specifications, Change Orders, and such alterations thereof as may be made as provided for therein), and shall promptly make payments to all claimants for any and all labor and materials used or reasonably required for use or furnished in connection with the performance of said Contract, and shall perform all other covenants and obligations of this bond, then this obligation shall be void; otherwise it shall remain in full force and effect.

3.1 The undersigned shall indemnify and save harmless the OWNER from and against all costs, expenses and damages, including litigation costs and attorneys fees arising out of, or in connection with the neglect, default or want of care or skill, including patent infringement on the part of said CONTRACTOR, his agents, servants or employees in the execution or performance of said Contract with the OWNER.

3.2 The undersigned shall promptly make payment(s) to all persons supplying services, labor, material or supplies used directly or indirectly by said CONTRACTOR, or any SubContractor or Sub-SubContractor, in the prosecution of the work provided for in said Contract with the OWNER.

CONSTRUCTION CONTRACT  
PUBLIC PAYMENT AND PERFORMANCE BOND (CONTINUED)

3.3 The undersigned agree to promptly pay to the OWNER any difference between the sum to which the CONTRACTOR would be entitled for the completion of the contract including any damages, direct, liquidated or delay, which the OWNER may sustain by reason of failure of the CONTRACTOR to properly and promptly perform and abide by all of the provisions of said Contract, and any sum which the OWNER may be or was obligated to pay for the completion of said Work by the CONTRACTOR.

3.4 The undersigned SURETY covenants and agrees that change orders, extensions of time, alterations or additions to the terms of the Contract or the Work to be performed thereunder, or the specifications accompanying the same shall in no way effect their obligation on this Bond, and the SURETY does hereby expressly waive notice of any such changes, extensions of time, alterations or additions, so long as the fundamental nature of the work on the Project by the CONTRACTOR is not changed.

3.5 Subject to the OWNER'S priority, claimants covered by Section 713.01, Florida Statutes, shall have a direct right of action against the Principal and Surety under this obligation, after written notice is provided to the OWNER of the performance of labor or delivery of materials or supplies, and non-payment thereof. Any claimant who seeks to recover against the Principal or Surety under this obligation must also satisfy the notice requirements and time limitations of Section 255.05, Florida Statutes, as they may be revised from time to time.

4.1 The CONTRACTOR and the SURETY shall hold the County harmless from any and all damages, expenses and cost, or lawsuits, which may arise by virtue of any defects in said work or materials within the period of one (1) year from the date of OWNER'S express acceptance of the project, providing, however, that upon completion of the Work, the amount of this bond shall be reduced to \_\_\_% of the Contract Price.

5.1 This public payment and performance bond shall be governed by the laws, administrative rules, and regulations of the State of Florida. Any claims or suits instituted under this bond shall be governed solely by the laws of the State of Florida.

SIGNED and sealed this, the \_\_\_\_\_ day of \_\_\_\_\_, 2005

CONTRACTOR, As Principal:

WITNESS

\_\_\_\_\_  
Firm Name

\_\_\_\_\_  
Signature

By:

\_\_\_\_\_  
(SEAL)

\_\_\_\_\_  
Signature

\_\_\_\_\_  
Type Name and Title

\_\_\_\_\_  
Type Name and Title

WITNESS: (if no Seal)

\_\_\_\_\_  
Signature

\_\_\_\_\_  
Type Name and Title

CONSTRUCTION CONTRACT  
PUBLIC PAYMENT AND PERFORMANCE BOND (CONTINUED)

COUNTERSIGNED, as SURETY

Title \_\_\_\_\_

STATE OF \_\_\_\_\_ )  
COUNTY OF \_\_\_\_\_ ) SS  
CITY OF \_\_\_\_\_ )

Name \_\_\_\_\_

Address \_\_\_\_\_

City, State, Zip Code \_\_\_\_\_

Power-of-Attorney Signature \_\_\_\_\_

BEFORE me, a Notary Public, duly commissioned, qualified and acting personally, appeared:

\_\_\_\_\_  
\_\_\_\_\_

to me well-known, who being by me first duly sworn upon oath says that he is Attorney-in-Fact for \_\_\_\_\_, as Surety, and that he has been authorized by said Surety to execute the foregoing Public Payment and Performance Bond on behalf of the (CONTRACTOR) Principal named therein in favor of the OWNER.

The foregoing instrument was signed and acknowledged before me this \_\_\_\_\_ day of \_\_\_\_\_, 2005, by \_\_\_\_\_ (Print or Type Name) who has produced \_\_\_\_\_ (Type of Identification and Number) as identification.

Notary Public Signature \_\_\_\_\_

Printed Name of Notary Public \_\_\_\_\_

Notary Commission Number/Expiration \_\_\_\_\_