

**Lee County Board Of County Commissioners
Agenda Item Summary**

Blue Sheet No. 20061188

1. ACTION REQUESTED/PURPOSE: Approve Project # PB060717, the utilization (piggyback) of the Florida Department of Transportation-Public Transit Office Proposal # FVPP-03-SC-3 for the purchase of seven paratransit vehicles for Lee Tran. The vehicles will be purchased from Transit Plus, Inc. at a unit price of \$56,492 each, for a grand total of \$395,444 for seven vehicles. This purchase is 100% federally funded by Federal Transit Administration.

2. WHAT ACTION ACCOMPLISHES: Allows Lee Tran to replace seven (7) aging vehicles in the Lee Tran fleet.

3. MANAGEMENT RECOMMENDATION: Approve as stated.

4. Departmental Category: 6 C6C **5. Meeting Date:** SEP 26 2006

6. Agenda: <input checked="" type="checkbox"/> Consent <input type="checkbox"/> Administrative <input type="checkbox"/> Appeals <input type="checkbox"/> Public <input type="checkbox"/> Walk-On	7. Requirement/Purpose: (specify)		8. Request Initiated: Commissioner _____ Department _____ Division <u>Lee Tran</u> By: <u>Steve Myers</u>
	<input type="checkbox"/> Statute	_____	
	<input type="checkbox"/> Ordinance	_____	
	<input checked="" type="checkbox"/> Admin. Code	_____	
	<input type="checkbox"/> Other	_____	

9. Background: On September 6, 2006 the Purchasing Division received a request from Lee Tran to piggyback the Florida Department of Transportation-Public Transit Office's Proposal for the purchase of seven paratransit vehicles from Transit Plus, Inc. Funding will come from the individual division's budget and they will be responsible for monitoring their own expenditures.

Account String: KI5440148640.506430.08

ATTACHMENTS:

- (1) Division request to piggyback
- (2) Transit Plus, Inc. bid to FDOT-Public Transit Office
- (3) Award and order packet for Transit Plus, Inc.
- (4) FTA certifications

10. Review for Scheduling:

Department Director	Purchasing or Contracts	Human Resources	Other	County Attorney	Budget Services				County Manager/P.W. Director
					Analyst	Risk	Grants	Mgr.	
<i>Steve Myers</i> 9/7/06	<i>Jenifer Sheehan</i> 9-20-06			<i>S. A. Lewis</i> 9/17/06	<i>RK</i> 9/12	<i>wd</i> 9/12/06	<i>MP</i> 9/13/06	<i>MP</i> 9/13/06	<i>HS</i> 9/13/06

11. Commission Action:

- Approved
- Deferred
- Denied
- Other

RECEIVED BY COUNTY ADMIN:	<i>MP</i>
9/7/06 3:30 PM	
COUNTY ADMIN FORWARDED TO:	<i>MP</i>
9/14/06	
9 AM	

Rec. by CoAtty	
Date:	9/7/06
Time:	3:00 pm
Forwarded To:	County Admin
	9/14/06 3:15 pm

ATTACHMENT /**Jeffcoat, Chris R.**

From: Sheehan, Janet K.
Sent: Wednesday, September 06, 2006 8:21 AM
To: Jeffcoat, Chris R.
Cc: Riley, Susan P.; Franceschini, Robert D.
Subject: FW: Purchase of Seven Paratransit Vehicles from State Contract FVPP-03-5C-3
Attachments: ADA Seven Vehicle Replacement 2007.pdf

Chris,
Would you please handle?

Thanks,
Janet

From: Riley, Susan P.
Sent: Tuesday, September 05, 2006 5:52 PM
To: Sheehan, Janet K.
Cc: Myers, Steve L.; Ralston, Lawrence W.
Subject: Purchase of Seven Paratransit Vehicles from State Contract FVPP-03-5C-3

LeeTran needs to replace seven (7) aging paratransit vehicles in our fleet. We would like to purchase from the State Contract FVPP-03-5CX-3 at a price of \$56,492.00 per vehicle for a total amount of \$395,444.00. Attached is the specifications and contact information regarding the State Bid, Federal Certification Clauses and Vendor Information. LeeTran will need authorization from the BOCC for the purchase in the amount of \$395,444.00. This procurement is funded at 100% by the Federal Transit Administration and funds have been budgeted in FY07 K15440148640.506430.08 (Independent Division, Fixed Route, Transit Capital, Vehicle and Rolling Stock, ADA Paratransit Services).

Please let me know if you need any other information to proceed.

Thank you for your assistance with this procurement.

Susan Riley, Fiscal Manager
Lee County Transit
6035 Landing View Road
Ft. Myers, FL 33907
Phone 239-533-0331
Fax 239-277-5064

9/6/2006

ATTACHMENT 2

Florida Department of Transportation
Public Transit Office

Order Packet

ORDER FORM
FVPP-03-SC-3 (Small Cutaway Type Vehicles)
Transit Plus, Inc.

AGENCY NAME: LEE County TRANSIT DATE: 8-25-06 P.O.: _____

CONTACT PERSON: LARRY Ralston F.I.N.# _____

Feb 2006

Item	Cost	Quantity	Total Cost
Base Vehicle: Chevrolet 610/3500	\$44,967.00		\$44,967.00
Engine (Gasoline) Size: <u>6.0L</u> Make: <u>Chevy</u> Manufacturer: <u>Chevrolet</u>	Standard		
Engine (Diesel) Size: <u>6.6L</u> Make: <u>Duramax</u> Manufacturer: <u>Chevrolet</u>	\$4,799.00	1	\$4,799.00
Access Plate	\$0.00		
Stainless Steel Wheel Inserts	\$0.00		
Spare Tire/Wheel	\$0.00		
Seat Belt Extensions	\$12.00	2	\$24.00
Driver Seat A	\$445.00		
Driver Seat B	\$435.00		
Altro Flooring	\$814.00		
Public Address System	\$175.00		
AM/FM Radio	\$0.00		
TOTAL PAGE ONE			\$49,790.00

ORDER FORM (cont)

Item	Cost	Quantity	Total Cost
Help Bumpers Front	\$667.00		
Help Bumper Rear	\$411.00	1	\$411.00
Side Wheel chair lift (Braun L919IB)	\$3,367.00	1	\$3,367.00
Side Wheel chair lift (Ricon S-2005 and KlearView)	\$3,144.00		
Side Wheel chair lift (Maxon WL-6A3353)	\$3,480.00		
Rear Wheel chair lift (Ricon KlearView)	\$3,700.00		
Rear Wheel chair lift (Braun VL917IB)	\$3,700.00		
Sure-Lok restraint system (per position)	\$382.00		
Q-Straint restraint system (per position)	\$476.00		
Sure-Lok SoLo restraint system (per position)	\$550.00		
Q-Straint Slide Lock restraint system (per position)	\$522.00	2	\$1,044.00
Standard seat (per person)	\$179.00	8	\$1,432.00
Flip-Type seat (per person)	\$295.00		
Fold-Away seat (per person)	\$378.00		
Child seat (per person)	\$145.00		
Paint scheme 1	\$448.00	1	\$448.00
Paint scheme 2	\$448.00		
Paint scheme 3	\$448.00		
TOTAL (total page 2)			6,702.00
TOTAL (total page 1)			\$49,790.00
GRAND TOTAL (total page 1 and page 2)			\$56,492.00

8 D BATTERY = NO CHARGE
 PAINT WHEELS WHITE = NO CHARGE
 1 SPARE TIRE = NO CHARGE

CHOICES FORM

SEATING AND FLOORING CHOICES

Seating Colors: (circle one) gray blue tan
Flooring Colors: (circle one) gray blue tan black
Paint Scheme: (circle one) #1 #2 #3

Agencies will select two (2) colors for the background and stripe when orders are placed. If an agency requires a paint and lettering scheme that is NOT GENERALLY covered by one of those listed, they may make separate arrangements with Transit Plus, Inc. to provide these services. Base price reflects white base coat.

WHEELCHAIR LIFT CHOICES

Wheel Chair Lift: (circle one) SIDE: Braun Maxon Ricon
REAR: Ricon Braun

SECUREMENT DEVICE CHOICES

W/C securement (circle one) STANDARD: Sure-Lok Q'Straint
LOW-PROFILE: Sure-Lok Q'Straint

PLANNED SERVICE REQUIREMENT

Planned Usage (circle one) Fixed Route Demand Response

TWO-WAY RADIO WIRING SETUP

Radio works with (circle one) Ignition On Only Ignition On or Off

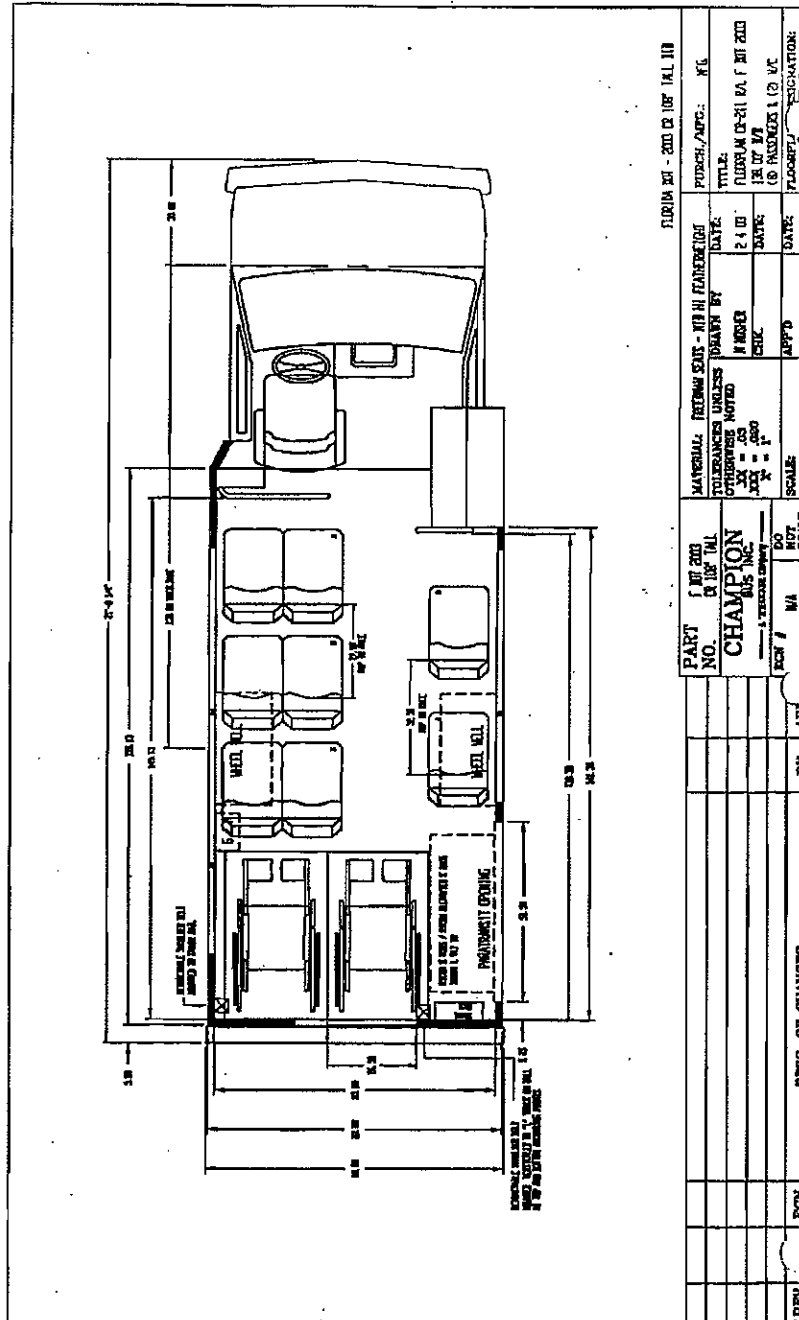

REV	DATE	BY	DESC. OF CHANGES	ECON	SCALE	DO SCALE

PART NO. 1 OF 101		MATERIAL: PREPARE DRAWING - NO. 101		FIGURE: 101	
CHAMPION BUS INC.		TOLERANCES UNLESS NOTED:		DATE: 2/4/03	
1 TUCKER DRIVE		FRAMES:		BY: J. J. J.	
CON	MA	SCALE	SCALE	DATE:	DATE:

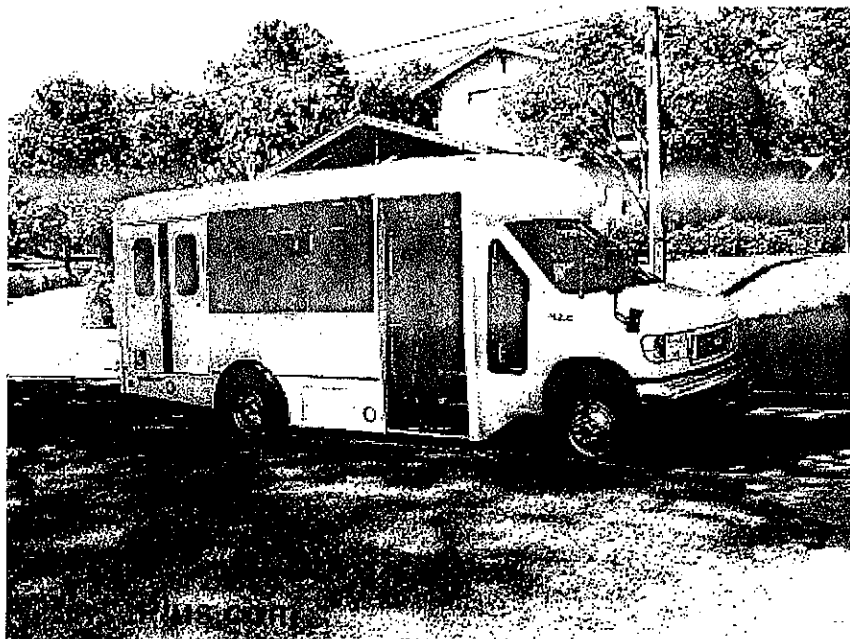

FVPP-03-SC-3 Small Cutaway Type Vehicles

General Information

The Florida Vehicle Procurement Program (FVPP) issued Proposal #FVPP-03-SC-3 to establish a state contract for the purchase of Small Cutaway Type Vehicles. Through this process, a contract was awarded to Transit Plus, Inc. on June 10, 2003 to provide these vehicles. This contract was then extended through the 2007 model year.

This packet contains the necessary instructions and forms for agencies to purchase vehicles. This information can also be found at the FVPP website (<http://www.cutr.usf.edu/fvpp>). This packet also provides guidance and clarity in the relationships between the buyers and the seller.

If an issue arises that is not adequately addressed, please contact Hank Cusack at (813) 974-7834 or Cindy Wooten at (813) 974-9771.

Vendor Information

Transit Plus, Inc. is located at 58 West 9th Street, Atlantic Beach, Fl. 32233. The telephone number is (904) 241-6004 and the FAX number is (904) 241-0507. When placing orders, please direct all inquiries to David Morris and reference the FVPP Contract # FVPP-03-SC-3.

Ordering, Delivery, and Payment

Procedures contained in this section will be used by agencies and vendors to provide guidance in the ordering of and payment for vehicles. Agencies should understand that each order placed with and acknowledged by Transit Plus, Inc. constitutes a contract between the purchaser and Transit Plus, Inc. only. The contract implies no duties or responsibilities by the Project Coordinator or the Florida Department of Transportation. The terms and conditions of the said contract are to be administered and enforced by and between the purchaser and bidder.

Ordering Instructions

An Agency Purchase Order should accompany all orders placed with Transit Plus, Inc. Please submit a separate order form (See Exhibit A – sample order form) for each vehicle. Each order form (See Exhibit B- actual order form) contains:

- The base vehicle price
- Seating and wheelchair station prices
- Paint scheme prices
- Individual option prices
- **Choices form**

The **Chevrolet** vehicle will be built on a dual rear wheel 610/3500 chassis with standard wheelbase. The vehicle will come standard with a 6.0L EFI V8 gasoline engine. All vehicles will have an electric door with standard driver's seat. The vehicle will also include the standard electrical system and all standard equipment and required options per the specifications.

Most agencies already have an idea of the type and number of seats/wheelchair stations needed to meet their floor plan requirements. Those agencies that have already determined their floor plan requirements should fax a copy of the proposed layout to Transit Plus, Inc. for verification prior to submitting their order(s). Agencies requiring assistance with floor plan layout should call Transit Plus, Inc. and discuss their needs. Transit Plus, Inc. will develop a proposed floor plan based on the agency's needs and fax a copy to the agency for verification prior to the agency submitting the order. A few sample floor plans are included with this packet.

Standard passenger seats will be Freedman Feather Weight Mid or High Back including a "Knee Saver" backrest design. Fold-a-way seats will be the Freedman BV 3-Step seat.

An illustration of the basic paint schemes (Exhibit C) and a description of the individual options (Exhibit D) are also being provided to assist you in compiling your order.

After determining a floor plan and the individual options, place the number of desired items in the quantity column. Multiply the dollar figure in the cost column by the number of items in the corresponding quantity column to arrive at a total cost per item. Enter the total in the total cost column. Add the figures in the total cost column to arrive at the grand total for the vehicle. The grand total will be the figure used on the agency's purchase order. Agencies may make as many copies as needed of the blank order form.

Transit Plus, Inc. will provide to the agency written confirmation of receipt of its order within 72 hours of receiving the order. At a minimum, the acknowledgment of order will contain:

- The agency's P.O. number
- Date order was received

- Date order was placed with the manufacturer
- The production / Vin number when available
- Estimated delivery date (when available)

Delivery

In case of delay in completion of delivery of an agency's vehicle(s) beyond the number of days allotted in the bid contract, the agency may assess as liquidated damage, \$25.00 per calendar day per vehicle (unless granted an extension in writing).

All work on and delivery of the vehicle(s) will be completed within ninety (90) days of receipt of chassis from the OEM supplier or receipt of Purchase Order from Purchaser, whichever occurs last. Each vehicle purchased through this contract shall be routed to the FDOT's Springhill inspection facility located in Tallahassee, Florida for an inspection prior to delivery to Transit Plus, Inc. Transit Plus, Inc. should see that all noted write-ups are corrected prior to final delivery to the procuring agency. This inspection by the FVPP is not represented as being "all inclusive" and in no way relieves the dealer from performing the required Pre-Delivery Inspection (PDI). Prior to the vehicle(s) being delivered, Transit Plus, Inc. must perform a PDI. Transit Plus, Inc. will notify the agency and the appropriate FDOT District Representative a minimum of 48 hours in advance to arrange a delivery time. Each vehicle will be delivered with all vendor/manufacturer's quality control checklist including road test and final inspection (properly completed and signed by an authorized plant representative). Other documents that Transit Plus, Inc. will provide at delivery include:

- Copy of Manufacture's Certificate of Origin.
- Copy of Application for Certificate of Title.
- Warranty papers (forms, policy, procedures).
- Maintenance manual.
- Spare key(s).
- Operator's manual.

Final Acceptance

A vehicle should be rejected if any of the above items are missing, defective, altered, incorrect, or incomplete. If a vehicle(s) is delivered incomplete or contains any defective or damaged parts, the said parts will be removed and replaced by Transit Plus, Inc. New parts will be furnished and installed by Transit Plus, Inc. at no cost to the agency. In the event work is involved, warranty or otherwise, to repair or place the vehicle(s) in proper complete condition, such repairs will be made by an approved firm (please see Exhibit F for warranty provisions).

Delivery of the vehicle(s) by Transit Plus, Inc. does not constitute acceptance by the agency. The vehicle will be considered "accepted" upon passing the inspection and issuance of an acceptance letter by the agency. The terms of this contract state that an agency has 10 calendar days after receiving vehicle(s) to perform the Post Delivery Inspection and issue either a "Letter of Acceptance" or a "Letter of Rejection" to Transit Plus, Inc. and their FDOT District Office. The "Letter of Rejection" will state and describe the areas to be found in noncompliance with the bid specifications and is incomplete or contains any defective or damaged parts. A vehicle should only be rejected if it fails to comply with the construction called for in the specifications or if does not have the equipment/options as ordered. Placing the vehicle(s) in revenue service will automatically constitute "acceptance"; however, a "Letter of Acceptance" should still be sent to Transit Plus, Inc.

Payment

Within five (5) days after accepting their vehicles(s), agencies should complete all necessary paperwork required by their FDOT District Office and submit their request for reimbursement along with the required documentation to their FDOT District Representative. At a minimum this will include:

- Three original signed FDOT invoices
- Letter of acceptance
- Proof of insurance
- Copy of title application listing FDOT as only lien holder
- Vin number
- Odometer reading

This should allow time to have Transit Plus, Inc. paid in full within sixty- (60)- days of acceptance. Agencies should note that failure to meet the net 60-day payment terms could result in the payment of interest and other penalties. Terms are those shown in the FVPP-03-SC-3 Bid Document. A 2% (24% per annum) service charge will be added to all past due accounts.

EXHIBIT A

SAMPLE ORDER FORM

SAMPLE ORDER FORM
FVPP-03-SC-3 (Small Cutaway Type Vehicles)
Transit Plus, Inc.

AGENCY NAME: _____ DATE: _____ P.O.: _____

CONTACT PERSON: _____ F.I.N.# _____

Feb 2006

Item	Cost	Quantity	Total Cost
Base Vehicle: Chevrolet 610/3500	\$44,967.00	1	\$44,967.00
Engine (Gasoline) Size: 6.0L Make: Cheyy Manufacturer: Chevrolet	Standard		
Engine (Diesel) Size: 6.6L Make: Duramax Manufacturer: Chevrolet	\$4,799.00		
Access Plate	\$0.00		
Stainless Steel Wheel Inserts	\$0.00		
Spare Tire/Wheel	\$0.00		
Seat Belt Extensions	\$12.00	1	\$12.00
Driver Seat A	\$445.00		
Driver Seat B	\$435.00		
Altro Flooring	\$814.00		
Public Address System	\$175.00		
AM/FM Radio	\$0.00	1	\$0.00
TOTAL PAGE ONE			\$44,979.00

SAMPLE ORDER FORM (cont)

Item	Cost	Quantity	Total Cost
Help Bumpers Front	\$667.00		
Help Bumper Rear	\$411.00	1	\$411.00
Side Wheel chair lift (Braun L919IB)	\$3,367.00		
Side Wheel chair lift (Ricon S-2005 and KlearView)	\$3,144.00	1	\$3,144.00
Side Wheel chair lift (Maxon WL-6A3353)	\$3,480.00		
Rear Wheel chair lift (Ricon KlearView)	\$3700.00		
Rear Wheel chair lift (Braun VL917IB)	\$3,700.00		
Sure-Lok restraint system (per position)	\$382.00	2	\$764.00
Q-Straint restraint system (per position)	\$476.00		
Sure-Lok SoLo restraint system (per position)	\$550.00		
Q-Straint Slide Lock restraint system (per position)	\$522.00		
Standard seat (per person)	\$179.00	2	\$358.00
Flip-Type seat (per person)	\$295.00	2	\$590.00
Fold-Away seat (per person)	\$378.00	8 (4 seats)	\$3,024.00
Child seat (per person)	\$145.00		
Paint scheme 1	\$448.00		
Paint scheme 2	\$448.00	1	\$448.00
Paint scheme 3	\$448.00		
TOTAL (total page 2)			\$8,291.00
TOTAL (total page 1)			\$44,979.00
GRAND TOTAL (total page 1 and page 2)			\$53,270.00

SAMPLE CHOICES FORM

SEATING AND FLOORING CHOICES

Seating Colors: (circle one) gray blue tan
Flooring Colors: (circle one) gray blue tan black
Paint Scheme: (circle one) #1 #2 #3

Agencies will select two (2) colors for the background and stripe when orders are placed. If an agency requires a paint and lettering scheme that is NOT GENERALLY covered by one of those listed, they may make separate arrangements with Transit Plus, Inc. to provide these services. Base price reflects white base coat.

WHEELCHAIR LIFT CHOICES

Wheel Chair Lift: (circle one) SIDE: Braun Maxon Ricon
REAR: Ricon Braun

SECUREMENT DEVICE CHOICES

W/C securement (circle one) STANDARD: Sure-Lok Q'Strait
LOW-PROFILE: Sure-Lok Q'Strait

PLANNED SERVICE REQUIREMENT

Planned Usage (circle one) Fixed Route Demand Response

TWO-WAY RADIO WIRING SETUP

Radio works with (circle one) Ignition On Only Ignition On or Off

EXHIBIT B

ORDER FORM

ORDER FORM
FVPP-03-SC-3 (Small Cutaway Type Vehicles)
Transit Plus, Inc.

AGENCY NAME: _____ DATE: _____ P.O.: _____

CONTACT PERSON: _____ F.I.N.# _____

Feb 2006

Item	Cost	Quantity	Total Cost
Base Vehicle: Chevrolet 610/3500	\$44,967.00		
Engine (Gasoline) Size: 6.0L Make: Cheyy Manufacturer: Cheyrolet	Standard		
Engine (Diesel) Size: 6.6L Make: Duramax Manufacturer: Chevrolet	\$4,799.00		
Access Plate	\$0.00		
Stainless Steel Wheel Inserts	\$0.00		
Spare Tire/Wheel	\$0.00		
Seat Belt Extensions	\$12.00		
Driver Seat A	\$445.00		
Driver Seat B	\$435.00		
Altro Flooring	\$814.00		
Public Address System	\$175.00		
AM/FM Radio	\$0.00		
TOTAL PAGE ONE			

ORDER FORM (cont)

Item	Cost	Quantity	Total Cost
Help Bumpers Front	\$667.00		
Help Bumper Rear	\$411.00		
Side Wheel chair lift (Braun L919IB)	\$3,367.00		
Side Wheel chair lift (Ricon S-2005 and KlearView)	\$3,144.00		
Side Wheel chair lift (Maxon WL-6A3353)	\$3,480.00		
Rear Wheel chair lift (Ricon KlearView)	\$3,700.00		
Rear Wheel chair lift (Braun VL917IB)	\$3,700.00		
Sure-Lok restraint system (per position)	\$382.00		
Q-Straint restraint system (per position)	\$476.00		
Sure-Lok SoLo restraint system (per position)	\$550.00		
Q-Straint Slide Lock restraint system (per position)	\$522.00		
Standard seat (per person)	\$179.00		
Flip-Type seat (per person)	\$295.00		
Fold-Away seat (per person)	\$378.00		
Child seat (per person)	\$145.00		
Paint scheme 1	\$448.00		
Paint scheme 2	\$448.00		
Paint scheme 3	\$448.00		
TOTAL (total page 2)			_____
TOTAL (total page 1)			_____
GRAND TOTAL (total page 1 and page 2)			_____

CHOICES FORM

SEATING AND FLOORING CHOICES

Seating Colors: (circle one) gray blue tan
Flooring Colors: (circle one) gray blue tan black
Paint Scheme: (circle one) #1 #2 #3

Agencies will select two (2) colors for the background and stripe when orders are placed. If an agency requires a paint and lettering scheme that is NOT GENERALLY covered by one of those listed, they may make separate arrangements with Transit Plus, Inc. to provide these services. Base price reflects white base coat.

WHEELCHAIR LIFT CHOICES

Wheel Chair Lift: (circle one) **SIDE:** Braun Maxon Ricon
REAR: Ricon Braun

SECUREMENT DEVICE CHOICES

W/C securement (circle one) **STANDARD:** Sure-Lok Q'Straint
LOW-PROFILE: Sure-Lok Q'Straint

PLANNED SERVICE REQUIREMENT

Planned Usage (circle one) Fixed Route Demand Response

TWO-WAY RADIO WIRING SETUP

Radio works with (circle one) Ignition On Only Ignition On or Off

EXHIBIT C

PAINT SCHEMES

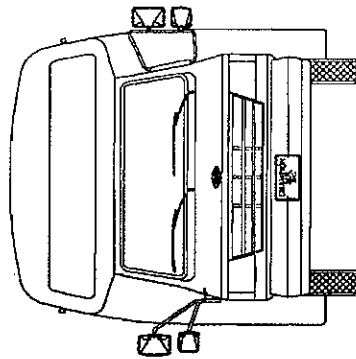
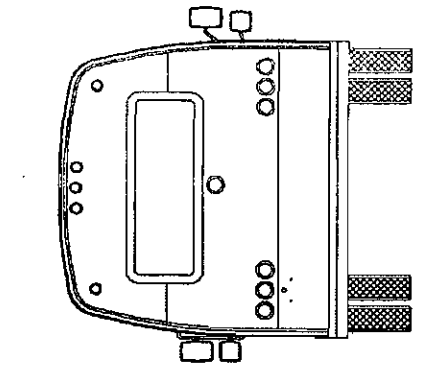

June 18, 2003

2" Stripe above the window
2 inches between top of B.O. A
(1" gap between top of B.O. A
bottom of stripes)
Full Black-Outlets (1" above &
1" below the windows)
2" Stripe
2" Gap
4" Stripe
2" Gap
2" Stripe

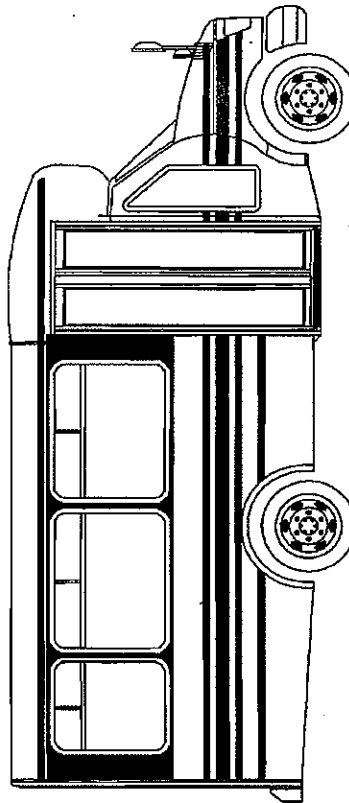
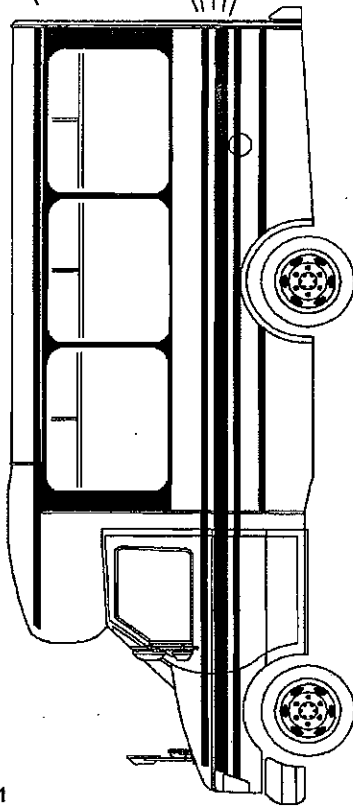

PAINT 1

Decal Location

A.) Approx. 7.25" Down from window

Skirt Colors (optional)

I

*Note: Full Blackouts 1" above &
below the windows. (Gloss-Black)

Vinyl Colors & Numbers

- 1.) Vinyl #007 (Silver Metallic) _____
- 2.) Vinyl #012 (Burgundy) _____
- 3.) Vinyl #007 (Silver Metallic) _____

File Name: "C:\DRIVE-1\ART1\CRAFT01.SCV"

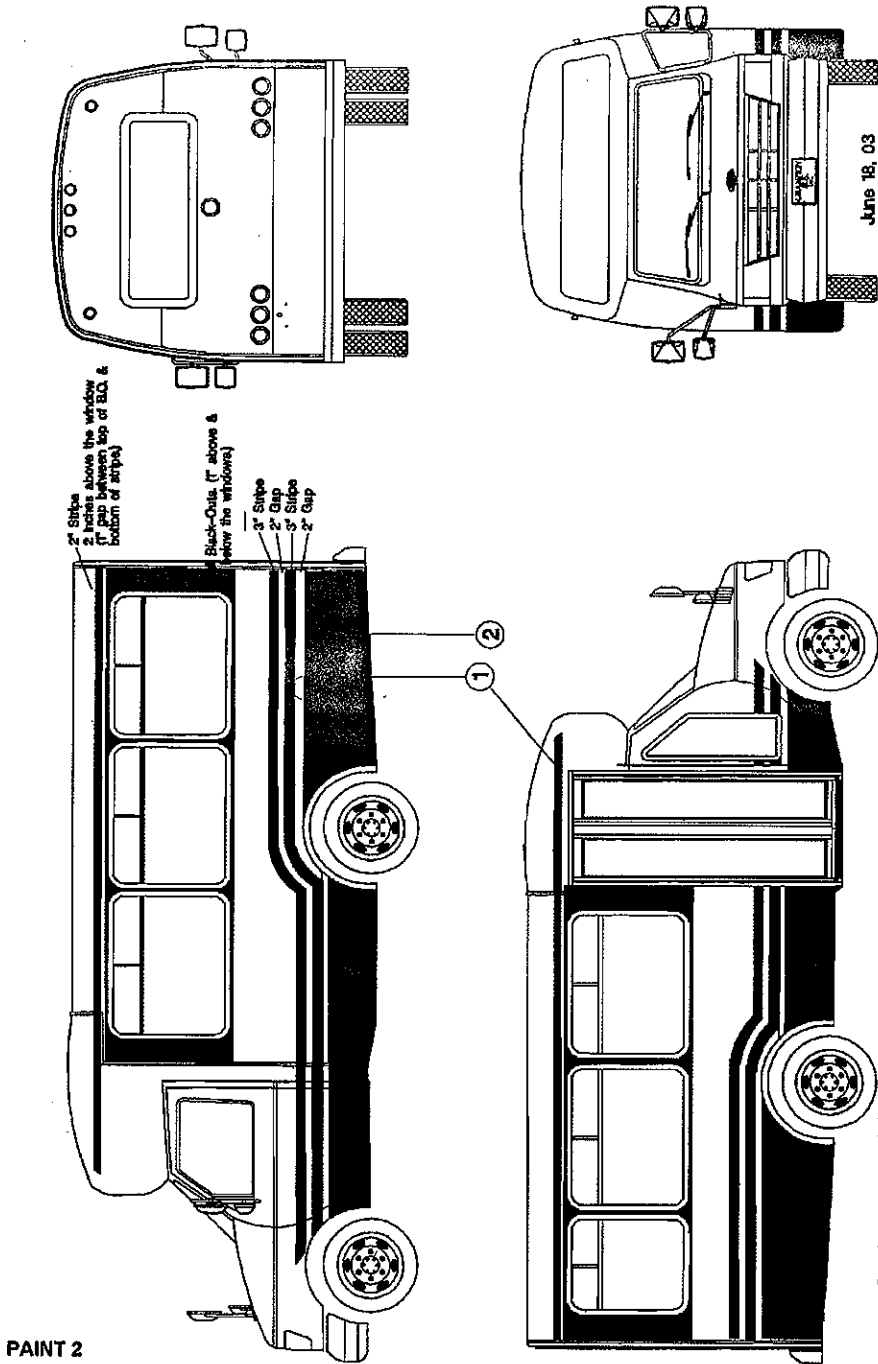

Paint Colors & Numbers

1.) PPG #TBD (Blue)

2.) PPG #TBD (Silver)

1 Paint #TBD (Silver)

*Note: Full Blackouts 1" above & below the windows. (Gloss-Black)

Decal Location

A.) Approx. 725" Down from window

June 18, 03

File Name: "C:\DDRIVE-1\ARTI\CRFDOT2.SCV"

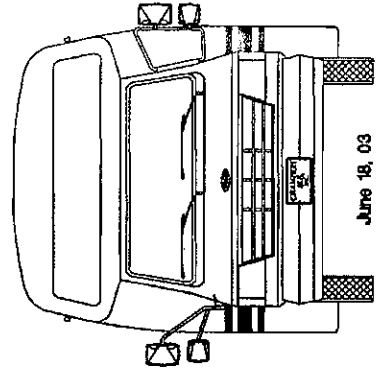
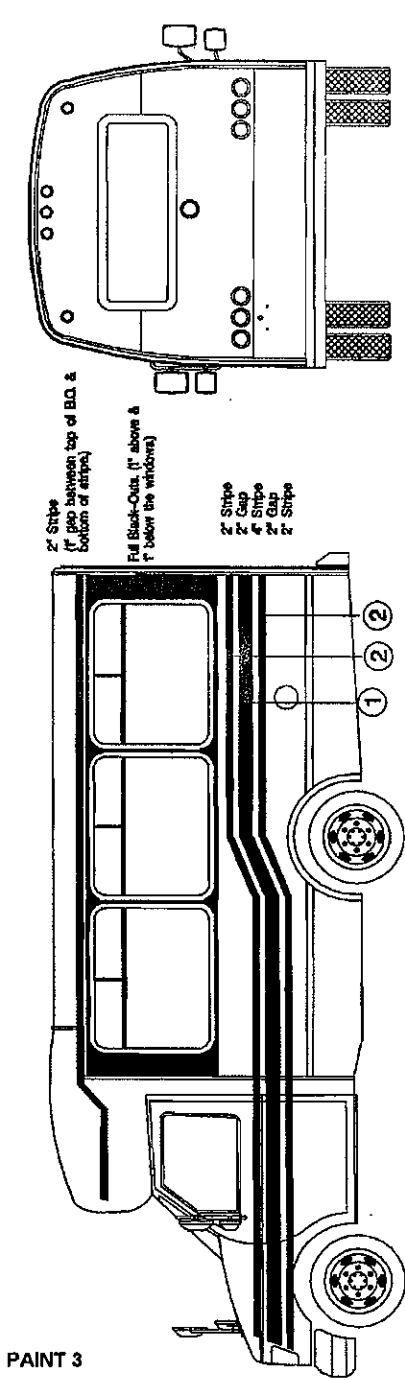

Decal Location

A.) Approx. 400" Down from window

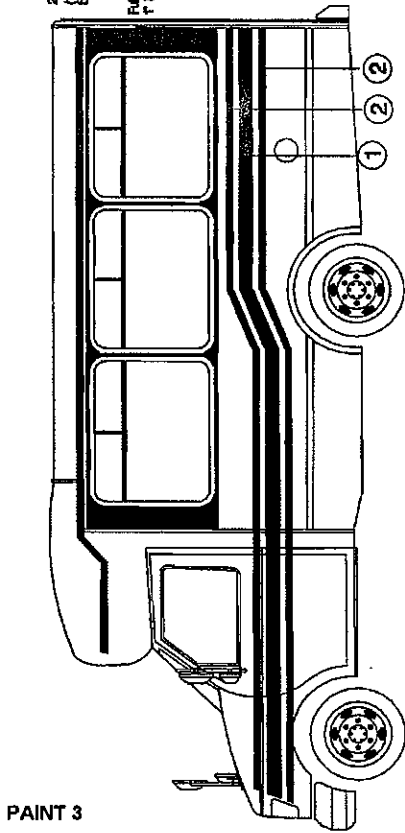

Skirt Colors (optional)

*Note: Full Blackouts 1" above & below the windows. (Gloss-Black)

Vinyl Colors & Numbers

- 1.) Vinyl #TBD (Green)
- 2.) Vinyl #TBD (Silver)

File Name: "C:\DDRIVE-1\SALES\F-DOT-3.SCV"

EXHIBIT D

OPTIONS

2.2.0 ENGINE

2.2.2 No gasoline power plant option.

2.2.3 No diesel power plant option.

2.4.0 ACCESS PLATE

2.4.5 An access plate made of slip resistant 11ga. aluminum diamond plate shall be installed in the interior floor to allow access to the fuel sending unit.

2.13.0 TIRES AND WHEELS

2.13.2 Stainless steel wheel inserts added to steel wheels.

2.13.3 A mounted and balanced spare tire and wheel assembly shipped loose with each vehicle.

2.26.0 SEAT BELT EXTENSIONS

2.26.7 Provided in sets of two (2).

2.28.0 DRIVER SEAT

2.28.2 Freedman Magnum 200. Seat shall be fully adjustable type and shall include shoulder and lap restraining belt with retractor, right armrest, and lumbar support. The upholstery shall be color keyed to the passenger seats.

2.28.3 Freedman Relaxor Sport Seat.

2.29.0 ALTRO-FLOORING

2.29.1 Altro Transflor slip resistant sheet vinyl flooring.

2.33.0 PUBLIC ADDRESS SYSTEM/AM-FM RADIO

2.33.2 Radio Engineering Industries (REI) driver controlled public address system.

2.33.3 OEM standard AM/FM radio mounted in dash.

2.40.0 HELP BUMPERS – FRONT AND REAR

2.40.2 HELP® Intermediate Bumpers shall be optional on front or rear of the vehicle, to give an extra measure of protection against low-speed impact collisions of 5-MPH or less.

2.43.0 WHEELCHAIR LIFTS

2.43.3 Side mounted wheel chair lift (per part 2, Braun or Ricon or Maxon)

2.43.3 Rear mounted wheel chair lift (per part 2, Ricon or Braun)

2.44.0 RESTRAINT SYSTEMS

2.44.3 Sure-Lok or Q'Straint restraint system (per part 2)

2.44.3 Sure-Lok or Q'Straint Low Profile restraint system (per part

EXHIBIT E

SAMPLE

FLOOR-PLAN LAYOUTS

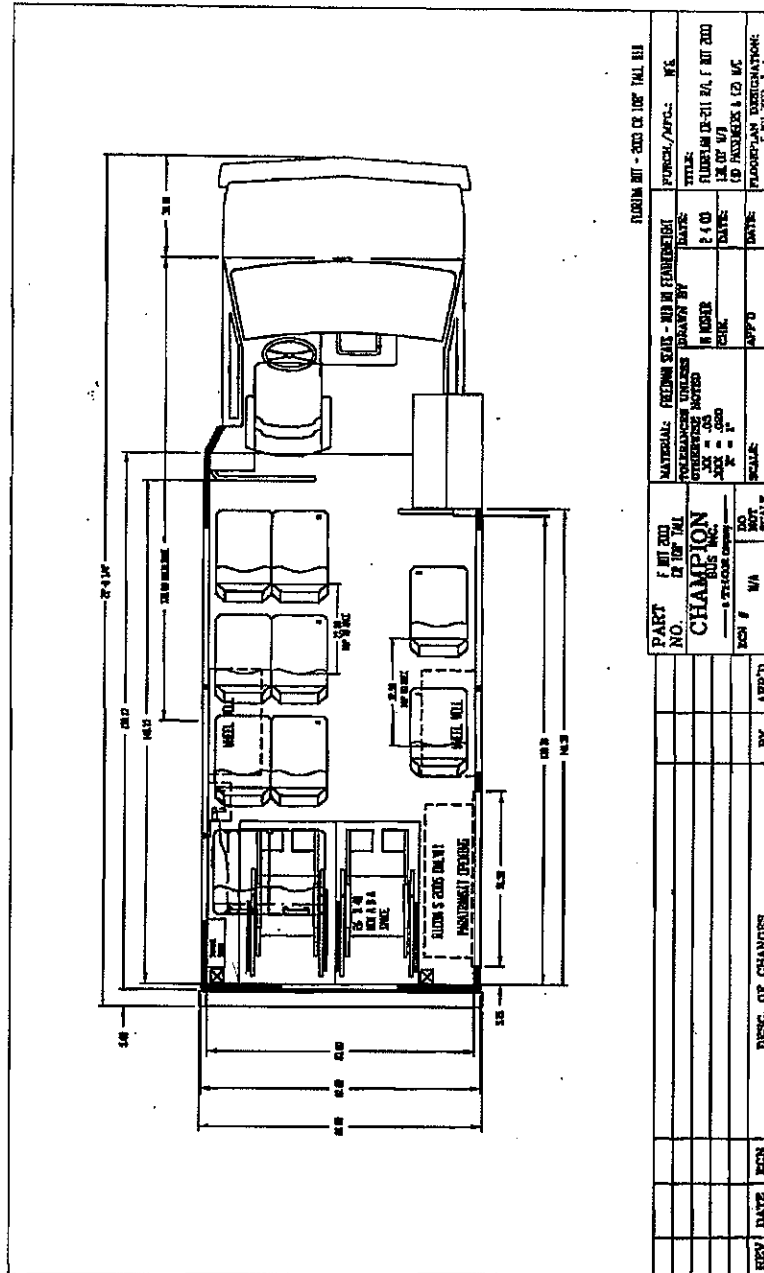

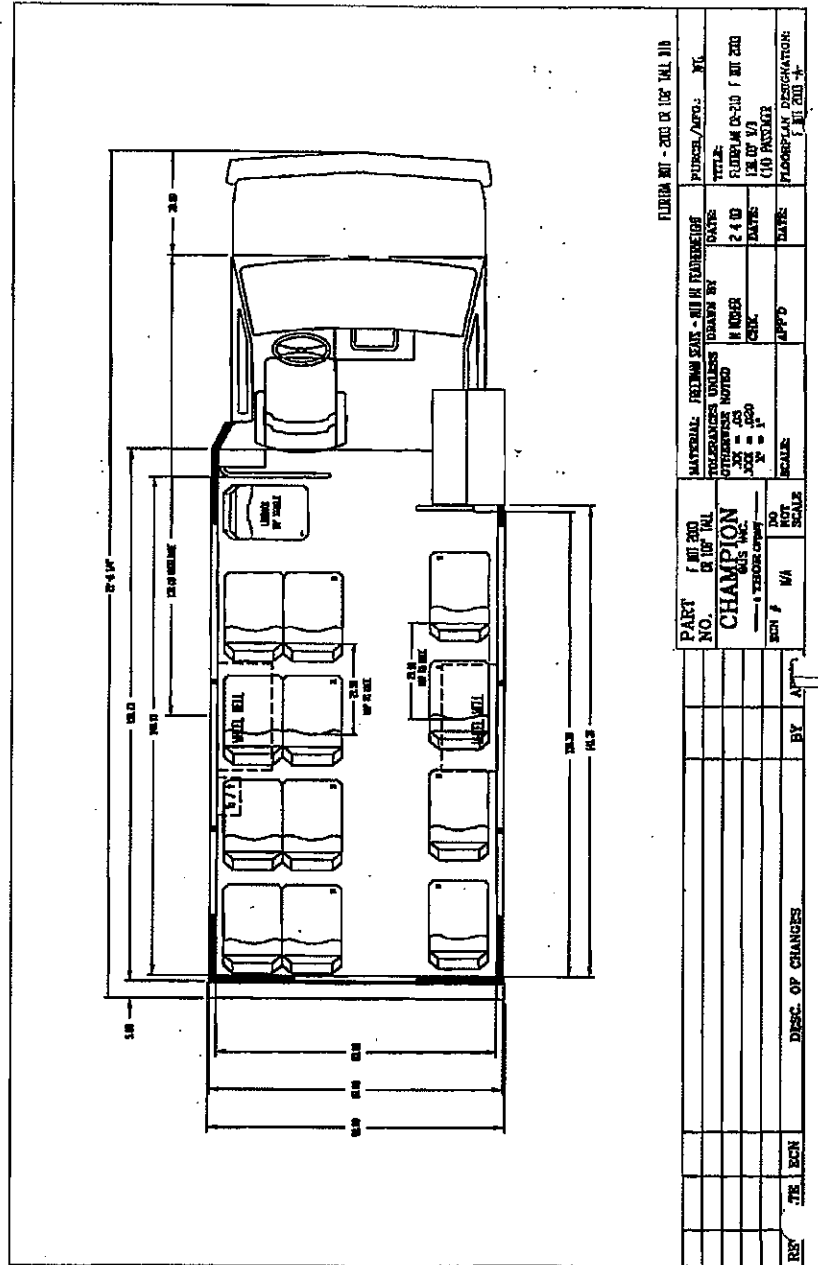

PART NO. OF THE DRAWING		MATERIAL: PRELIM SEAT - 80 IN FRAME/HEIGHT		PURCHASE/APP'D. DATE	
CHAMPION BUS INC.		DRAWN BY		DATE	
REV. 1		M. ROSS		2.4.00	
REV. 2		CENIC		DATE	
REV. 3		APP'D.		DATE	
REV. 4		SCALE		DATE	
REV. 5		SCALE		DATE	
REV. 6		SCALE		DATE	
REV. 7		SCALE		DATE	
REV. 8		SCALE		DATE	
REV. 9		SCALE		DATE	
REV. 10		SCALE		DATE	
REV. 11		SCALE		DATE	
REV. 12		SCALE		DATE	
REV. 13		SCALE		DATE	
REV. 14		SCALE		DATE	
REV. 15		SCALE		DATE	
REV. 16		SCALE		DATE	
REV. 17		SCALE		DATE	
REV. 18		SCALE		DATE	
REV. 19		SCALE		DATE	
REV. 20		SCALE		DATE	
REV. 21		SCALE		DATE	
REV. 22		SCALE		DATE	
REV. 23		SCALE		DATE	
REV. 24		SCALE		DATE	
REV. 25		SCALE		DATE	
REV. 26		SCALE		DATE	
REV. 27		SCALE		DATE	
REV. 28		SCALE		DATE	
REV. 29		SCALE		DATE	
REV. 30		SCALE		DATE	
REV. 31		SCALE		DATE	
REV. 32		SCALE		DATE	
REV. 33		SCALE		DATE	
REV. 34		SCALE		DATE	
REV. 35		SCALE		DATE	
REV. 36		SCALE		DATE	
REV. 37		SCALE		DATE	
REV. 38		SCALE		DATE	
REV. 39		SCALE		DATE	
REV. 40		SCALE		DATE	
REV. 41		SCALE		DATE	
REV. 42		SCALE		DATE	
REV. 43		SCALE		DATE	
REV. 44		SCALE		DATE	
REV. 45		SCALE		DATE	
REV. 46		SCALE		DATE	
REV. 47		SCALE		DATE	
REV. 48		SCALE		DATE	
REV. 49		SCALE		DATE	
REV. 50		SCALE		DATE	
REV. 51		SCALE		DATE	
REV. 52		SCALE		DATE	
REV. 53		SCALE		DATE	
REV. 54		SCALE		DATE	
REV. 55		SCALE		DATE	
REV. 56		SCALE		DATE	
REV. 57		SCALE		DATE	
REV. 58		SCALE		DATE	
REV. 59		SCALE		DATE	
REV. 60		SCALE		DATE	
REV. 61		SCALE		DATE	
REV. 62		SCALE		DATE	
REV. 63		SCALE		DATE	
REV. 64		SCALE		DATE	
REV. 65		SCALE		DATE	
REV. 66		SCALE		DATE	
REV. 67		SCALE		DATE	
REV. 68		SCALE		DATE	
REV. 69		SCALE		DATE	
REV. 70		SCALE		DATE	
REV. 71		SCALE		DATE	
REV. 72		SCALE		DATE	
REV. 73		SCALE		DATE	
REV. 74		SCALE		DATE	
REV. 75		SCALE		DATE	
REV. 76		SCALE		DATE	
REV. 77		SCALE		DATE	
REV. 78		SCALE		DATE	
REV. 79		SCALE		DATE	
REV. 80		SCALE		DATE	
REV. 81		SCALE		DATE	
REV. 82		SCALE		DATE	
REV. 83		SCALE		DATE	
REV. 84		SCALE		DATE	
REV. 85		SCALE		DATE	
REV. 86		SCALE		DATE	
REV. 87		SCALE		DATE	
REV. 88		SCALE		DATE	
REV. 89		SCALE		DATE	
REV. 90		SCALE		DATE	
REV. 91		SCALE		DATE	
REV. 92		SCALE		DATE	
REV. 93		SCALE		DATE	
REV. 94		SCALE		DATE	
REV. 95		SCALE		DATE	
REV. 96		SCALE		DATE	
REV. 97		SCALE		DATE	
REV. 98		SCALE		DATE	
REV. 99		SCALE		DATE	
REV. 100		SCALE		DATE	

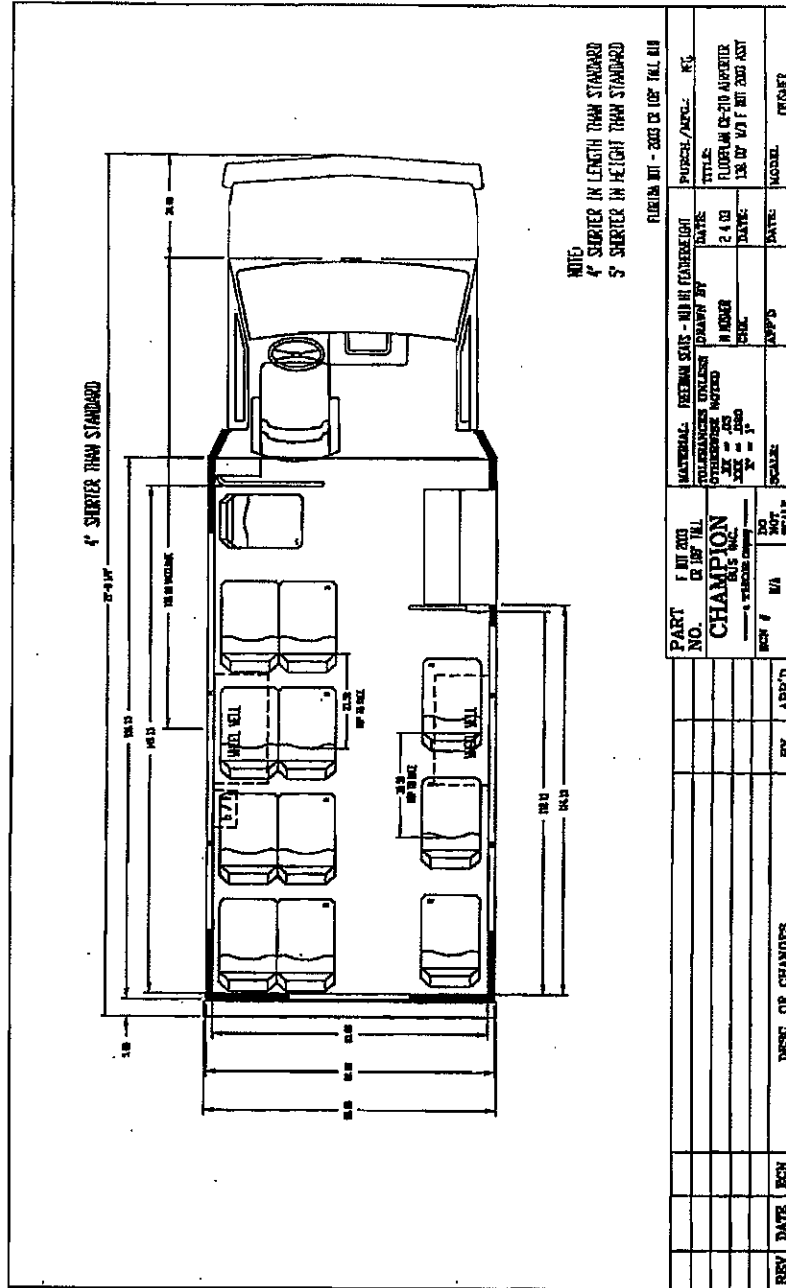

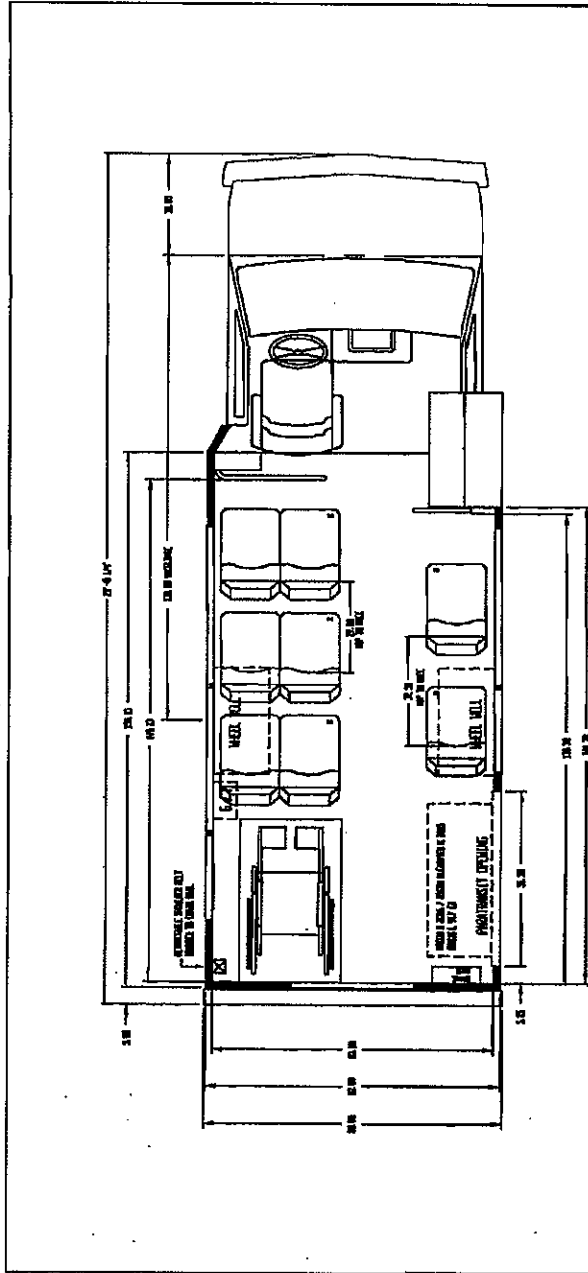

REV		ECH	DISC. OF CHANGES	BY	APP'D	DATE
PART NO.		F 001 300				
TITLE		MATERIALS FREEMAN 5015 - 113 H. HANSEN		DATE		
DESIGNED BY		T. HANSEN		DATE		
CHECKED BY		B. HANSEN		DATE		
SCALE		AS SHOWN		DATE		
DO NOT SCALE		SCALE		DATE		
PART NO.		CHAMPION				
TITLE		MATERIALS FREEMAN 5015 - 113 H. HANSEN		DATE		
DESIGNED BY		T. HANSEN		DATE		
CHECKED BY		B. HANSEN		DATE		
SCALE		AS SHOWN		DATE		
DO NOT SCALE		SCALE		DATE		
PROJECT NO.		F 001 300				
TITLE		MATERIALS FREEMAN 5015 - 113 H. HANSEN		DATE		
DESIGNED BY		T. HANSEN		DATE		
CHECKED BY		B. HANSEN		DATE		
SCALE		AS SHOWN		DATE		
DO NOT SCALE		SCALE		DATE		
PROJECT NO.		F 001 300				

FROM 2 COPY OF FORD/CALTRANS BY DATE 1/23/03

REV#	DATE	BY	DESC. OF CHANGES

PART NO.	QTY	UNIT	DESCRIPTION	BY	DATE	SCALE	DO NOT SCALE

FLORIDA DOT - BID EX. REF. TALL BID

MATERIALS	ISSUED	DATE	BY	DATE	BY	DATE	BY	DATE	BY	DATE	BY

PROJECT	NO.	DESCRIPTION	DATE	BY	SCALE	DO NOT SCALE

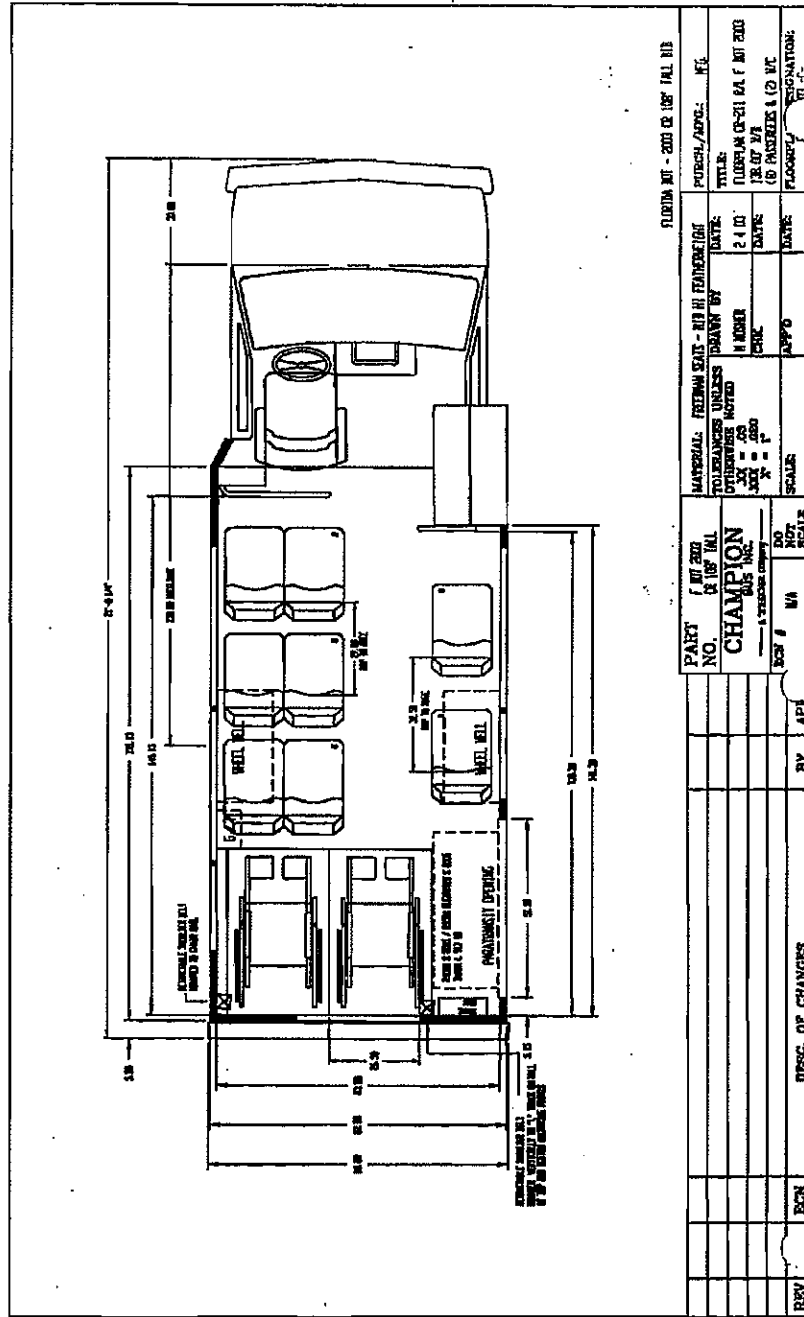

REV	DESCRIPTION	DATE	BY	APP	SCALE	DATE	BY	APP	SCALE

EXHIBIT F

WARRANTY PROVISIONS

WARRANTY PROVISIONS

5.0.0 BASIC PROVISIONS

5.1.0 WARRANTY REQUIREMENTS

Warranties in this document are in addition to any statutory remedies or warranties imposed on Transit Plus, Inc. Consistent with this requirement Transit Plus, Inc. warrants and guarantees to the FVPP each complete vehicle, and specific subsystems and components as follows:

5.1.1 COMPLETE VEHICLE

The vehicle is warranted and guaranteed to be free from defects for a minimum of twenty-four (24) months or twenty-four thousand (24,000) miles, whichever comes first, beginning on the date of acceptance of each vehicle. During this warranty period, the vehicle shall maintain its structural and functional integrity. The warranty is based on regular operation of the vehicle under the operating conditions prevailing in the FVPP's locale.

5.1.2 SUBSYSTEMS AND COMPONENTS

Specific subsystems and components are warranted and guaranteed to be free from defects and related defects for the times and/or mileages given in exhibit 5-1. Parts and Labor to be covered in all warranties.

Exhibit 5-1.

Subsystem and component minimum warranty, whichever occurs first.

Item	Years	Mileage
OEM Chassis	3	36,000
Manufacturers Warranty	2	24,000
Air conditioning system (Owner selects which one)	3/5	Unlmted/75,000
Alternator (OEM duals are 3/36,000)	18 months	75,000
Wheelchair Lift	3 (parts & labor)	Unlimited

5.2.0 VOIDING OF WARRANTY

The warranty shall not apply to any part or component of the vehicle that has been subject to misuse negligence, accident, or that has been repaired or altered in any way so as to affect adversely its performance or reliability, except insofar as such repairs were in accordance with Transit Plus, Inc.'s maintenance manuals and the workmanship was in accordance with recognized standards of the industry. The warranty shall also be void if the FVPP fails to conduct normal inspections and scheduled preventive maintenance procedures as recommended in Transit Plus, Inc.'s maintenance manuals.

5.3.0 EXCEPTIONS TO WARRANTY

The warranty shall not apply to scheduled maintenance items, and items such as tires and tubes, nor to items furnished by the FVPP such as radios, fare boxes, and other auxiliary equipment, except insofar as such equipment may be damaged by the failure of a part or component for which Transit Plus, Inc. is responsible.

5.4.0 DETECTION OF DEFECTS

If the purchaser detects a defect within the warranty periods defined in section 5.1.1, it shall promptly notify Transit Plus, Inc.'s representative. Within five (5) working days after receipt of notification, Transit Plus, Inc.'s representative shall either agree that the defect is in fact covered by the "complete vehicle" warranty, or reserve judgment until the subsystem or component is inspected by Transit Plus, Inc.'s representative and/or is removed and examined at the purchaser 's property or at Transit Plus, Inc.'s plant. At that time, the status of warranty coverage, either subsystem or vehicle, shall be mutually resolved between the purchaser and Transit Plus, Inc. If the defect belongs to a subsystem or component, then work necessary to effect the repairs defined in section 5.1.2 shall commence within ten (10) working days after receipt of notification by Transit Plus, Inc. Otherwise, section 5.1.1 applies and repairs will be started immediately.

5.5.0 SCOPE OF WARRANTY REPAIRS

When warranty repairs are required, the FVPP and Transit Plus, Inc.'s representative shall agree within five (5) days after notification on the most appropriate course for the repairs and the exact scope of the repairs to be performed under the warranty. If no agreement is obtained within the five (5) day period, the FVPP reserves the right to commence the repairs in accordance with 5.7.1.

5.6.0 FLEET DEFECTS

A fleet defect is defined as the failure of identical items covered by the warranty and occurring in the warranty period in a proportion of the vehicles delivered under this contract. For the purpose of this bid, identical defects occurring in sixty (60) percent of vehicles delivered shall be considered a "fleet defect".

5.6.1 SCOPE OF WARRANTY PROVISIONS

Transit Plus, Inc. shall correct a fleet defect under the warranty provisions defined in section 5.4.0. After correcting the defect, Transit Plus, Inc. shall promptly undertake and complete a work program reasonably designed to prevent the occurrence of the same defect in all other vehicles purchased under this contract. The work program shall include inspection and/or correction of the potential or defective parts in all of the vehicles. The warranty on items determined to be fleet defects shall be extended for the time and/or miles of the original warranty. This extended warranty shall begin on the date a fleet defect was determined to exist, or on the repair/replacement date for corrected items.

5.6.2 VOIDING OF WARRANTY PROVISIONS

The fleet defect provisions shall not apply to vehicle defects caused by noncompliance with Transit Plus, Inc.'s recommended normal maintenance practices and procedures.

5.6.3 EXCEPTIONS TO WARRANTY PROVISIONS

Fleet defect warranty provisions shall not apply to damage that is a result of normal wear and tear in service to such items as seats, floor covering, windows, interior trim, and paint. The provisions shall not apply to purchaser-supplied items such as fare boxes, radios, and tires.

5.7.0 REPAIR PROCEDURES

5.7.1 REPAIR PERFORMANCE

In some instances, the FVPP may require Transit Plus, Inc. or its designated representative to perform warranty-covered repairs that are clearly beyond the scope of its capabilities. In these cases, this work will be done by the FVPP's personnel with reimbursement by Transit Plus, Inc.

5.7.2 REPAIRS BY CONTRACTOR

If the FVPP requires Transit Plus, Inc. to perform warranty-covered repairs, Transit Plus, Inc.'s representative must begin within ten (10) working days after receiving notification of a defect from the purchaser, work necessary to effect repairs. The purchaser shall make the vehicle available to complete repairs timely with Transit Plus, Inc. repair schedule. Transit Plus, Inc. shall provide at its own expense all spare parts, tools, and space required to complete repairs. At the FVPP's option, Transit Plus, Inc. may be required to remove the vehicle from the purchaser's property while repairs are being effected. If the vehicle is removed from the purchaser's property, repair procedures must be diligently pursued by Transit Plus, Inc.'s representative.

5.8.0 REPAIRS BY THE PURCHASER

5.8.1 PARTS USED

If the purchaser performs the warranty-covered repairs, it shall correct or repair the defect and any related defects using contractor-specified spare parts available from its own stock or those supplied by Transit Plus, Inc. specifically for this repair. Monthly, or at a period to be mutually agreed upon, reports of all repairs covered by this warranty shall be submitted by the purchaser to Transit Plus, Inc. for reimbursement or replacement of parts. Transit Plus, Inc. shall provide forms for these reports.

5.8.2 CONTRACTOR SUPPLIED PARTS

The FVPP may request that Transit Plus, Inc. supply new parts for warranty-covered repairs being performed by the purchaser. These parts shall be shipped prepaid to the purchaser, from any source selected by Transit Plus, Inc., the "next business day" from receipt of the request for said parts.

5.8.3 DEFECTIVE COMPONENTS RETURN

Transit Plus, Inc. may request that parts covered by the warranty be returned to the manufacturing plant. The total cost for this action shall be paid by Transit Plus, Inc. Materials should be returned in accordance with contractor's instructions.

5.8.4 REIMBURSEMENT FOR LABOR

The purchaser shall be reimbursed by Transit Plus, Inc. for labor. The amount shall be determined by multiplying the number of man-hours actually required to correct the defect by the purchaser's current per hour, master mechanic, straight wage rate, plus 32 percent fringe benefits, plus the cost of towing in the vehicle if such action was necessary and if the vehicle was in the normal service area. These wage and fringe benefit rates shall not exceed the rates in effect in the purchaser's service garage at the time the defect correction is

made. The purchaser shall not accept parts credit as payment of warranty labor claims.

5.8.5 REIMBURSEMENT FOR PARTS

The purchaser shall be reimbursed by Transit Plus, Inc. for defective parts and for parts that must be replaced to correct the defect. The reimbursement shall be at the invoice cost of the part(s) at the time of repair and shall include taxes where applicable and 2 percent handling charges. The purchaser shall not accept parts credit as payment of warranty part claims.

5.9.0 WARRANTY AFTER REPLACEMENT / REPAIRS

If any component, unit, or subsystem is repaired, rebuilt, or replaced by Transit Plus, Inc. or by the FVPP's personnel, with the concurrence of Transit Plus, Inc., the subsystem shall have the unexpired warranty period of the original subsystem.

FVPP PROPOSAL # FVPP-03-SC-3

PRE-AWARD REVIEW CERTIFICATIONS

Edward Bart, acting on behalf of agencies purchasing vehicles under the contract established by FVPP Proposal # FVPP-03-SC, certifies the following:

I. PRE-AWARD BUY AMERICA COMPLIANCE CERTIFICATION

As required by Title 49 of the CFR, Part 663 - Subpart B, the recipient is satisfied that the buses to be purchased from Transit Plus, Inc. meet the requirements of Section 165(b)(3) of the Surface Transportation Assistance Act of 1982, as amended. The recipient has reviewed documentation provided by the manufacturer, which lists (1) the proposed component and subcomponent parts of the buses identified by manufacturer, country of origin, and cost; and (2) the proposed location of the final assembly point for the buses, including a description of the activities that will take place at the final assembly point and cost of final assembly.

Date: June 10, 2003

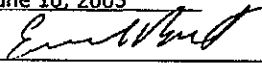
Signature:  Title: Program Administrator

II. PRE-AWARD PURCHASER'S REQUIREMENTS CERTIFICATION

As required by Title 49 of the CFR, Part 663 - Subpart B, the buses to be purchased from Transit Plus, Inc. are the same product described in the recipient's solicitation specification and that the proposed manufacturer is a responsible manufacturer with the capability to produce a bus that meets the specifications.

Date: June 10, 2003

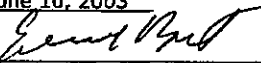
Signature:  Title: Program Administrator

III. PRE-AWARD FMVSS COMPLIANCE CERTIFICATION

As required by Title 49, of the CFR, Part 663 - Subpart D, a copy of Transit Plus, Inc. self-certification information stating that the buses will comply with the relevant Federal Motor Vehicle Safety Standards issued by the National Highway Traffic Safety Administration in Title 49 of the Code of Federal Regulations, Part 571.

Date: June 10, 2003

Signature:  Title: Program Administrator

STANDARD ASSURANCES

Federal Requirements for Invitation for Proposal

I, David Morris, representing the Proposer, certify that I have read and understand all terms and conditions of the Federal Requirements for Invitation for Proposal and, if awarded this proposal, will comply with all terms and conditions contained therein.

Comptroller General's Proposer's Certification

Transit Plus, Inc. hereby certifies that they are NOT on the Comptroller General's list of Ineligible Contractors. Manufacturers appearing on said list will be considered ineligible.

Other Assurances

I, David Morris, representing the Proposer, assure that the Proposer is licensed to sell vehicles in the State of Florida, under license # Y1 21451.

Transit Plus, Inc. assures that equipment proposal will meet or exceed all specifications, and that all equipment and items specified in the vehicle specifications arrive with the vehicle at time of delivery to the Purchaser.

Transit Plus, Inc. assures that local representation of the manufacturer has been secured and will be liable for warranty work on the vehicle(s).

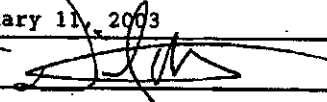
DATE February 11, 2003
SIGNATURE 
COMPANY NAME Transit Plus, Inc.
TITLE Fleet Contracts Mgr.

DEPARTMENT OF HIGHWAY SAFETY AND MOTOR VEHICLES
DIVISION OF MOTOR VEHICLES

LICENSE YEAR	LICENSE NUMBER
2001 - 2002	VI 21451

License

TRANSIT PLUS INC
58 WEST 9TH STREET
ATLANTIC BCH FL 32233 - 0000

TRANSIT PLUS INC
58 WEST 9TH STREET
ATLANTIC BCH FL 32233 - 0000

**CERTIFICATION REQUIREMENT FOR PROCUREMENT OF STEEL, IRON, OR
MANUFACTURED PRODUCTS**

Certificate of Compliance with 49 U.S.C. 5323(j)(1)

The proposer or Offeror hereby certifies that it will meet the requirements of 49 U.S.C. 5323(j)(1) and the applicable regulations in 49 CFR Part 661.

Date February 10, 2003

Signature 

Company Name Transit Plus, Inc.

Title Fleet Contracts Mgr.

Certificate of Non-Compliance with 49 U.S.C. 5323(j)(1)

The proposer or Offeror hereby certifies that it cannot comply with the requirements of 49 U.S.C. 5323(j)(1), but it may qualify for an exception pursuant to 49 U.S.C. 5323(j)(2)(B) or (j)(2)(D) and the regulations in 49 CFR 661.7.

Date _____

Signature _____

Company Name _____

Title _____

**CERTIFICATION REQUIREMENT FOR PROCUREMENT OF BUSES, OTHER ROLLING
STOCK AND ASSOCIATED EQUIPMENT**
(Applicable to purchases over \$100,000.00)

Certificate of Compliance with 49 U.S.C. 5323(j)(2)(C).

The proposer or Offeror hereby certifies that it will comply with the requirements of 49 U.S.C. 5323(j)(2)(C) and the regulations at 49 CFR Part 661.

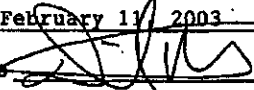
Date February 11, 2003
Signature 
Company Name Transit Plus, Inc.
Title Fleet Contracts Mgr.

Certificate of Non-Compliance with 49 U.S.C. 5323(j)(2)(C)

The proposer or Offeror hereby certifies that it cannot comply with the requirements of 49 U.S.C. 5323(j)(2)(C), but may qualify for an exception pursuant to 49 U.S.C. 5323(j)(2)(B) or (j)(2)(D) and the regulations in 49 CFR 661.7.

Date _____
Signature _____
Company Name _____
Title _____

**BUY AMERICA CERTIFICATE OF COMPLIANCE WITH FTA
REQUIREMENTS FOR BUSES, OTHER ROLLING STOCK, OR ASSOCIATED
EQUIPMENT**

*(To be submitted with a proposal or offer exceeding the small purchase threshold for
Federal assistance programs, currently set at \$100,000.)*

Certificate of Compliance

The proposer hereby certifies that it will comply with the requirements of 49 U.S.C. Section 5323(j)(2)(C), Section 165(b)(3) of the Surface Transportation Assistance Act of 1982, as amended, and the regulations of 49 C.F.R. 661.11:

Date: February 11, 2003

Signature: 

Company Name: Transit Plus, Inc.

Title: Fleet Contracts Mgr.



CHAMPION
BUS INC.
— a **THOR** company —

331 Graham Road
P.O. Box 158
Imlay City, MI 48444
(810) 724-6474

Fax Eng. (810) 724-7748
Fax Purch. (810) 724-7661
Fax Sales (810) 724-1844

PRE-DELIVERY BUY AMERICA
(Domestic Content Worksheet)

STATE OF FLORIDA

**AT LEAST OF 60% OF THE TOTAL COST OF THE STATE OF FLORIDA BUS IS
U.S. DOMESTIC CONTENT:**

Component / Manufacturer	Final Assembly	Domestic Content
Chassis/Ford	U.S.	56% of Total Cost
Air Cond/Trans Air	U.S.	3% of Total Cost
Seats/Freedman	U.S.	3% of Total Cost
Steel Structure	U.S.	1% of Total Cost
Windows/Passenger	U.S.	.5% of Total Cost
Flooring	U.S.	.5% of Total Cost
Tubing/ Stanchions	U.S.	1% of Total Cost
		TOTAL: 65% of Total Cost

**FINAL ASSEMBLY WILL BE AT IMLAY CITY, MICHIGAN, USA. THE COST OF
THE FINAL ASSEMBLY WILL BE 10% OF THE TOTAL COST. THE FOLLOWING
ACTIVITIES WILL TAKE PLACE AT THE FINAL ASSEMBLY POINT:**

- *Construct Body (Roof, Sidewalls, Windows, and Floors).**
- *Mount Body To Chassis**
- *Install Customer Specified Options, Such as Wheelchair Lifts, Seats, Flooring, Etc.**
- *Fabricate And Install Wiring Harnesses**
- *Exterior And Interior Paint And Lettering**

Rick Lee
R. Lee
12/5/01

CERTIFICATION OF COMPLIANCE WITH FTA'S BUS TESTING REQUIREMENTS

The undersigned [Contractor/Manufacturer] certifies that the vehicle offered in this procurement complies with 49 U.S.C. A 5323© and FTA's implementing regulation at 49 CFR Part 665.

The undersigned understands that misrepresenting the testing status of a vehicle acquired with Federal financial assistance may subject the undersigned to civil penalties as outlined in the Department of Transportation's regulation on Program Fraud Civil Remedies, 49 CFR Part 31. In addition, the undersigned understands that FTA may suspend or debar a manufacturer under the procedures in 49 CFR Part 29.

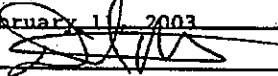
Date: February 1, 2003
Signature: 
Company Name: Transit Plus, Inc.
Title: Fleet Contracts Mgr.

STURAA TEST

4 YEAR

100,000 MILE BUS

from

CHAMPION MOTOR COACH, INC.

CHALLENGER MODEL CH-241

NOVEMBER 1992

PTI-BT-R9214

PENNSTATE



The Pennsylvania Transportation Institute

201 Research Office Building
The Pennsylvania State University
University Park, PA 16802

(814) 865-1891

Bus Testing and Research Center

6th Avenue and 45th Street
Altoona, PA 16602

(814) 949-7944



U.S. Department
of Transportation
Federal Transit
Administration

Headquarters

400 Seventh St., S.W.
Washington, D.C. 20591

Mr. Thomas J. Ensich
President
Champion Motor Coach Inc.
P.O. Box 158
331 Graham Road
Inlay City, Michigan 48444

FEB 10 1994

Dear Mr. Ensich:

This is in response to your recent correspondence in which you requested that the Federal Transit Administration (FTA) confirm your interpretation of the bus testing regulation (49 CFR Part 665, 58 Fed. Reg. 58732, November 3, 1993) as it applies to your Crusader (CR Series) buses.

FTA notes that a Champion model CH-241 bus has previously undergone full testing at the Pennsylvania Transportation Institute Bus Testing Facilities (PTI). Consequently, all unmodified mass-produced vehicles manufactured from a Ford E-350 chassis are eligible for partial testing procedures. FTA further notes that the CR Series vehicles are 12-inches narrower than the CH-241 model.

As indicated in the FTA "Testing Requirement Guidelines for 4- and 5-Year Vehicles" (public availability announced in 49 CFR Part 665, 58 Fed. Reg. 30213, May 26, 1993), a change in width of more than 4-inches between the family member that was tested at PTI and a proposed family member, may require additional testing because significantly different test results might be expected. However, after analysis of vehicle parameters such as the ratio of lateral center of gravity to rear wheel tread width, induced roll inertia, and the ratio of longitudinal center of gravity to wheelbase, FTA determines that there would not be a significant change in data previously obtained, therefore, the Champion CR Series of vehicles are not required to undergo additional testing and are considered part of the "family of vehicles" established by the CH-241 PTI test.

Please feel free to call me at (202) 366-0090 or Bart W. Mancini of my staff at (202) 366-8063, if you require additional assistance.

Sincerely,

A. M. Tony Yen
Deputy Associate Administrator for
Technical Assistance, and
Acting Director,
Office of Engineering

CERTIFICATION REGARDING LOBBYING

To be submitted with each proposal or offer exceeding \$100,000

The undersigned [Contractor] certifies, to the best of his or her knowledge and belief, that:

1. No Federal appropriated funds have been paid or will be paid, by or on behalf of the undersigned, to any person for influencing or attempting to influence an officer or employee of an agency, a Member of Congress, an officer or employee of Congress, or an employee of a Member of Congress in connection with the awarding of any Federal contract, the making of any Federal grant, the making of any Federal loan, the entering into of any cooperative agreement, and the extension, continuation, renewal, amendment, or modification of any Federal contract, grant, loan, or cooperative agreement.

2. If any funds other than Federal appropriated funds have been paid or will be paid to any person for making lobbying contacts to an officer or employee of any agency, a Member of Congress, an officer or employee of Congress, or an employee of a Member of Congress in connection with this Federal contract, grant, loan, or cooperative agreement, the undersigned shall complete and submit Standard Form-LLL, "Disclosure Form to Report Lobbying," in accordance with its instructions (as amended by "Government wide Guidance for New Restrictions on Lobbying," 61 Fed. Reg. 1413 (1/19/96). Note: Language in paragraph (2) herein has been modified in accordance with Section 10 of the Lobbying Disclosure Act of 1995 (P.L. 104-65, to be codified at 2 U.S.C. 1601, *et seq.*)

3. The undersigned shall require that the language of this certification be included in the award documents for all subawards at all tiers (including subcontracts, subgrants, and contracts under grants, loans, and cooperative agreements) and that all subrecipients shall certify and disclose accordingly.

This certification is a material representation of fact upon which reliance was placed when this transaction was made or entered into. Submission of this certification is a prerequisite for making or entering into this transaction imposed by 31, U.S.C. § 1352 (as amended by the Lobbying Disclosure Act of 1995). Any person who fails to file the required certification shall be subject to a civil penalty of not less than \$10,000 and not more than \$100,000 for each such failure.

[Note: Pursuant to 31 U.S.C. § 1352(c)(1)-(2)(A), any person who makes a prohibited expenditure or fails to file or amend a required certification or disclosure form shall be subject to a civil penalty of not less than \$10,000 and not more than \$100,000 for each such expenditure or failure.]

The Contractor, Transit Plus, Inc. certifies or affirms the truthfulness and accuracy of each statement of its certification and disclosure, if any. In addition, the Contractor understands and agrees that the provisions of 31 U.S.C. A 3801, *et seq.*, apply to this certification and disclosure, if any.

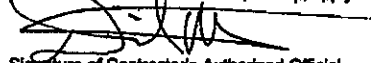

Signature of Contractor's Authorized Official

Name and Title of Contractor's Authorized Official David Morris, Fleet Contracts Mgr.

Date February 11, 2003

TRANSIT VEHICLE MANUFACTURERS (TVM) CERTIFICATION

The proposer, if a transit vehicle manufacturer, hereby certifies that it has complied with the requirements of 49 CFR, Section 23.67 by submitting an annual DBE/WBE goal to the Federal Transit Administration (FTA). The goal has either been approved or not disapproved by FTA.

The proposer, if a non-manufacturer supplier, hereby certifies that the manufacturer of the transit vehicle to be supplied has complied with the above-referenced requirement of 49 CFR~ Section. 23.67.

DATE February 11, 2003

SIGNATURE 

COMPANY NAME Transit Plus, Inc.

TITLE Fleet Contracts Mgr.

MOTOR VEHICLE SAFETY STANDARDS CERTIFICATION

**Certification of Compliance with all safety related items contained in Part 2:
Technical Specifications.**

The Proposer hereby certifies that it shall comply with the safety related requirements contained in **Part 2: Technical Specifications** (reference Federal Register Vol. 47, No. 195, Oct. 7, 1982 FTA Docket Nov. 81-3).

DATE February 11, 2003

SIGNATURE  _____

COMPANY NAME Transit Plus, Inc.

TITLE Fleet Contracts Mgr.

**TITLE VI CIVIL RIGHTS ACT OF 1964
CONTRACTOR AGREEMENT**

During the performance of this Purchasing Agreement, the Contractor, for itself, its assignees and successors in interest (hereinafter referred to as the "Contractor"), agrees as follows:

- (1) **Compliance with Regulations:** The Contractor shall comply with the Regulations relative to nondiscrimination in federally-assisted programs of the Department of Transportation (hereinafter, "DOT") Title 49, Code of Federal Regulations, Part 21.1, as they may be amended from time to time (hereinafter referred to as the Regulations), which are herein incorporated by reference and made a part of this Purchasing Agreement.
- (2) **Nondiscrimination:** The Contractor, with regard to the work performed by it during the Purchasing Agreement, shall not discriminate on the grounds of race, religion, color, sex, age, national origin, or disability in the selection and retention of subcontractors, including procurement of materials and leases of equipment. The Contractor shall not participate either directly or indirectly in the discrimination prohibited by Section 21.5 of the Regulations, including employment practices when the Contract covers a program set forth in Appendix B of the Regulations.
- (3) **Solicitations for Subcontracts, including procurement of materials and equipment:** In all solicitations either by competitive Proposal or negotiation made by the Contractor for work to be performed under a subcontract, including procurement of materials or leases of equipment, each potential subcontractor or supplier shall be notified by the Contractor of the Contractor's obligations under this Purchasing Agreement and the Regulations relative to nondiscrimination on the grounds of race, religion, color, sex, age, national origin, or disability.
- (4) **Information and Reports:** The Contractor shall provide all information and reports required by the Regulations or directives issued pursuant thereto, and shall permit access to its books, records, accounts, other sources of information, and its facilities as may be determined by the Recipient or the FTA to be pertinent to ascertain compliance with such Regulations, orders and instructions. Where any information is required or a Contractor is in the exclusive possession of another who fails or refuses to furnish this information, the Contractor shall so certify to the FVPP, or the FTA, as appropriate, and shall set forth what efforts it has made to obtain the information.

TITLE VI CIVIL RIGHTS ACT OF 1964

CONTRACTOR AGREEMENT

(continued)

(5) **Sanctions for Noncompliance:** In the event of the Contractor's noncompliance with the nondiscrimination provisions of this Purchasing Agreement, the FVPP shall impose such Contract sanctions as it or the FTA may determine to be appropriate, including but not limited to:

- (a) Withholding of payments to the Contractor under the Contract until the Contractor complies, and/or
- (b) Cancellation, termination or suspension of the Purchasing Agreement, in whole or in part.

(6) **Incorporation of Provisions:** The Contractor shall include the provisions of paragraph (1) through (5) of this section in every subcontract, including procurement of materials and leases of equipment, unless exempt by the Regulations, or directives issued pursuant thereto. The Contractor shall take such action with respect to any subcontract or procurement as the FVPP or the FTA may direct as a means of enforcing such provisions including sanctions for noncompliance: Provided, however, that, in the event a Contractor becomes involved in, or is threatened with, litigation with a subcontractor or supplier as a result of such direction, the Contractor may request the FVPP to enter into such litigation to protect the interests of the FVPP, and in addition, the Contractor may request the services of the Attorney General in such litigation to protect the interests of the United States.

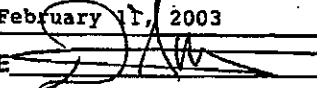
DATE February 11, 2003
SIGNATURE 
COMPANY NAME Transit Plus, Inc.
TITLE Fleet Contracts Mgr.

**CERTIFICATION OF COMPLIANCE WITH
THE AMERICANS WITH DISABILITIES ACT OF 1990**

The Proposer hereby certifies that it shall comply with all requirements contained in Part 2: Technical Specifications relating to bus design or special equipment required by the Americans with Disabilities Act of 1990.

DATE February 11, 2003
SIGNATURE [Signature]
COMPANY NAME Transit Plus, Inc.
TITLE Fleet Contracts Mgr.

DEBARRED BIDDERS / INTEGRITY CERTIFICATION

Certification Regarding Debarment, Suspension, Ineligibility, and Voluntary Exclusion

1. Lower tier participant certifies, by submission of this bid proposal, that neither it nor its "principals" (as defined at 49 CFR Part 29) is presently debarred, suspended, proposed for debarment, declared ineligible, or voluntarily excluded from participating in this transaction by any Federal department or agency.
5. When the prospective lower tier participant is unable to certify to the statements in this certification, such prospective participant shall attach an explanation to this proposal.

DATE: February 11, 2003
COMPANY NAME: Transit Plus, Inc.
SIGNATURE: [Signature]
TITLE: Fleet Contracts Mgr.