

Agenda Item Summary

1. ACTION REQUESTED/PURPOSE: Approve the award of Formal Quote #Q-070204, Annual Purchase of Pelco Products for the Lee County Department of Transportation-Traffic, to all quoters who met all specification requirements, Transportation Control Systems, Temple, Inc. and Traffic Products, Inc. based on the unit pricing listed on the Lee County Tabulation Sheet. The department estimates spending approximately \$100,000. during the next twelve months. The initial term of this quote is one year; also request authority to renew this quote for four additional one-year periods, at the same terms and conditions, if in the best interest of Lee County; and to exercise the price escalator clause as per the specifications on an as-needed basis. In the event that that the low quoter is unable to establish the effectiveness of their product, request the Purchasing Director be given authority to act on behalf of the Board in the event of vendor non-compliance so that the Purchasing Director can proceed to the next low quoter(s). Funding will be available from the individual department or division's budget whom will be responsible for monitoring their individual expenditures.

2. FUNDING SOURCE: Fund-Transportation; Program Traffic - Signals

3. WHAT ACTION ACCOMPLISHES: Establishes competitive, fair market prices for the Pelco Products for the Department of Transportation.

4. MANAGEMENT RECOMMENDATION: Approve.

5. Departmental Category:

C9B

6. Meeting Date: APR 10 2007

7. Agenda:

Consent

Administrative

Appeals

Public

Walk-On

8. Requirement/Purpose: (specify)

Statute

Ordinance

Admin. Code AC-4-1

Other

9. Request Initiated:

Commissioner

Department

Transportation

Division

By: Scott Gilbertson, DOT Director

10. Background: On January 23, 2007, the Division of Purchasing received sealed quotations for the annual purchase of Pelco Products for the Department of Transportation-Traffic Section. On that date, five responses were received; of which two were "No Bids". The quotations have been thoroughly reviewed, and a recommendation is being made to award to Transportation Control Systems, Temple, Inc. and Traffic Products, Inc. as low quoters meeting all specification requirements.

Funding is available: PD5410417500.504635

Please see attachments:

- (1) Tabulation Sheet
- (2) Specifications
- (3) Vendor Quotes
- (4) Department Recommendation

11. Review for Scheduling:

Department Director	Purchasing or Contracts	Human Resources	Other	County Attorney	Budget Services				County Manager/P. W. Director
<i>3/23/07</i>	<i>Naresh Sheehan 3.15.07</i>			<i>3/23/07</i>	Analyst <i>RK 3/26</i>	Risk <i>MF 3/22/07</i>	Grants <i>3/26/07</i>	Mgr. <i>3/26/07</i>	<i>3-23-07</i>

12. Commission Action:

- Approved
- Deferred
- Denied
- Other

Rec. by CoAtty
Date: *3/23/07*
Time: *2:10 pm*
Forwarded To: *2:52 pm*

3-20 PK

**MEMORANDUM
FROM
THE DIVISION OF PURCHASING**

DATE: MARCH 15, 2007

TO: SCOTT GILBERTSON
DOT DIRECTOR

Janet Sheehan
FROM: JANET SHEEHAN, CPPB
PURCHASING DIRECTOR

RE: BLUE SHEET # 20070367

PROJECT: Annual Purchase of Pelco Products

TYPE: Formal Quote

AWARDED TO: Traffic Products, Transportation Control, & Temple

When you have finished your review of this package, please forward it to Jed Schneck in the County Attorney's Office.

If there are any questions or concerns with this package, please contact Judy Cheves at 344-5450.

RECEIVED
MAR 15 2007
TCDOT

FORMAL QUOTATION #Q-070204	LEE COUNTY, FLORIDA TABULATION SHEET				
OPENING DATE: JAN 23, 2007	FOR				
BUYER: JUDY CHEVES	ANNUAL PURCHASE OF PELCO PRODUCTS				
VENDORS	TRANSPORTATION	TRAFFIC	TEMPLE		
	CONTROL	PRODUCTS	INC		
ADDENDA ACKNOWLEDGED	N/A	N/A	N/A		
GRAND TOTAL UNIT COST FOR ITEMS					
1 THRU 68:	\$2,882.00	\$2,981.90	\$2,228.00		
SPECIFY PRICES FOR ITEMS AS LISTED BELOW.					
ALL ITEMS SHALL BE NEW, UNUSED, GENUINE					
PELCO AS SPECIFIED-NO SUBSTITUTES, EQUALS,					
OR REMANUFACTURED/RECONDITIONED					
PRODUCTS ARE ACCEPTABLE.					
DISCRIPTION & PART NUMBER					
1. 12 CIRCUIT DISCONNECT					
PELCO P/N SP-1021-FL-BOX	\$114.00	\$118.00	\$131.00		
2. WING SCREW W/ KEEPER					
PELCO P/N SE-0407-SS	\$2.00	\$1.70	\$2.00		
3. HUB (PELCO) (SHORT)					
PELCO P/N SE-0504	\$8.00	\$8.20	\$9.00		
4. ADJUSTABLE HANGER ASSEMBLY W/ TETHER					
PELCO P/N SP-2027-FL	\$33.00	\$34.00	\$38.00		
5. EXTENDER BAR (6 FT.)					
PELCO P/N SE-0507-72-ALO	\$18.00	\$18.00	\$19.00		
6. TRI-STUD BALANCER ASSEMBLY (3/4" WIDE)					

ATTACHMENT #1

VENDORS	TRANSPORTATION CONTROL	TRAFFIC PRODUCTS	TEMPLE INC		
PELCO P/N SE-5034	\$18.00	\$18.00	\$15.00		
7. SINGLE EYE BALANCER (PIPE)					
PELCO P/N SE-4030	\$12.00	\$12.75	\$14.00		
8. 84" CABLE 3-SEC. ASTRO-BRKT STANDARD ASSEMBLY \$					
PELCO P/N SP-1006-FL-46-84	\$98.00	\$101.00	\$113.00		
9. 84" ASTRO-BRAC. STELLAR W/ SS-CABLE					
PELCO P/N SP-1004-FL-84	\$59.00	\$60.00	\$68.00		
10. 120" SS-CABLE FOR ASTRO-BRAC					
PELCO P/N AB-0320-120	\$28.00	\$26.00	\$29.00		
11. 5 SECTION ASTRO-BRKT. CLUSTER ARM KIT W/ SS-HARDWARE					
PELCO P/N AB-5005-SS	\$111.00	\$110.00	\$112.00		
12. DOUBLE SERRATED LOCK RING					
PELCO P/N SE-0451	\$2.00	\$1.90	\$3.00		
13. 5 SECTION ASTRO B. CLUSTER ASSEMBLY					
PELCO P/N SP-1008-FL-37-84-SS	\$186.00	\$190.00	\$211.00		
14. ASTRO-B. STD. CLAMP KIT					
PELCO P/N SP-1004-FL-84-SS	\$58.00	\$60.00	\$67.00		
15. ASTRO-B. FREE SWING ASSEMBLY					
PELCO P/N AB-3014-84-SS	\$80.00	\$84.50	\$69.00		
16. ASTRO-B. TRI-STUD CLEVIS ADAPTER					
PELCO P/N SE-4031-ALO-SP	\$10.00	\$11.00	\$12.00		
17. HARDWARE KIT, 5-SEC. CLUSTER-SS					
PELCO P/N AB-0322-SS	\$18.00	\$18.00	\$19.00		
18. 5/8" STAINLESS STEEL CLEVIS PIN					
PELCO P/N FS-6000-SS	\$1.00	\$1.00	NO BID		

VENDORS	TRANSPORTATION	TRAFFIC	PRODUCTS	TEMPLE	INC
19. STELLAR SERIES CLAMP KIT - ASTRO BRACKET	\$49.00	\$48.00	\$51.00		
PELCO P/N AS-3004-42-A10					
20. CLAMP SCREW KIT W/HARDWARE	\$4.00	\$4.25	\$13.00		
PELCO P/N AB-0328-SS					
21. U-BOLT KIT, 5/16-18-SS	\$2.00	\$1.40	\$2.00		
PELCO P/N AB-0256-SS					
22. TRI-STUD HARDWARE (W/WASHER & NUTS-SS)	\$7.00	\$6.80	\$3.00		
PELCO P/N SE-5048-SS					
23. TRI-STUD HARDWARE (W/BOLTS-SS)	\$8.00	\$7.70	\$5.00		
PELCO P/N SE-3117-SS					
24. ASTRO-B. STANDARD ARM KIT 9"	\$26.00	\$26.00	\$21.00		
PELCO P/N AB-4000-SS					
25. ASTRO-B. ARM KIT 3M 14"	\$49.00	\$49.00	\$52.00		
PELCO P/N AB-5000-SS					
26. ASTRO-B. TWO WAY UPPER ARM	\$52.00	\$51.00	\$48.00		
PELCO P/N AB-0296-SS					
27. ASTRO-B. TWO WAY LOWER ARM	\$57.00	\$57.00	\$55.00		
PELCO P/N AB-0297-SS					
28. ASTRO-B. UPPER CLUSTER ARM (5 SECTION)	\$54.00	\$54.00	\$51.00		
PELCO P/N AB-0298-SS					
29. ASTRO-B. GUSSETED TUBE KIT	\$19.00	\$18.00	\$20.00		
PELCO P/N AB-2003-46					
30. ASTRO-B. GUSSETED TUBE KIT	\$24.00	\$23.00	\$25.00		
PELCO P/N AB-2003-58					
31. ASTRO-B. TUBE CAP	\$1.00	\$0.80	\$2.00		
PELCO P/N AB-0260-P02					
32. TWO WAY SIGNAL BRACKET (TOP)	\$40.00	\$42.50	\$47.00		
PELCO P/N SP-1026-FL-SS-PXX					
33. TWO WAY SIGNAL BRACKET (BOTTOM)	\$19.00	\$19.50	\$22.00		
PELCO P/N SP-1027-FL-SS					
34. THREE WAY SIGNAL BRACKET (TOP)	\$64.00	\$65.00	\$75.00		
PELCO P/N SP-1015-FL-SS					

VENDORS	TRANSPORTATION CONTROL	TRAFFIC PRODUCTS	TEMPLE INC	
35. THREE WAY SIGNAL BRACKET (BOTTOM) PELCO P/N SP-1016-FL-SS	\$32.00	\$33.00	\$37.00	
36. FOUR WAY SIGNAL BRACKET (TOP) PELCO P/N SP-1017-FL-SS	\$71.00	\$74.00	\$82.00	
37. FOUR WAY SIGNAL BRACKET (BOTTOM) PELCO P/N SP-1018-FL-SS	\$34.00	\$35.00	\$39.00	
38. ASTRO-BRAC, TENON MNT, SIGN BRK. PELCO P/N AB-3010	\$54.00	\$55.00	\$56.00	
39. ASTRO-B. SIGN BRKT. 24" PELCO P/N AB-0283-24-SS	\$18.00	\$17.45	\$19.00	
40. ASTRO-B. SIGN BRKT. 30" PELCO P/N AB-0283-30-SS	\$20.00	\$19.75	\$21.00	
41. SCHOOL FLASHER CAB. MOUNTING KIT ON 4" PIPE PELCO P/N SE-1100	\$23.00	\$21.00	\$23.00	
42. ASTRO MINI SIGN BRACKET W/ 45" CABLE PELCO P/N SP-1072-FL	\$169.00	\$178.00	\$193.00	
43. 3/8" X 4" SIGN CLAMP U-BOLT PELCO P/N SH-0209-SS	\$14.00	\$14.00	\$15.00	****
44. ASTRO-B. SIGN CLAMP W/ HARDWARE PELCO P/N AB-0287-04-SS	\$9.00	\$9.00	\$10.00	****
45. ASTRO-B. SIGN BRKT. 36" PELCO P/N AB-0283-36-SS	\$22.00	\$22.00	\$23.00	
46. ASTRO-B. SIGN BRKT. 72" PELCO P/N AB-0283-72-SS	\$36.00	\$35.00	\$38.00	
47. SPAN WIRE SIGN BRKT. CLAMP ASSEMBLY PELCO P/N SE-0321	\$18.00	\$20.00	\$14.00	
48. 20" SINGLE SPAN DIAGONAL SIGN BRKT PELCO P/N SP-2028-FL	\$63.00	\$75.00	NO BID	***
49. 20" DOUBLE SPAN DIA. SIGN BRKT. ASSY. PELCO P/N: NOT KNOWN - PLEASE SPECIFY	\$95.00	\$99.00	NO BID	***
P/N OF ITEM QUOTED:	SE 5112	SP-2028-FL-SP DOUBLE SIDE		

VENDORS	TRANSPORTATION	TRAFFIC PRODUCTS	TEMPLE INC
50. 6" TETHER CLAMP			
PELCO P/N: NOT KNOWN - PLEASE SPECIFY	\$11.00	NO BID	***
P/N OF ITEM QUOTED:	SP-2042-FL	SP-2043-FL	
51. 7/8" OCTAGONAL CAP (SIGNAL CAP)	\$3.00	\$2.65	\$4.00
PELCO P/N SE-0361			
52. 1-3/8" OCTAGONAL CAP (PED. CAP)	\$5.00	\$4.35	\$5.00
PELCO P/N SE-0483			
53. 5/16"-18 SINGLE STUD HARDWARE KIT			
PELCO P/N SE-5124-SS	\$3.00	\$2.00	NO BID
54. PED. HEAD BRKT. PLATE (CURVED)	\$8.00	\$7.40	\$9.00
PELCO P/N SE-0357			
55. PED. HEAD BRKT. PLATE (FLAT)	\$8.00	\$7.40	\$8.00
PELCO P/N SE-0415			
56. PEDESTRIAN HEAD BRACKET NIPPLE 10-1/2"			
PELCO P/N SE-0436-10-BOX	\$6.00	\$6.30	\$7.00
57. PEDESTRIAN HEAD BRACKET 90 DEGREE ELBOWS			
PELCO P/N SE-0514-SS-BOX	\$13.00	\$13.20	\$14.00
58. PED. PUSH BUTTON ASSEMBLY (POLE)			
PELCO P/N SE-2005-08-M1	\$15.00	\$32.00	\$32.00
59. FLAT BRACKET FOR PED. BUTTON			
PELCO P/N SE-0279-M1	\$5.00	\$4.30	\$5.00
60. PED. PUSH BUTTON SWITCH			
PELCO P/N SE-211-PNC	\$9.00	NO BID	***
61. PED. SQUARE BASE W/ PLASTIC DOOR			
PELCO P/N SP-5326-PXX	\$80.00	\$95.00	NO BID
62. PLASTIC DOOR FOR PED. BASE			
PELCO P/N PB-0543-PNC	\$9.00	\$9.00	\$10.00
63. POLE CAP, DOME TYPE			
PELCO P/N PB-5402	\$7.00	\$7.30	\$8.00
64. COLLAR ASSY. FOR SQ. BASE ALUM.			
PELCO P/N PB-5325	\$40.00	\$40.00	\$45.00
65. SIDE-OF-POLE ASSY., TRI-STUD			



PROJECT NO.: Q-070204

OPEN DATE: JANUARY 23, 2007

AND TIME: 2:30 P.M.

PRE-BID DATE: JANUARY 18, 2007

AND TIME: 10:30 A.M.

LOCATION: LEE COUNTY PURCHASING
1825 HENDRY ST., 3RD FL
FT. MYERS, FL 33901

REQUEST FOR QUOTATIONS

TITLE:

ANNUAL PURCHASE OF PELCO PRODUCTS

REQUESTER: LEE COUNTY BOARD OF COUNTY COMMISSIONERS
DIVISION OF PURCHASING

MAILING ADDRESS

P.O. BOX 398
FORT MYERS, FL 33902-0398

PHYSICAL ADDRESS

1825 Hendry St 3rd Floor
FORT MYERS, FL 33901

BUYER: JUDY CHEVES
PURCHASING AGENT
PHONE NO.: (239) 344-5450

GENERAL CONDITIONS

Sealed Quotations will be received by the DIVISION OF PURCHASING, until 2:30pm on the date specified on the cover sheet of this "Request for Quotations", and opened immediately thereafter by the Purchasing Director or designee.

Any question regarding this solicitation should be directed to the Buyer listed on the cover page of this solicitation, or by calling the Division of Purchasing at (239) 344-5450.

1. **SUBMISSION OF QUOTE:**

a. Quotations shall be sealed in an envelope, and the outside of the envelope should be marked with the following information:

1. Marked with the words "Sealed Quote"
2. Name of the firm submitting the quotation
3. Title of the quotation
4. Quotation number

b. The Quotation shall be submitted in triplicate as follows:

1. The original consisting of the Lee County quotes forms completed and signed.
2. A copy of the original quote forms for the Purchasing Director.
3. A second copy of the original quote forms for use by the requesting department.

c. The following should be submitted along with the quotation in a separate envelope. This envelope should be marked as described above, but instead of marking the envelope as "Sealed Quote", please indicate the contents; i.e., literature, drawings, submittals, etc. This information should be submitted in duplicate.

1. Any information (either required or in addition to that asked for by the specifications) necessary to analyze your quotation; i.e., required submittals, literature, technical data, financial statements.
2. Warranties and guarantees against defective materials and workmanship.

d. **ALTERNATE QUOTE:** If the vendor elects to submit more than one quote, then the quotes should be submitted in separate envelopes and marked as indicated above. The second, or alternate quote should be marked as "Alternate".

- e. **QUOTES RECEIVED LATE:** It is the quoter's responsibility to ensure that his quote is received by the Division of Purchasing prior to the opening date and time specified. Any quote received after the opening date and time will be promptly returned to the quoter unopened. Lee County will not be responsible for quotes received late because of delays by a third party delivery service; i.e., U.S. Mail, UPS, Federal Express, etc.
- f. **QUOTE CALCULATION ERRORS:** In the event there is a discrepancy between the total quoted amount or the extended amounts and the unit prices quoted, the unit prices will prevail and the corrected sum will be considered the quoted price.
- g. **PAST PERFORMANCE:** All vendors will be evaluated on their past performance and prior dealings with Lee County (i.e., failure to meet specifications, poor workmanship, late delivery, etc.).
- h. **WITHDRAWAL OF QUOTE:** No quote may be withdrawn for a period of 90 days after the scheduled time for receiving quotes. A quote may be withdrawn prior to the quote-opening date and time. Such a request to withdraw should be made in writing to the Purchasing Director, who will approve or disapprove of the request.
- i. **COUNTY RESERVES THE RIGHT:** The County reserves the right to waive minor informalities in any quote; to reject any or all quotes with or without cause; and/or to accept the quote that in its judgment will be in the best interest of the County of Lee.
- j. **EXECUTION OF QUOTE:** All quotes shall contain the signature of an authorized representative of the quoter in the space provided on the quote proposal form. All quotes shall be typed or printed in ink. The bidder may not use erasable ink. All corrections made to the quote shall be initialed.

2. **ACCEPTANCE**

The materials and/or services delivered under the quote **shall** remain the property of the seller until a physical inspection and actual usage of these materials and/or services is accepted by the County and is to be in compliance with the terms herein, fully in accord with the specifications and of the highest quality. In the event the materials and/or services supplied to the County are found to be defective or do not conform to specifications, the County reserves the right to cancel the order upon written notice to the seller and return such product to the seller at the seller's expense.

3. **SUBSTITUTIONS**

Whenever in these specifications a brand name or make is mentioned, it is the intention of the County only to establish a grade or quality of materials and not to rule out other brands or makes of equality. However, if a product other than that specified is quote, it is the vendor's responsibility to name such product with his quote and to prove to the County that said product is equal to the product specified. Lee County **shall** be the sole judge as to whether a product being offered by the quoter is actually equivalent to the one being specified by the detailed specifications. (Note: This paragraph does not apply when it is determined that the technical requirements of this solicitation require only a specific product as stated in the detailed specifications.)

4. **RULES, REGULATIONS, LAWS, ORDINANCES & LICENSES**

The awarded vendor shall observe and obey all laws, ordinances, rules, and regulations, of the federal, state, and local government, which may be applicable to the supply of this product or service.

- a. Occupational License – Vendor shall submit within 10 calendar days after request.
- b. Specialty License(s) – Vendor shall possess at the time of the opening of the quote all necessary permits and/or license required for the sale of this product and/or service and upon the request of the County provide copies of licenses and/or permits within 10 calendar days after request.

5. **WARRANTY/GUARANTY** (unless otherwise specified)

All materials and/or services furnished under this quote shall be warranted by the vendor to be free from defects and fit for the intended use.

6. **PRE-BID CONFERENCE**

A pre-bid conference will be held at the location, date, and time specified on the cover of this solicitation. Pre-bid conferences are generally non-mandatory, but it is highly recommended that everyone planning to submit a quote attend.

In the event a pre-bid conference is classified as mandatory, it will be so specified on the cover of this solicitation and it will be the responsibility of the quoter to ensure that they are represented at the pre-bid. Only those quoters who attend the pre-bid conference will be allowed to quote on this project.

7. **BIDDERS LIST MAINTENANCE**

A bidder should respond to "Request for Quotations" in order to be kept on the Bidder's List. Failure to respond to three different "request for quotations" may result in the vendor being removed from the Bidder's List. A bidder may do one of the following, in order to respond properly to the request:

- a. Submission of a quotation prior to the quote receipt deadline.
- b. Submission of a "no bid" notice prior to the quote receipt deadline.

8. **LEE COUNTY PAYMENT PROCEDURES**

All vendors are requested to mail one original invoice and one invoice copy to:

Lee County Finance Department
Post Office Box 2238
Fort Myers, FL 33902-2238

All invoices will be paid as directed by the Lee County payment procedure unless otherwise differently stated in the detailed specification portion of this quote.

Lee county will not be liable for request of payment deriving from aid, assistance, or help by any individual, vendor, quoter, or bidder for the preparation of these specifications.

Lee County is generally a tax-exempt entity subject to the provisions of the 1987 legislation regarding sales tax on services. Lee County will pay those taxes for which it is obligated, or it will provide a Certificate of Exemption furnished by the Department of Revenue. All contractors or quoters should include in their quote all sales or use taxes, which they will pay when making purchases of material or subcontractor's services.

9. **LEE COUNTY BID PROTEST PROCEDURE**

Any contractor/vendor/firm that has submitted a formal bid/quote/proposal to Lee County, and who is adversely affected by an intended decision with respect to the award of the formal bid/quote/proposal, shall file with the County's Purchasing Director or Public Works Director a written "Notice of Intent to File a Protest" not later than seventy-two (72) hours (excluding Saturdays, Sundays and Legal Holidays) after receipt of a "Notice of Intended Decision" from the County with respect to the proposed award of the formal bid/quote/proposal.

The "Notice of Intent to File a Protest" is one of two documents necessary to perfect Protest. The second document is the "Formal Written Protest", both documents are described below.

The "Notice of Intent to File a Protest" document shall state all grounds claimed for the Protest, and clearly indicate it as the "Notice of Intent to File a Protest". Failure to clearly indicate the Intent to file the Protest shall constitute a waiver of all rights to seek any further remedies provided for under this Protest Procedure.

The "Notice of Intent to File a Protest" shall be received ("stamped in") by the Purchasing Director or Public Works Director not later than Four o'clock (4:00) PM on the third working day following the day of receipt of the County's Notice of Intended Decision.

The affected party shall then file its Formal Written Protest within ten (10) calendar days after the time for the filing of the Notice of Intent to File a Protest has expired. Except as provided for in the paragraph below, upon filing of the Formal Written Protest, the contractor/vendor/firm shall post a bond, payable to the Lee County Board of County Commissioners in an amount equal to five percent (5%) of the total bid/quote/proposal, or Ten Thousand Dollars (\$10,000.00), whichever is less. Said bond shall be designated and held for payment of any costs that may be levied against the protesting contractor/vendor/firm by the Board of County Commissioners, as the result of a frivolous Protest.

A clean, Irrevocable Letter of Credit or other form of approved security, payable to the County, may be accepted. Failure to submit a bond, letter of credit, or other approved security simultaneously with the Formal Written Protest shall invalidate the protest, at which time the County may continue its procurement process as if the original "Notice of Intent to File a Protest" had never been filed. Any contractor/vendor/firm submitting the County's standard bond form (CSD: 514), along with the bid/quote/proposal, shall not be required to submit an additional bond with the filing of the Formal Written Protest.

The Formal Written Protest shall contain the following:

- County bid/quote/proposal identification number and title.
- Name and address of the affected party, and the title or position of the person submitting the Protest.
- A statement of disputed issues of material fact. If there are no disputed material facts, the Formal Protest must so indicate.

- A concise statement of the facts alleged, and of the rules, regulations, statues, or constitutional provisions, which entitle the affected party to relief.
- All information, documents, other materials, calculations, and any statutory or case law authority in support of the grounds for the Protest.
- A statement indicating the relief sought by the affected (protesting) party.
- Any other relevant information that the affected party deems to be material to Protest.

Upon receipt of a timely filed "Notice of Intent to File a Protest", the Purchasing Director or Public Works Director (as appropriate) may abate the award of the formal bid/quote/proposal as appropriate, until the Protest is heard pursuant to the informal hearing process as further outlined below, except and unless the County Manager shall find and set forth in writing, particular facts and circumstances that would require an immediate award of the formal bid/quote/proposal for the purpose of avoiding a danger to the public health, safety, or welfare. Upon such written finding by the County Manager, the County Manager may authorize an expedited Protest hearing procedure. The expedited Protest hearing shall be held within ninety-six (96) hours of the action giving rise to the contractor/vendor/firm's Protest, or as soon as may be practicable for all parties. The "Notice of Intent to File a Protest" shall serve as the grounds for the affected party's presentation and the requirements for the submittal of a formal, written Protest under these procedures, to include the requirement for a bond, shall not apply.

The Dispute Committee shall conduct an informal hearing with the protesting contractor/vendor/firm to attempt to resolve the Protest, within seven working days (excluding Saturdays, Sundays and legal holidays) from receipt of the Formal Written Protest. The Chairman of the Dispute Committee shall ensure that all affected parties may make presentations and rebuttals, subject to reasonable time limitations, as appropriate. The purpose of the informal hearing by the Dispute Committee, the protestor and other affected parties is to provide and opportunity: (1) to review the basis of the Protest; (2) to evaluate the facts and merits of the Protest; and (3) to make a determination whether to accept or reject the Protest.

Once a determination is made by the Dispute Committee with respect to the merits of the Protest, the Dispute Committee shall forward to the Board of County Commissioners its recommendations, which shall include relevant background information related to the procurement.

Upon receiving the recommendation from the Dispute Committee, the Board of County Commissioners shall conduct a hearing on the matter at a regularly

scheduled meeting. Following presentations by the affected parties, the Board shall render its decision on the merits of the Protest.

If the Board's decision upholds the recommendation by the Dispute Committee regarding the award, and further finds that the Protest was either frivolous and/or lacked merit, the Board, at its discretion, may assess costs, charges, or damages associated with any delay of the award, or any costs incurred with regard to the protest. These costs, charges or damages may be deducted from the security (bond or letter of credit) provided by the contractor/vendor/firm. Any costs, charges or damages assessed by the Board in excess of the security shall be paid by the protesting contractor/vendor/firm within thirty (30) calendar days of the Board's final determination concerning the award.

All formal bid/quote/proposal solicitations shall set forth the following statement:

“FAILURE TO FOLLOW THE BID PROTEST PROCEDURE REQUIREMENTS WITHIN THE TIMEFRAMES AS PRESCRIBED HEREIN AND ESTABLISHED BY LEE COUNTY BOARD OF COUNTY COMMISSIONERS, FLORIDA, SHALL CONSTITUTE A WAIVER OF YOUR PROTEST AND ANY RESULTING CLAIMS.”

10. **PUBLIC ENTITY CRIME**

Any person or affiliate as defined by statute who has been placed on the convicted vendor list following a conviction for a public entity crime may not submit a bid or a contract to provide any goods or services to the County; may not submit a bid on a contract with the County for the construction or repair of a public building or a public work; may not submit bids or leases of real property to the County; may not be awarded or perform works as a contractor, supplier, subcontractor, or consultant under a contract with the County, and may not transact business with the County in excess of \$25,000.00 for a period of 36 months from the date of being placed on the convicted vendor list.

11. **QUALIFICATION OF QUOTERS** (unless otherwise noted)

Quotes will be considered only from firms normally engaged in the sale and distribution or provision of the services as specified herein. Quoters shall have adequate organization, facilities, equipment, and personnel to ensure prompt and efficient service to Lee County. The County reserves the right before recommending any award to inspect the facilities and organization; or to take any other action necessary to determine ability to perform is satisfactory, and reserves the right to reject quotes where evidence submitted or investigation and evaluation indicates an inability of the quoter to perform.

12. **MATERIAL SAFETY DATA SHEETS**

In accordance with Chapter 443 of the Florida Statutes, it is the vendor's responsibility to provide Lee County with Materials Safety Data Sheets on quoted materials, as may apply to this procurement.

13. **MISCELLANEOUS**

If a conflict exists between the General Conditions and the detailed specifications, then the detailed specifications shall prevail.

14. **WAIVER OF CLAIMS**

Once this contract expires, or final payment has been requested and made, the awarded contractor shall have no more than 30 days to present or file any claims against the County concerning this contract. After that period, the County will consider the Contractor to have waived any right to claims against the County concerning this agreement.

15. **AUTHORITY TO PIGGYBACK**

It is hereby made a precondition of any quote and a part of these specifications that the submission of any quote in response to this request constitutes a quote made under the same conditions, for the same price, and for the same effective period as this quote, to any other governmental entity.

16. **COUNTY RESERVES THE RIGHT**

a) **State Contract**

If applicable, the County reserves the right to purchase any of the items in this quote from State Contract Vendors if the prices are deemed lower on State Contract than the prices we receive in this quotation.

b) **Any Single Large Project**

The County, in its sole discretion, reserves the right to separately quote any project that is outside the scope of this quote, whether through size, complexity, or dollar value.

c) **Disadvantaged Business Enterprises**

The County, in its sole discretion, reserves the right to purchase any of the items in this quote from Disadvantage Business Enterprise vendor if the prices are determined to be in the best interest of the County, to assist the

County in the fulfillment of any of the County's grant commitments to federal or state agencies.

The County further reserves the right to purchase any of the items in this quote from DBE's to fulfill the County's state policy toward DBE's as outlined in County Ordinance 88-45 and 90-04, as amended.

d) Anti-Discrimination

The vendor for itself, its successors in interest, and assignees, as part of the consideration there of covenant and agree that:

In the furnishing of services to the County hereunder, no person on the grounds of race, religion, color, age, sex, national origin, handicap or marital status shall be excluded from participation in, denied the benefits of, or otherwise be subjected to discrimination.

The vendor will not discriminate against any employee or applicant for employment because of race, religion, color, age, sex, national origin, handicap or marital status. The vendor will make affirmative efforts to insure that applicants are employed and that employees are treated during employment without regard to their race, religion, color, age, sex, national origin, handicap or marital status. Such action shall include, but not be limited to, acts of employment, upgrading, demotion or transfer; recruitment advertising; layoff or termination, rates of pay or other forms of compensation and selection for training, including apprenticeship.

Vendor agrees to post in a conspicuous place, available to employees and applicants for employment, notices setting forth the provisions of this anti-discrimination clause.

Vendor will provide all information and reports required by relevant regulations and/or applicable directives. In addition, the vendor shall permit access to its books, records, accounts, other sources of information, and its facilities as may be determined by the County to be pertinent to ascertain compliance. The vendor shall maintain and make available relevant data showing the extent to which members of minority groups are beneficiaries under these contracts.

Where any information required of the vendor is in the exclusive possession of another who fails or refuses to furnish this information, the vendor shall so certify to the County its effort made toward obtaining said information. The vendor shall remain obligated under this paragraph until the expiration of three (3) years after the termination of this contract.

In the event of breach of any of the above anti-discrimination covenants, the County shall have the right to impose sanctions as it may determine to be appropriate, including withholding payment to the vendor or canceling, terminating, or suspending this contract, in whole or in part.

Additionally, the vendor may be declared ineligible for further County contracts by rule, regulation or order of the Board of County Commissioners of Lee County, or as otherwise provided by law.

The vendor will send to each union, or representative of workers with which the vendor has a collective bargaining agreement or other contract of understanding, a notice informing the labor union of worker's representative of the vendor's commitments under this assurance, and shall post copies of the notice in conspicuous places available to the employees and the applicants for employment.

The vendor will include the provisions of this section in every subcontract under this contract to insure its provisions will be binding upon each subcontractor. The vendor will take such actions with respect to any subcontractor, as the contracting agency may direct, as a means of enforcing such provisions, including sanctions for non-compliance.

17. **AUDITABLE RECORDS**

The awarded vendor shall maintain auditable records concerning the procurement adequate to account for all receipts and expenditures, and to document compliance with the specifications. These records shall be kept in accordance with generally accepted accounting methods, and Lee County reserves the right to determine the record-keeping method required in the event of non-conformity. These records shall be maintained for two years after completion of the project and shall be readily available to County personnel with reasonable notice, and to other persons in accordance with the Florida Public Disclosure Statutes.

18. **DRUG FREE WORKPLACE**

Whenever two or more quotes/proposals, which are equal with respect to price, quality and service, are received for the procurement of commodities or contractual services, a quote/proposal received from a business that certifies that it has implemented a drug-free workplace program shall be given preference in the award process. In order to have a drug-free workplace program, a business shall comply with the requirements of Florida Statutes 287.087.

19. **REQUIRED SUBMITTALS**

Any submittals requested should be returned with the quote response. This information may be accepted after opening, but no later than 10 calendar days after request.

20. **TERMINATION**

Any agreement as a result of this quote may be terminated by either party giving thirty (30) calendar days advance written notice. The County reserves the right to accept or not accept a termination notice submitted by the vendor, and no such termination notice submitted by the vendor shall become effective unless and until the vendor is notified in writing by the County of its acceptance.

The Purchasing Director may immediately terminate any agreement as a result of this quote for emergency purposes, as defined by the Lee County Purchasing and Payment Procedure Manual.

Any vendor who has voluntarily withdrawn from a formal quote/proposal without the County's mutual consent during the contract period shall be barred from further County procurement for a period of 180 days. The vendor may apply to the Board of Lee County Commissioners for waiver of this debarment. Such application for waiver of debarment must be coordinated with and processed by Purchasing.

21. **CONFIDENTIALITY**

Vendors should be aware that all submittals (including financial statements) provided with a quote/proposal are subject to public disclosure and will **not** be afforded confidentiality.

22. **ANTI-LOBBYING CLAUSE**

All firms are hereby placed on formal notice that neither the County Commissioners nor candidates for County Commission, nor any employees from the Lee County Government, Lee County staff members, nor any members of the Qualification/Evaluation Review Committee are to be lobbied, either individually or collectively, concerning this project. Firms and their agents who intend to submit qualifications, or have submitted qualifications, for this project are hereby placed on *formal notice* that they are ***not*** to contact County personnel for such purposes as holding meetings of introduction, meals, or meetings relating to the selection process outside of those specifically scheduled by the County for negotiations. Any such lobbying activities may cause immediate disqualification for this project.

23. **INSURANCE (AS APPLICABLE)**

Insurance shall be provided, per the attached insurance guide. Upon request, an insurance certificate complying with the attached guide may be required prior to award.

**LEE COUNTY, FLORIDA
PROPOSAL QUOTE FORM
FOR THE ANNUAL PURCHASE OF PELCO PRODUCTS**

DATE SUBMITTED: _____

VENDOR NAME: _____

TO: The Board of County Commissioners
Lee County
Fort Myers, Florida

Having carefully examined the "General Conditions", and the "Detailed Specifications", all of which are contained herein, the Undersigned proposes to furnish the following which meet these specifications:

The undersigned acknowledges receipt of Addenda numbers:

GRAND TOTAL UNIT COST FOR ITEMS 1 THRU 68:

\$ _____

SPECIFY PRICES FOR ITEMS AS LISTED BELOW. ALL ITEMS SHALL BE NEW, UNUSED, GENUINE PELCO AS SPECIFIED – NO SUBSTITUTES, EQUALS, OR REMANUFACTURED/RECONDITIONED PRODUCTS ARE ACCEPTABLE.

<u>DESCRIPTION & PART NUMBER</u>	<u>UNIT COST</u>
1. 12 CIRCUIT DISCONNECT PELCO P/N SP-1021-FL-BOX	\$ _____
2. WING SCREW W/ KEEPER PELCO P/N SE-0407-SS	\$ _____
3. HUB (PELCO) (SHORT) PELCO P/N SE-0504	\$ _____
4. ADJUSTABLE HANGER ASSEMBLY W/ TETHER PELCO P/N SP-2027-FL	\$ _____

<u>DESCRIPTION & PART NUMBER</u>	<u>UNIT COST</u>
5. EXTENDER BAR (6 FT.) PELCO P/N SE-0507-72-ALO	\$ _____
6. TRI-STUD BALANCER ASSEMBLY (3/4" WIDE) PELCO P/N SE-5034	\$ _____
7. SINGLE EYE BALANCER (PIPE) PELCO P/N SE-4030	\$ _____
8. 84" CABLE 3-SEC. ASTRO-BRKT STANDARD ASSEMBLY PELCO P/N SP-1006-FL-46-84	\$ _____
9. 84" ASTRO-BRAC. STELLAR W/ SS-CABLE PELCO P/N SP-1004-FL-84	\$ _____
10. 120" SS-CABLE FOR ASTRO-BRAC PELCO P/N AB-0320-120	\$ _____
11. 5 SECTION ASTRO-BRKT. CLUSTER ARM KIT W/ SS-HARDWARE PELCO P/N AB-5005-SS	\$ _____
12. DOUBLE SERRATED LOCK RING PELCO P/N SE-0451	\$ _____
13. 5 SECTION ASTRO B. CLUSTER ASSEMBLY PELCO P/N SP-1008-FL-37-84-SS	\$ _____
14. ASTRO-B. STD. CLAMP KIT PELCO P/N SP-1004-FL-84-SS	\$ _____
15. ASTRO-B. FREE SWING ASSEMBLY PELCO P/N AB-3014-84-SS	\$ _____
16. ASTRO-B. TRI-STUD CLEVIS ADAPTER PELCO P/N SE-4031-ALO-SP	\$ _____
17. HARDWARE KIT, 5-SEC. CLUSTER-SS PELCO P/N AB-0322-SS	\$ _____
18. 5/8" STAINLESS STEEL CLEVIS PIN PELCO P/N FS-6000-SS	\$ _____
19. STELLAR SERIES CLAMP KIT – ASTRO BRACKET PELCO P/N AS-3004-42-ALO	\$ _____
20. CLAMP SCREW KIT W/ HARDWARE PELCO P/N AB-0328-SS	\$ _____

<u>DESCRIPTION & PART NUMBER</u>	<u>UNIT COST</u>
21. U-BOLT KIT, 5/16-18-SS PELCO P/N AB-0256-SS	\$ _____
22. TRI-STUD HARDWARE (W/ WASHER & NUTS-SS) PELCO P/N SE-5048-SS	\$ _____
23. TRI-STUD HARDWARE (W/ BOLTS-SS) PELCO P/N SE-3117-SS	\$ _____
24. ASTRO-B. STANDARD ARM KIT 9" PELCO P/N AB-4000-SS	\$ _____
25. ASTRO-B. ARM KIT 3M 14" PELCO P/N AB-5000-SS	\$ _____
26. ASTRO-B. TWO WAY UPPER ARM PELCO P/N AB-0296-SS	\$ _____
27. ASTRO-B. TWO WAY LOWER ARM PELCO P/N AB-0297-SS	\$ _____
28. ASTRO-B. UPPER CLUSTER ARM (5 SECTION) PELCO P/N AB-0298-SS	\$ _____
29. ASTRO-B. GUSSETED TUBE KIT PELCO P/N AB-2003-46	\$ _____
30. ASTRO-B. GUSSETED TUBE KIT PELCO P/N AB-2003-58	\$ _____
31. ASTRO-B. TUBE CAP PELCO P/N AB-0260-P02	\$ _____
32. TWO WAY SIGNAL BRACKET (TOP) PELCO P/N SP-1026-FL-SS-PXX	\$ _____
33. TWO WAY SIGNAL BRACKET (BOTTOM) PELCO P/N SP-1027-FL-SS	\$ _____
34. THREE WAY SIGNAL BRACKET (TOP) PELCO P/N SP-1015-FL-SS	\$ _____
35. THREE WAY SIGNAL BRACKET (BOTTOM) PELCO P/N SP-1016-FL-SS	\$ _____
36. FOUR WAY SIGNAL BRACKET (TOP) PELCO P/N SP-1017-FL-SS	\$ _____

<u>DESCRIPTION & PART NUMBER</u>	<u>UNIT COST</u>
37. FOUR WAY SIGNAL BRACKET (BOTTOM) PELCO P/N SP-1018-FL-SS	\$ _____
38. ASTRO-BRAC, TENON MNT, SIGN BRK. PELCO P/N AB-3010	\$ _____
39. ASTRO-B. SIGN BRKT. 24" PELCO P/N AB-0283-24-SS	\$ _____
40. ASTRO-B. SIGN BRKT. 30" PELCO P/N AB-0283-30-SS	\$ _____
41. SCHOOL FLASHER CAB. MOUNTING KIT ON 4" PIPE PELCO P/N SE-1100	\$ _____
42. ASTRO MINI SIGN BRACKET W/ 45" CABLE PELCO P/N SP-1072-FL	\$ _____
43. 3/8" X 4" SIGN CLAMP U-BOLT PELCO P/N SH-0209-SS	\$ _____
44. ASTRO-B. SIGN CLAMP W/ HARDWARE PELCO P/N AB-0287-04-SS	\$ _____
45. ASTRO-B. SIGN BRKT. 36" PELCO P/N AB-0283-36-SS	\$ _____
46. ASTRO-B. SIGN BRKT. 72" PELCO P/N AB-0283-72-SS	\$ _____
47. SPAN WIRE SIGN BRKT. CLAMP ASSEMBLY PELCO P/N SE-0321	\$ _____
48. 20" SINGLE SPAN DIAGONAL SIGN BRKT PELCO P/N SP-2028-FL	\$ _____
49. 20" DOUBLE SPAN DIA. SIGN BRKT. ASSY. PELCO P/N: NOT KNOWN – PLEASE SPECIFY P/N OF ITEM QUOTED: _____	\$ _____
50. 6" TETHER CLAMP PELCO P/N: NOT KNOWN – PLEASE SPECIFY P/N OF ITEM QUOTED: _____	\$ _____
51. 7/8" OCTAGONAL CAP (SIGNAL CAP) PELCO P/N SE-0361	\$ _____
52. 1-3/8" OCTAGONAL CAP (PED. CAP) PELCO P/N SE-0483	\$ _____

<u>DESCRIPTION & PART NUMBER</u>	<u>UNIT COST</u>
53. 5/16"-18 SINGLE STUD HARDWARE KIT PELCO P/N SE-5124-SS	\$ _____
54. PED. HEAD BRKT. PLATE (CURVED) PELCO P/N SE-0357	\$ _____
55. PED. HEAD BRKT. PLATE (FLAT) PELCO P/N SE-0415	\$ _____
56. PEDESTRIAN HEAD BRACKET NIPPLE 10-1/2" PELCO P/N SE-0436-10-BOX	\$ _____
57. PEDESTRIAN HEAD BRACKET 90 DEGREE ELBOWS PELCO P/N SE-0514-SS-BOX	\$ _____
58. PED. PUSH BUTTON ASSEMBLY (POLE) PELCO P/N SE-2005-08-M1	\$ _____
59. FLAT BRACKET FOR PED. BUTTON PELCO P/N SE-0279-M1	\$ _____
60. PED. PUSH BUTTON SWITCH PELCO P/N SE-211-PNC	\$ _____
61. PED. SQUARE BASE W/ PLASTIC DOOR PELCO P/N SP-5326-PXX	\$ _____
62. PLASTIC DOOR FOR PED. BASE PELCO P/N PB-0543-PNC	\$ _____
63. POLE CAP, DOME TYPE PELCO P/N PB-5402	\$ _____
64. COLLAR ASSY. FOR SQ. BASE ALUM. PELCO P/N PB-5325	\$ _____
65. SIDE-OF-POLE ASSY., TRI-STUD PELCO P/N SP-1078-FL	\$ _____
66. TRI-STUD SLIP FITTER PELCO P/N SP-1034-FL	\$ _____
67. ADJUSTABLE CANTILEVER ARM PELCO P/N SP-1001-FL	\$ _____
68. TRI-STUD ADAPTER PELCO P/N SE-0503	\$ _____

GRAND TOTAL UNIT COST FOR ITEMS 1 THRU 68:

\$ _____

WILL YOU DELIVER WITH YOUR OWN VEHICLES AS OPPOSED TO COMMON CARRIER?

YES _____ NO _____

TO BE DELIVERED WITHIN _____ CALENDAR DAYS AFTER RECEIPT OF AWARD AND PURCHASE ORDER.

Is your firm interested in being considered for the Local Vendor Preference?

Yes _____ No _____

If yes, then read the paragraph entitled "Local Vendor Preference" included in these specifications. Also complete the Local Vendor Preference Questionnaire and return with your quotation.

Quoters should carefully read all the terms and conditions of the specifications. Any representation of deviation or modification to the quote may be grounds to reject the quote.

Are there any modifications to the quote or specifications:

Yes _____ No _____

Failure to clearly identify any modifications in the space below or on a separate page may be grounds for the quoter being declared nonresponsive or to have the award of the quote rescinded by the County.

MODIFICATIONS:

Quoter shall submit his/her quote on the County's Proposal Quote Form, including the firm name and authorized signature. Any blank spaces on the Proposal Quote Form, qualifying notes or exceptions, counter offers, lack of required submittals, or signatures, on County's Form may result in the Quoter/Quote being declared non-responsive by the County.

ANTI-COLLUSION STATEMENT

THE BELOW SIGNED QUOTER HAS NOT DIVULGED TO, DISCUSSED OR COMPARED HIS QUOTE WITH OTHER QUOTERS AND HAS NOT COLLUDED WITH ANY OTHER QUOTER OR PARTIES TO A QUOTE WHATSOEVER. NOTE: NO PREMIUMS, REBATES OR GRATUITIES TO ANY EMPLOYEE OR AGENT ARE PERMITTED EITHER WITH, PRIOR TO, OR AFTER ANY DELIVERY OF MATERIALS. ANY SUCH VIOLATION WILL RESULT IN THE CANCELLATION AND/OR RETURN OF MATERIAL (AS APPLICABLE) AND THE REMOVAL FROM THE MASTER BIDDERS LIST.

FIRM NAME _____

BY (Printed): _____

BY (Signature): _____

TITLE: _____

FEDERAL ID # OR S.S.# _____

ADDRESS: _____

PHONE NO.: _____

FAX NO.: _____

CELLULAR PHONE/PAGER NO.: _____

LEE COUNTY OCCUPATIONAL LICENSE NUMBER: _____

E-MAIL ADDRESS: _____

REVISED: 7/28/00

**LEE COUNTY, FLORIDA
DETAILED SPECIFICATIONS FOR THE
ANNUAL PURCHASE OF PELCO PRODUCTS**

SCOPE

It is the intent of these specifications to establish a quote for the Lee County Department of Transportation - Traffic Division, for the purchase Pelco Products throughout the year on an as needed basis.

TERM OF QUOTE

This quote shall be in effect for one year, or until new quotes are taken and awarded. This quote or any portion thereof, has the option of being renewed for four additional one-year periods, upon mutual agreement of both parties, under the same terms and conditions.

QUANTITY PRICE BREAKS

If your firm can offer quantity price breaks to Lee County on any items listed, specify item(s), quantity breaks and pricing on company letterhead. The prices offered on the Proposal Quote Form will form the basis of award.

REGULAR DEALER

Quotes will be considered only from firms which qualify as a "regular dealer".

A "regular dealer" means a firm that owns, operates, or maintains a store, warehouse, or other establishment in which the materials or supplies required for the performance of the contract are bought, kept in stock, and regularly sold to the public in the usual course of business. To be a regular dealer, the firm must engage in, as its principal business and in its own name, the purchase and sale of the products in question.

DESIGNATED CONTACT

The awarded vendor shall appoint a person or persons to act as a primary contact for all county departments. This person or back-up shall be readily available during normal work hours by phone or in person, and shall be knowledgeable of the terms and procedures involved in this quotation.

SUMMARY REPORTS

Upon completion of each six month period of the quote, the awarded vendor shall be responsible for furnishing a summary report to Purchasing. This report shall include the previous six months history, showing at a minimum, the following information:

- 1) Total dollars expended per item,
- 2) Total quantity of each item purchased.

SUBMITTALS

After opening, quoters may be requested to submit descriptive literature and/or specification sheets indicating the products quoted meet the specifications herein. If requested, quoters shall furnish this information within 5 calendar days.

BASIS OF AWARD

This quote will be awarded either to the overall low quoter meeting specifications, or the low quoter meeting specifications per item, at Lee County's sole discretion. Lee County may give preference to vendors who quote all line items.

Lee County reserves the right, at the Purchasing Director's discretion, not to award certain items listed on the Proposal Quote Form. Lee County reserves the right to reject unbalanced quotes.

DELIVERY REQUIREMENTS

All quotes shall be based on firm prices delivered F.O.B. to the Lee County DOT – Traffic Division, 5650 Enterprise Parkway, Fort Myers, Florida 33905, or other Fort Myers locations, as directed. Delivery hours are Monday to Thursday between 8:00 a.m. and 4:00 p.m.

Lee County reserves the right to purchase from another vendor, if the awarded vendor fails to deliver items within the specified time.

ESTIMATED VOLUME

Lee County estimates spending approximately \$100,000 for Pelco Products annually. This figure is given for quoter's guidance only, and no minimum amount is guaranteed or implied.

PRICE ESCALATION/DE-ESCALATION

Offers are submitted with the understanding that no price increases will be authorized for 365 calendar days after the effective date of the contract. Upward price adjustments may be permitted only at the end of this period and each 30-day period thereafter and only where verified to the satisfaction of the Division of Purchasing as provided herein. **However, "across the board" price decreases are subject to implementation at any time and shall be immediately conveyed to the County.**

The awarded vendor(s) shall not give less than 30 days advance written notice of a price increase to the Division of Purchasing. Any approved price change will be effective only at the beginning of the calendar month following the end of the full 30-day notification period. The vendor shall document the amount and proposed effective date of the change in price. The price change must affect all accounts serviced by the vendor. Documentation shall be supplied with vendor's request for increase which will: (1) verify that the requested price increase is general in scope and not applicable just to the County; and (2) verify the amount or percentage of increase which is being passed on to the vendor by others not under the control of the vendor. Failure by the vendor to supply the aforementioned verification with the request for price increase will result in delay of the effective date of such increase. The Division of Purchasing may make such verification as deemed adequate. However, an increase, which the Division of Purchasing determines is excessive, regardless of any documentation supplied by the vendor, may be cause for cancellation of the contract by the Division of Purchasing. The Division of Purchasing will notify using

agencies and vendor in writing of the effective date of any increase, which is approved. However, the Vendor shall fill all purchase orders received prior to the effective date of the price adjustment at the old contract prices. The Vendor is further advised that price decreases that affect the cost of materials, labor, and transportation are required to be passed on to the County immediately. Failure to do so will result in action to recoup such amounts.

AFFIDAVIT CERTIFICATION IMMIGRATION LAWS

The attached document, Affidavit Certification Immigration Laws, is required and should be submitted with your quotation package. It must be signed and notarized. Failure to include this affidavit with your quote will delay the consideration and review of your submission; and could result in your quote response being disqualified.

LOCAL BIDDER'S PREFERENCE

Note: In order for your firm to be considered for the local vendor preference, you must complete and return the attached "Local Vendor Preference Questionnaire" with your quotation.

The Lee County Local Bidder's Preference Ordinance No. 00-10 is being included as part of the award process for this project. As such, Lee County at its sole discretion, may choose to award a preference to any qualified "Local Contractor/Vendor" in an amount not to exceed 3 % of the total amount quoted by that firm.

"Local Contractor / Vendor" shall mean: a) any person, firm, partnership, company or corporation whose principal place of business in the sole opinion of the County, is located within the boundaries of Lee County, Florida; or b) any person, firm, partnership, company or corporation that has provided goods or services to Lee County on a regular basis for the preceding consecutive five (5) years, and that has the personnel, equipment and materials located within the boundaries of Lee County sufficient to constitute a present ability to perform the service or provide the goods.

The County reserves the exclusive right to compare, contrast and otherwise evaluate the qualifications, character, responsibility and fitness of all persons, firms, partnerships, companies or corporations submitting formal bids or formal quotes in any procurement for goods or services when making an award in the best interests of the County.

ATTACHMENT A
LOCAL VENDOR PREFERENCE QUESTIONNAIRE
(LEE COUNTY ORDINANCE NO. 00-10)

Instructions: Please complete either Part A or B whichever is applicable to your firm

PART A: VENDOR'S PRINCIPAL PLACE OF BUSINESS IS LOCATED WITHIN LEE COUNTY (Only complete Part A if your principal place of business is located within the boundaries of Lee County)

1. What is the physical location of your principal place of business that is located within the boundaries of Lee County, Florida?

2. What is the size of this facility (i.e. sales area size, warehouse, storage yard, etc.)

PART B: VENDOR'S PRINCIPAL PLACE OF BUSINESS IS NOT LOCATED WITHIN LEE COUNTY OR DOES NOT HAVE A PHYSICAL LOCATION WITHIN LEE COUNTY (Please complete this section.)

1. How many employees are available to service this contract? _____

2. Describe the types and amount of equipment you have available to service this contract.

LOCAL VENDOR PREFERENCE QUESTIONNAIRE CONTINUED

3. Describe the types and amount of material stock that you have available to service this contract.

4. Have you provided goods or services to Lee County on a regular basis for the preceding, consecutive five years?

Yes _____ No _____

If yes, please provide your contractual history with Lee County for the past five, consecutive years. Attach additional pages if necessary.

AFFIDAVIT CERTIFICATION
IMMIGRATION LAWS

SOLICITATION NO.: _____ PROJECT NAME: _____

LEE COUNTY WILL NOT INTENTIONALLY AWARD COUNTY CONTRACTS TO ANY CONTRACTOR WHO KNOWINGLY EMPLOYS UNAUTHORIZED ALIEN WORKERS, CONSTITUTING A VIOLATION OF THE EMPLOYMENT PROVISIONS CONTAINED IN 8 U.S.C. SECTION 1324 a(e) {SECTION 274A(e) OF THE IMMIGRATION AND NATIONALITY ACT ("INA").

LEE COUNTY MAY CONSIDER THE EMPLOYMENT BY ANY CONTRACTOR OF UNAUTHORIZED ALIENS A VIOLATION OF SECTION 274A(e) OF THE INA. **SUCH VIOLATION BY THE RECIPIENT OF THE EMPLOYMENT PROVISIONS CONTAINED IN SECTION 274A(e) OF THE INA SHALL BE GROUNDS FOR UNILATERAL CANCELLATION OF THE CONTRACT BY LEE COUNTY.**

BIDDER ATTESTS THAT THEY ARE FULLY COMPLIANT WITH ALL APPLICABLE IMMIGRATION LAWS (SPECIFICALLY TO THE 1986 IMMIGRATION ACT AND SUBSEQUENT AMENDMENTS).

Company Name: _____

Signature Title Date

STATE OF _____
COUNTY OF _____

The foregoing instrument was signed and acknowledged before me this _____ day of _____, 20____, by _____ who has produced (Print or Type Name) _____ as identification. (Type of Identification and Number)

Notary Public Signature

Printed Name of Notary Public

Notary Commission Number/Expiration

The signee of this Affidavit guarantees, as evidenced by the sworn affidavit required herein, the truth and accuracy of this affidavit to interrogatories hereinafter made. **LEE COUNTY RESERVES THE RIGHT TO REQUEST SUPPORTING DOCUMENTATION, AS EVIDENCE OF SERVICES PROVIDED, AT ANY TIME.**

INSURANCE REQUIREMENTS

NOTE: Your certificate of insurance must meet the following requirements:

Requirement #1:

The Lee County Board of County Commissioners shall be added as an additional insured on the comprehensive general liability policy.

Requirement #2:

Certificate holder shall be listed as follows:

Lee County Board of County Commissioners
C/O Lee County Purchasing
P.O. Box 398
Fort Myers, FL 33902-0398

Requirement #3:

Each policy shall provide a 30-day notification clause in the event of cancellation, non-renewal or adverse change.

1. **Minimum Insurance Requirements:** *Risk Management in no way represents that the insurance required is sufficient or adequate to protect the vendor's interest or liabilities, but are merely minimums.*
 - a. **Workers' Compensation** - Statutory benefits as defined by FS 440 encompassing all operations contemplated by this contract or agreement to apply to all owners, officers, and employees regardless of the number of employees. Individual employees may be exempted per State Law. Employers' liability will have minimum limits of:

\$500,000 per accident
\$500,000 disease limit
\$500,000 disease limit per employee
 - b. **Commercial General Liability** - Coverage shall apply to premises and/or operations, products and/or completed operations, independent contractors, contractual liability, and exposures with minimum limits of:

\$500,000 bodily injury per person (BI)
\$1,000,000 bodily injury per occurrence (BI)
\$500,000 property damage (PD) or
\$1,000,000 combined single limit (CSL) of BI and PD

- c. Business Auto Liability - The following Automobile Liability will be required and coverage shall apply to all owned, hired and non-owned vehicles use with minimum limits of:

\$500,000 bodily injury per person (BI)
\$1,000,000 bodily injury per occurrence (BI)
\$100,000 property damage (PD) or
\$1,000,000 combined single limit (CSL) of BI and PD

****The required limit of liability shown in Standard Contract: 1.a; 1.b; 1.c; may be provided in the form of "Excess Insurance" or "Commercial Umbrella Policies." In which case, a "Following Form Endorsement" will be required on the "Excess Insurance Policy" or "Commercial Umbrella Policy."***

2. Verification of Coverage:

- a. Ten (10) days prior to the commencement of any work under this contract a certificate of insurance will be provided to the Risk Manager for review and approval. The certificate shall provide for the following:

1. ***"Lee County, a political subdivision and Charter County of the State of Florida, its agents, employees, and public officials@ will be named as an "Additional Insured" on the General Liability policy.***
2. Lee County will be given thirty (30) days notice prior to cancellation or modification of any stipulated insurance. Such notification will be in writing by registered mail, return receipt requested and addressed to the Risk Manager (P.O. BOX 398 Ft. Myers, FL 33902).

3. Special Requirements:

- a. It is the responsibility of the general contractor to insure that all subcontractors comply with all insurance requirements.

To the fullest extent permitted by applicable law, Contractor shall protect, defend, indemnify, save and hold the County, the Board of County Commissioners, its agents, officials, and employees harmless from and against any and all claims, demands, fines, loss or destruction of property, liabilities, damages, for claims based on the negligence, misconduct, or omissions of the Contractor resulting from the Contractor's work as further described in this contract, which may arise in favor of any person or persons resulting from the Contractor's performance or non-performance of its obligations under this contract except any damages arising out of personal injury or property claims from third parties caused solely by the negligence, omission(s) or willful misconduct of the County, its officials, commissions, employees or agents, subject to the limitations as set out in Florida general law, Section 768.28, Florida Statutes, as amended. Further, Contractor hereby agrees to indemnify the County for all reasonable expenses and attorney's fees incurred by or imposed upon the County in connection therewith for any loss, damage, injury or other casualty. Contractor additionally agrees that the County may employ an attorney of the County's own selection to appear and defend any such action, on behalf of the County, at the expense of the Contractor. The Contractor further agrees to pay all reasonable expenses and attorney's fees incurred by the County in establishing the right to indemnity.

LEE COUNTY PURCHASING - BIDDERS CHECK LIST

IMPORTANT: Please read carefully and return with your bid proposal.

Please check off each of the following items as the necessary action is completed:

- ___ 1. The Quote has been signed.
- ___ 2. The Quote prices offered have been reviewed.
- ___ 3. The price extensions and totals have been checked.
- ___ 4. The original (must be manually signed) and 2 copies of the quote have been submitted.
- ___ 5. Three (3) identical sets of descriptive literature, brochures and/or data (if required) have been submitted under separate cover.
- ___ 6. All modifications have been acknowledged in the space provided.
- ___ 7. All addendums issued, if any, have been acknowledged in the space provided.
- ___ 8. Erasures or other changes made to the quote document have been initialed by the person signing the quote.
- ___ 9. Bid Bond and/or certified Check, (if required) have been submitted with the quote in amounts indicated.
- ___ 10. Any Delivery information required is included.
- ___ 11. Affidavit Certification Immigration Signed and Notarized
- ___ 12. The mailing envelope has been addressed to:

MAILING ADDRESS	or	PHYSICAL ADDRESS
Lee County Purchasing		Lee County Purchasing
P.O. Box 398		1825 Hendry St 3 rd Floor
Ft. Myers, FL 33902-0398		Ft. Myers, FL 33901
- ___ 13. The mailing envelope **MUST** be sealed and marked with:
 - Quote Number
 - Opening Date and/or Receiving Date
- ___ 14. The quote will be mailed or delivered in time to be received no later than the specified opening date and time. (Otherwise quote cannot be considered or accepted.)
- ___ 15. If submitting a "NO BID" please write quote number here _____ and check one of the following:
 - ___ Do not offer this product ___ Insufficient time to respond.
 - ___ Unable to meet specifications (why)
 - ___ Unable to meet bond or insurance requirement.
 - Other: _____

Company Name and Address:

ATTACHMENT #3

FORMAL QUOTE NO.: Q-070204

**LEE COUNTY, FLORIDA
PROPOSAL QUOTE FORM
FOR THE ANNUAL PURCHASE OF PELCO PRODUCTS**

DATE SUBMITTED: 1/22/07

VENDOR NAME: Traffic Products, Inc.

TO: The Board of County Commissioners
Lee County
Fort Myers, Florida

Having carefully examined the "General Conditions", and the "Detailed Specifications", all of which are contained herein, the Undersigned proposes to furnish the following which meet these specifications:

The undersigned acknowledges receipt of Addenda numbers: None

GRAND TOTAL UNIT COST FOR ITEMS 1 THRU 68:

\$2,981.90

SPECIFY PRICES FOR ITEMS AS LISTED BELOW. ALL ITEMS SHALL BE NEW, UNUSED, GENUINE PELCO AS SPECIFIED - NO SUBSTITUTES, EQUALS, OR REMANUFACTURED/RECONDITIONED PRODUCTS ARE ACCEPTABLE.

<u>DESCRIPTION & PART NUMBER</u>	<u>UNIT COST</u>
1. 12 CIRCUIT DISCONNECT PELCO P/N SP-1021-FL-BOX	\$ <u>118.⁰⁰</u>
2. WING SCREW W/ KEEPER PELCO P/N SE-0407-SS	\$ <u>1.70</u>
3. HUB (PELCO) (SHORT) PELCO P/N SE-0504	\$ 8.20 <u>8.20</u>
4. ADJUSTABLE HANGER ASSEMBLY W/ TETHER PELCO P/N SP-2027-FL	\$ <u>34.⁰⁰</u>

23. **INSURANCE (AS APPLICABLE)**

Insurance shall be provided, per the attached insurance guide. Upon request, an insurance certificate complying with the attached guide may be required prior to award.

<u>DESCRIPTION & PART NUMBER</u>	<u>UNIT COST</u>
5. EXTENDER BAR (6 FT.) PELCO P/N SE-0507-72-ALO	\$ <u>18.⁰⁰</u>
6. TRI-STUD BALANCER ASSEMBLY (3/4" WIDE) PELCO P/N SE-5034	\$ <u>18.⁰⁰</u>
7. SINGLE EYE BALANCER (PIPE) PELCO P/N SE-4030	\$ <u>12.75</u>
8. 84" CABLE 3-SEC. ASTRO-BRKT STANDARD ASSEMBLY PELCO P/N SP-1006-FL-46-84	\$ <u>101.⁰⁰</u>
9. 84" ASTRO-BRAC. STELLAR W/ SS-CABLE PELCO P/N SP-1004-FL-84 AS	\$ <u>60.⁰⁰</u>
10. 120" SS-CABLE FOR ASTRO-BRAC PELCO P/N AB-0320-120	\$ <u>26.⁰⁰</u>
11. 5 SECTION ASTRO-BRKT. CLUSTER ARM KIT W/ SS-HARDWARE PELCO P/N AB-5005-SS	\$ <u>110.⁰⁰</u>
12. DOUBLE SERRATED LOCK RING PELCO P/N SE-0451	\$ <u>1.90</u>
13. 5 SECTION ASTRO B. CLUSTER ASSEMBLY PELCO P/N SP-1008-FL-37-84-SS	\$ <u>190.⁰⁰</u>
14. ASTRO-B. STD. CLAMP KIT PELCO P/N SP-1004-FL-84-SS	\$ <u>60.⁰⁰</u>
15. ASTRO-B. FREE SWING ASSEMBLY PELCO P/N AB-3014-84-SS	\$ <u>84.50</u>
16. ASTRO-B. TRI-STUD CLEVIS ADAPTER PELCO P/N SE-4031-ALO-SP	\$ <u>11.⁰⁰</u>
17. HARDWARE KIT, 5-SEC. CLUSTER-SS PELCO P/N AB-0322-SS	\$ <u>18.⁰⁰</u>
18. 5/8" STAINLESS STEEL CLEVIS PIN PELCO P/N FS-6000-SS	\$ <u>1.⁰⁰</u>
19. STELLAR SERIES CLAMP KIT - ASTRO BRACKET PELCO P/N AS-3004-42-ALO	\$ <u>48.⁰⁰</u>
20. CLAMP SCREW KIT W/ HARDWARE PELCO P/N AB-0328-SS	\$ <u>4.25</u>

<u>DESCRIPTION & PART NUMBER</u>	<u>UNIT COST</u>
21. U-BOLT KIT, 5/16-18-SS PELCO P/N AB-0256-SS	\$ <u>1.40</u>
22. TRI-STUD HARDWARE (W/ WASHER & NUTS-SS) PELCO P/N SE-5048-SS	\$ <u>6.80</u>
23. TRI-STUD HARDWARE (W/ BOLTS-SS) PELCO P/N SE-3117-SS	\$ <u>7.70</u>
24. ASTRO-B. STANDARD ARM KIT 9" PELCO P/N AB-4000-SS	\$ <u>26.⁰⁰</u>
25. ASTRO-B. ARM KIT 3M 14" PELCO P/N AB-5000-SS	\$ <u>49.⁰⁰</u>
26. ASTRO-B. TWO WAY UPPER ARM PELCO P/N AB-0296-SS	\$ <u>51.⁰⁰</u>
27. ASTRO-B. TWO WAY LOWER ARM PELCO P/N AB-0297-SS	\$ <u>57.⁰⁰</u>
28. ASTRO-B. UPPER CLUSTER ARM (5 SECTION) PELCO P/N AB-0298-SS	\$ <u>54.⁰⁰</u>
29. ASTRO-B. GUSSETED TUBE KIT PELCO P/N AB-2003-46	\$ <u>19.⁰⁰</u>
30. ASTRO-B. GUSSETED TUBE KIT PELCO P/N AB-2003-58	\$ <u>23.⁰⁰</u>
31. ASTRO-B. TUBE CAP PELCO P/N AB-0260-P02	\$ <u>0.80</u>
32. TWO WAY SIGNAL BRACKET (TOP) PELCO P/N SP-1026-FL-SS-PXX	\$ <u>42.50</u>
33. TWO WAY SIGNAL BRACKET (BOTTOM) PELCO P/N SP-1027-FL-SS	\$ <u>19.50</u>
34. THREE WAY SIGNAL BRACKET (TOP) PELCO P/N SP-1015-FL-SS	\$ <u>65.⁰⁰</u>
35. THREE WAY SIGNAL BRACKET (BOTTOM) PELCO P/N SP-1016-FL-SS	\$ <u>33.⁰⁰</u>
36. FOUR WAY SIGNAL BRACKET (TOP) PELCO P/N SP-1017-FL-SS	\$ <u>74.⁰⁰</u>

FORMAL QUOTE NO.: Q-070204

<u>DESCRIPTION & PART NUMBER</u>	<u>UNIT COST</u>
37. FOUR WAY SIGNAL BRACKET (BOTTOM) PELCO P/N SP-1018-FL-SS	\$ <u>35.⁰⁰</u>
38. ASTRO-BRAC, TENON MNT, SIGN BRK. PELCO P/N AB-3010	\$ <u>55.⁰⁰</u>
39. ASTRO-B. SIGN BRKT. 24" PELCO P/N AB-0283-24-SS	\$ <u>17.⁴⁵</u>
40. ASTRO-B. SIGN BRKT. 30" PELCO P/N AB-0283-30-SS	\$ <u>19.⁷⁵</u>
41. SCHOOL FLASHER CAB. MOUNTING KIT ON 4" PIPE PELCO P/N SE-1100	\$ <u>21.⁰⁰</u>
42. ASTRO MINI SIGN BRACKET W/ 45" CABLE PELCO P/N SP-1072-FL	\$ <u>178.⁰⁰</u>
43. 3/8" X 4" SIGN CLAMP U-BOLT PELCO P/N SH-0209-SS	\$ <u>14.⁰⁰</u>
44. ASTRO-B. SIGN CLAMP W/ HARDWARE PELCO P/N AB-0287-04-SS	\$ <u>9.⁰⁰</u>
45. ASTRO-B. SIGN BRKT. 36" PELCO P/N AB-0283-36-SS	\$ <u>22.⁰⁰</u>
46. ASTRO-B. SIGN BRKT. 72" PELCO P/N AB-0283-72-SS	\$ <u>35.⁰⁰</u>
47. SPAN WIRE SIGN BRKT. CLAMP ASSEMBLY PELCO P/N SE-0321	\$ <u>20.⁰⁰</u>
48. 20" SINGLE SPAN DIAGONAL SIGN BRKT PELCO P/N SP-2028-FL	\$ <u>75.⁰⁰</u>
49. 20" DOUBLE SPAN DIA. SIGN BRKT. ASSY. PELCO P/N: NOT KNOWN - PLEASE SPECIFY P/N OF ITEM QUOTED: <u>SP-2028-FL-SP Double Sign</u>	\$ <u>99.⁰⁰</u>
50. 6" TETHER CLAMP PELCO P/N: NOT KNOWN - PLEASE SPECIFY P/N OF ITEM QUOTED: <u>SP-2043-FL</u>	\$ <u>8.⁸⁰</u>
51. 7/8" OCTAGONAL CAP (SIGNAL CAP) PELCO P/N SE-0361	\$ <u>2.⁶⁵</u>
52. 1-3/8" OCTAGONAL CAP (PED. CAP) PELCO P/N SE-0483	\$ <u>4.³⁵</u>

Revised: 1/12/06

FORMAL QUOTE NO.: Q-070204

<u>DESCRIPTION & PART NUMBER</u>	<u>UNIT COST</u>
53. 5/16"-18 SINGLE STUD HARDWARE KIT PELCO P/N SE-5124-SS	\$ <u>2.⁰⁰</u>
54. PED. HEAD BRKT. PLATE (CURVED) PELCO P/N SE-0357	\$ <u>7.40</u>
55. PED. HEAD BRKT. PLATE (FLAT) PELCO P/N SE-0415	\$ <u>7.40</u>
56. PEDESTRIAN HEAD BRACKET NIPPLE 10-1/2" PELCO P/N SE-0436-10-BOX	\$ <u>6.30</u>
57. PEDESTRIAN HEAD BRACKET 90 DEGREE ELBOWS PELCO P/N SE-0514-SS-BOX	\$ <u>13.20</u>
58. PED. PUSH BUTTON ASSEMBLY (POLE) PELCO P/N SE-2005-08-M1	\$ <u>32.⁰⁰</u>
59. FLAT BRACKET FOR PED. BUTTON PELCO P/N SE-0279-M1	\$ <u>4.30</u>
60. PED. PUSH BUTTON SWITCH PELCO P/N SE-211-PNC	\$ <u>9.⁰⁰</u>
61. PED. SQUARE BASE W/ PLASTIC DOOR PELCO P/N SP-5326-PXX	\$ <u>95.⁰⁰</u>
62. PLASTIC DOOR FOR PED. BASE PELCO P/N PB-0543-PNC	\$ <u>9.⁰⁰</u>
63. POLE CAP, DOME TYPE PELCO P/N PB-5402	\$ <u>7.30</u>
64. COLLAR ASSY. FOR SQ. BASE ALUM. PELCO P/N PB-5325	\$ <u>40.⁰⁰</u>
65. SIDE-OF-POLE ASSY., TRI-STUD PELCO P/N SP-1078-FL	\$ <u>29.⁰⁰</u>
66. TRI-STUD SLIP FITTER PELCO P/N SP-1034-FL	\$ <u>34.30</u>
67. ADJUSTABLE CANTILEVER ARM PELCO P/N SP-1001-FL	\$ <u>610.⁰⁰</u>
68. TRI-STUD ADAPTER PELCO P/N SE-0503	\$ <u>4.70</u>

Revised: 1/12/06

GRAND TOTAL UNIT COST FOR ITEMS 1 THRU 68:

\$ 2,981.90 ✓

WILL YOU DELIVER WITH YOUR OWN VEHICLES AS OPPOSED TO COMMON CARRIER?

YES _____ NO X

TO BE DELIVERED WITHIN 30 CALENDAR DAYS AFTER RECEIPT OF AWARD AND PURCHASE ORDER.

Is your firm interested in being considered for the Local Vendor Preference?

Yes _____ No X

If yes, then read the paragraph entitled "Local Vendor Preference" included in these specifications. Also complete the Local Vendor Preference Questionnaire and return with your quotation.

Quoters should carefully read all the terms and conditions of the specifications. Any representation of deviation or modification to the quote may be grounds to reject the quote.

Are there any modifications to the quote or specifications:

Yes _____ No X

Failure to clearly identify any modifications in the space below or on a separate page may be grounds for the quoter being declared nonresponsive or to have the award of the quote rescinded by the County.

MODIFICATIONS:

Quoter shall submit his/her quote on the County's Proposal Quote Form, including the firm name and authorized signature. Any blank spaces on the Proposal Quote Form, qualifying notes or exceptions, counter offers, lack of required submittals, or signatures, on County's Form may result in the Quoter/Quote being declared non-responsive by the County.

FORMAL QUOTE NO.: Q-070204

ANTI-COLLUSION STATEMENT

THE BELOW SIGNED QUOTER HAS NOT DIVULGED TO, DISCUSSED OR COMPARED HIS QUOTE WITH OTHER QUOTERS AND HAS NOT COLLUDED WITH ANY OTHER QUOTER OR PARTIES TO A QUOTE WHATSOEVER. NOTE: NO PREMIUMS, REBATES OR GRATUITIES TO ANY EMPLOYEE OR AGENT ARE PERMITTED EITHER WITH PRIOR TO OR AFTER ANY DELIVERY OF MATERIALS. ANY SUCH VIOLATION WILL RESULT IN THE CANCELLATION AND/OR RETURN OF MATERIAL (AS APPLICABLE) AND THE REMOVAL FROM THE MASTER BIDDERS LIST.

FIRM NAME TRAFFIC PRODUCTS INC.
BY (Printed): LEN DENIER
BY (Signature): Len Denier
TITLE: President
FEDERAL ID # OR S.S.# 63 0849751
ADDRESS: PO Box 31101
Palm Beach Gardens FL 33420
PHONE NO.: 561 694 0021
FAX NO.: 561 630 5152
CELLULAR PHONE/PAGER NO.: 561 308 2067

LEE COUNTY OCCUPATIONAL LICENSE NUMBER: N/A
E-MAIL ADDRESS: LEN@TRAFFICPRODUCTS.COM
REVISED: 7/28/00

FORMAL QUOTE NO.: Q-070204

agencies and vendor in writing of the effective date of any increase, which is approved. However, the Vendor shall fill all purchase orders received prior to the effective date of the price adjustment at the old contract prices. The Vendor is further advised that price decreases that affect the cost of materials, labor, and transportation are required to be passed on to the County immediately. Failure to do so will result in action to recoup such amounts.

ABIDMENT CERTIFICATE OF NON-DISQUALIFICATION

The amount of the bid is \$ [redacted] and is required and should be submitted with the bid. The amount of the bid is required and should be submitted with the bid. The amount of the bid is required and should be submitted with the bid. The amount of the bid is required and should be submitted with the bid. Failure to do so will result in action to recoup such amounts.

LOCAL BIDDER'S PREFERENCE

Note: In order for your firm to be considered for the local vendor preference, you must complete and return the attached "Local Vendor Preference Questionnaire" with your quotation.

The Lee County Local Bidder's Preference Ordinance No. 00-10 is being included as part of the award process for this project. As such, Lee County at its sole discretion, may choose to award a preference to any qualified "Local Contractor/Vendor" in an amount not to exceed 3 % of the total amount quoted by that firm.

"Local Contractor / Vendor" shall mean: a) any person, firm, partnership, company or corporation whose principal place of business in the sole opinion of the County, is located within the boundaries of Lee County, Florida; or b) any person, firm, partnership, company or corporation that has provided goods or services to Lee County on a regular basis for the preceding consecutive five (5) years, and that has the personnel, equipment and materials located within the boundaries of Lee County sufficient to constitute a present ability to perform the service or provide the goods.

The County reserves the exclusive right to compare, contrast and otherwise evaluate the qualifications, character, responsibility and fitness of all persons, firms, partnerships, companies or corporations submitting formal bids or formal quotes in any procurement for goods or services when making an award in the best interests of the County.

ATTACHMENT A
LOCAL VENDOR PREFERENCE QUESTIONNAIRE
(LEE COUNTY ORDINANCE NO. 00-10)

Instructions: Please complete either Part A or B whichever is applicable to your firm

PART A: VENDOR'S PRINCIPAL PLACE OF BUSINESS IS LOCATED WITHIN LEE COUNTY (Only complete Part A if your principal place of business is located within the boundaries of Lee County)

1. What is the physical location of your principal place of business that is located within the boundaries of Lee County, Florida?

2. What is the size of this facility (i.e. sales area size, warehouse, storage yard, etc.)

PART B: VENDOR'S PRINCIPAL PLACE OF BUSINESS IS NOT LOCATED WITHIN LEE COUNTY OR DOES NOT HAVE A PHYSICAL LOCATION WITHIN LEE COUNTY (Please complete this section.)

1. How many employees are available to service this contract? 1

2. Describe the types and amount of equipment you have available to service this contract.

PC PHONE FAX
All products will be shipped directly from
Pelco's plant in Oklahoma

LOCAL VENDOR PREFERENCE QUESTIONNAIRE CONTINUED

3. Describe the types and amount of material stock that you have available to service this contract.

PELCO IN OKLAHOMA

4. Have you provided goods or services to Lee County on a regular basis for the preceding, consecutive five years?

Yes No

If yes, please provide your contractual history with Lee County for the past five, consecutive years. Attach additional pages if necessary.

HAVE DONE BUSINESS WITH LEE COUNTY
DOT SINCE 1979.

FORMAL QUOTE NO.: Q-070204

AFFIDAVIT CERTIFICATION
IMMIGRATION LAWS

SOLICITATION NO.: Q 070204 PROJECT NAME: Annual Purchase of Pelco Products

LEE COUNTY WILL NOT INTENTIONALLY AWARD COUNTY CONTRACTS TO ANY CONTRACTOR WHO KNOWINGLY EMPLOYS UNAUTHORIZED ALIEN WORKERS, CONSTITUTING A VIOLATION OF THE EMPLOYMENT PROVISIONS CONTAINED IN 8 U.S.C. SECTION 1324 a(e) (SECTION 274A(e) OF THE IMMIGRATION AND NATIONALITY ACT ("INA").

LEE COUNTY MAY CONSIDER THE EMPLOYMENT BY ANY CONTRACTOR OF UNAUTHORIZED ALIENS A VIOLATION OF SECTION 274A(e) OF THE INA. SUCH VIOLATION BY THE RECIPIENT OF THE EMPLOYMENT PROVISIONS CONTAINED IN SECTION 274A(e) OF THE INA SHALL BE GROUNDS FOR UNILATERAL CANCELLATION OF THE CONTRACT BY LEE COUNTY.

BIDDER ATTESTS THAT THEY ARE FULLY COMPLIANT WITH ALL APPLICABLE IMMIGRATION LAWS (SPECIFICALLY TO THE 1986 IMMIGRATION ACT AND SUBSEQUENT AMENDMENTS).

Company Name: Traffic Products Inc.
Jim Conner President 1/22/07
Signature Title Date

STATE OF FL
COUNTY OF Palm Beach

The foregoing instrument was signed and acknowledged before me this 22nd day of Jan 2007, by Leonard John Denier who has produced

FL Driver License D550-520-48-1040 as identification.
(Type of Identification and Number)

Hailey Ruff
Notary Public Signature

Hailey Ruff
Printed Name of Notary Public



DD566847 EX 06/21/2010
Notary Commission Number/Expiration

The signer of this Affidavit guarantees, as evidenced by the sworn affidavit required herein, the truth and accuracy of this affidavit to interrogatories hereinafter made. **LEE COUNTY RESERVES THE RIGHT TO REQUEST SUPPORTING DOCUMENTATION, AS EVIDENCE OF SERVICES PROVIDED, AT ANY TIME.**



www.pelcoinc.com
 320 W. 18TH ST, EDWING OK 75013
 TEL: 405-340-3434 FAX: 405-340-3435

This drawing is for reference only. It is the property of Pelco and is not to be used in whole or in part without Pelco's permission.

ASSEMBLY SHEET

REF: LEE COUNTY,
FLORIDA

TITLE: STABILIZER BAR ASSY
W/ 3/8" HARDWARE

PELCO NO.: SP-2043-FL

Item #50

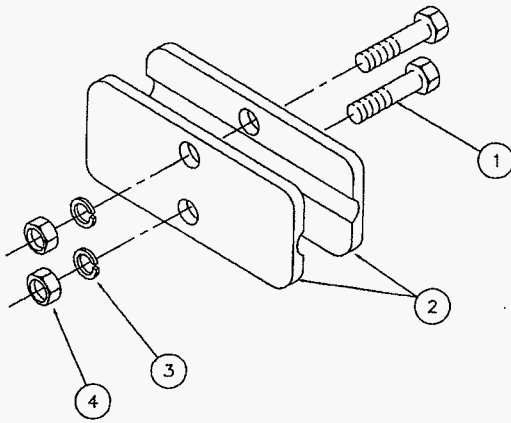

ITEM	PART NO.	DESCRIPTION	QTY
1	FS-2017-SS	BOLT, HEX HD 3/8"-16 X 2" STAINLESS STEEL	2
2	SE-0536-M2	STABILIZER BAR, 2" X 6", 2-HOLE, 3/8 HDWR, ALUM	2
3	FS-4205-SS	WASHER, LOCK SPLIT 3/8", STAINLESS	2
4	FS-1003-SS	NUT, HEX 3/8"-16, STAINLESS	2

INSURANCE REQUIREMENTS

NOTE: Your certificate of insurance must meet the following requirements:

Requirement #1:

The Lee County Board of County Commissioners shall be added as an additional insured on the comprehensive general liability policy.

Requirement #2:

Certificate holder shall be listed as follows:

Lee County Board of County Commissioners
C/O Lee County Purchasing
P.O. Box 398
Fort Myers, FL 33902-0398

Requirement #3:

Each policy shall provide a 30-day notification clause in the event of cancellation, non-renewal or adverse change.

1. **Minimum Insurance Requirements:** *Risk Management in no way represents that the insurance required is sufficient or adequate to protect the vendor's interest or liabilities, but are merely minimums.*
 - a. **Workers' Compensation** - Statutory benefits as defined by FS 440 encompassing all operations contemplated by this contract or agreement to apply to all owners, officers, and employees regardless of the number of employees. Individual employees may be exempted per State Law. Employers' liability will have minimum limits of:
 - \$500,000 per accident
 - \$500,000 disease limit
 - \$500,000 disease limit per employee
 - b. **Commercial General Liability** - Coverage shall apply to premises and/or operations, products and/or completed operations, independent contractors, contractual liability, and exposures with minimum limits of:

Revised: 1/12/06

26

subcontractors comply with all insurance requirements.

Revised: 1/12/06

27

01/18/97 13:35 FAX 4053400524

PELCO PRODUCTS

0001

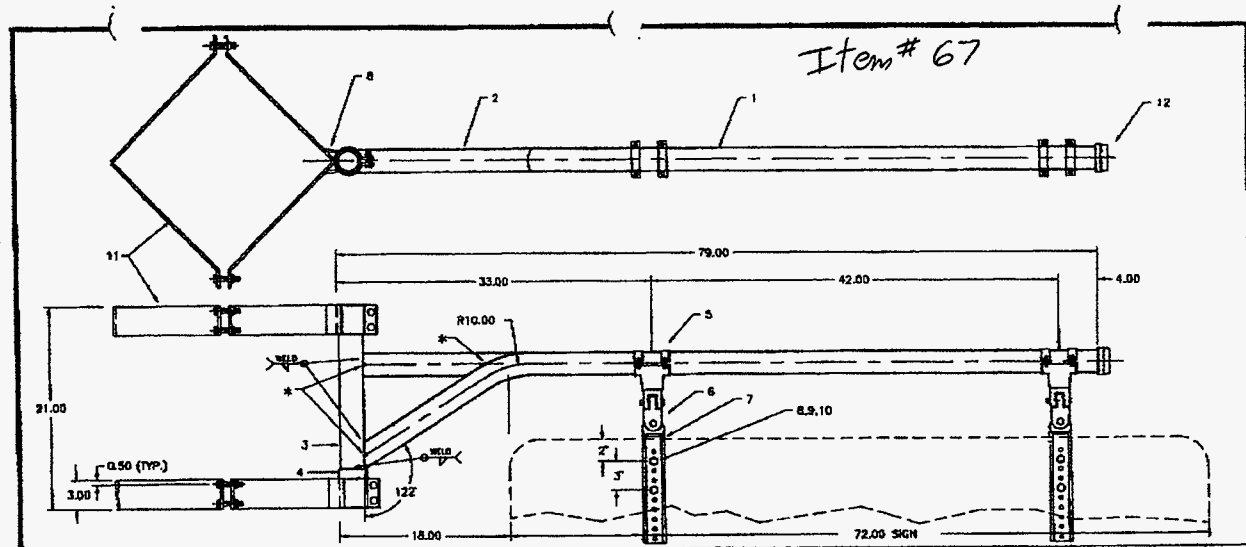

NOTES:
 * VENT HOLE FOR GALVANIZING
 MATERIAL: STEEL
 FINISH: GALV
 FOR CLAMP & HARDWARE SEE #SP-5189.

Material	Coating	Code
Aluminum	A	
Black Phosphate	BP	
Chromate	C	
Hot Dipping	HD	
Galvanized Steel	GS	
Zinc	Z	
Zinc Yellow	ZY	
Elect. Steel	ES	
Painted	P	

ITEM	PART NO.	DESCRIPTION	CMT	QTY.
12	AP-0150	POLE CAP, 2 3/8"	P	2
11	SP-5189	ADJ. CLAMP FOR SQUARE POLE, 14 1/2"-16 1/2" W/HENRL	G	2
10	FS-1001-SS	NUT, HEX, 5/16"-18	SS	4
9	FS-4201-SS	LOCKWASHER, SPLIT, 5/16"	SS	4
8	FS-2006-SS	BOLT, HEX HD., 5/16"-18 x 1"	SS	4
7	SE-0539	EXTENDER CONNECTOR HANGER, 10-HOLE	A	2
6	SE-0467	CLEVIS HANGER, 3/4" x 3/4" W/ PINS	A	2
5	AB-0118	ASTRO-BRAC CLAMP KIT, TENNON MNT, 1.9"-4.5" O.D.	A	2
4	FB-S202-D1	2 1/2" SCH 40 (2 7/8" O.D.) STEEL COLLAR x 1"	G	1
3	SE-4084-21	2" SCH 40 (2 3/8" O.D.) STEEL PIPE x 21"	G	1
2	SE-4084-18	2" SCH 40 (2 3/8" O.D.) STEEL PIPE x 18"	R	1
1	SE-4084-75.75	2" SCH 40 (2 3/8" O.D.) STEEL PIPE x 75 3/4"	G	1

pelco
 PELCO PRODUCTS, INC.

320 S. W. 18TH
 EDMOND, OKLAHOMA 73013
 (405) 340-3434 FAX (405) 340-3435

DRAWN: LORRIE ACORD DATE: 10/18/93 CHECKED: DATE: SCALE: NTS REV: 4/18/94 P/H: SP-1001-FL

ADJUSTABLE CANTILEVER ARM (14 1/2"-16 1/2" SQUARE POLE)
 STATE OF FLORIDA
 TITLE:

LEE COUNTY PURCHASING - BIDDERS CHECK LIST

IMPORTANT: Please read carefully and return with your bid proposal.
Please check off each of the following items as the necessary action is completed:

- 1. The Quote has been signed.
- 2. The Quote prices offered have been reviewed.
- 3. The price extensions and totals have been checked.
- 4. The original (must be manually signed) and 2 copies of the quote have been submitted.
- 5. Three (3) identical sets of descriptive literature, brochures and/or data (if required) have been submitted under separate cover.
- 6. All modifications have been acknowledged in the space provided.
- 7. All addendums issued, if any, have been acknowledged in the space provided.
- 8. Erasures or other changes made to the quote document have been initialed by the person signing the quote.
- 9. Bid Bond and/or certified Check, (if required) have been submitted with the quote in amounts indicated.
- 10. Any Delivery information required is included.
- 11. Affidavit Certification Immigration Signed and Notarized
- 12. The mailing envelope has been addressed to:

MAILING ADDRESS Lee County Purchasing P.O. Box 398 or Ft. Myers, FL 33902-0398	PHYSICAL ADDRESS Lee County Purchasing 1825 Hendry St 3 rd Floor Ft. Myers, FL 33901
---	---
- 13. The mailing envelope **MUST** be sealed and marked with:
Quote Number _____
Opening Date and/or Receiving Date _____
- 14. The quote will be mailed or delivered in time to be received no later than the specified opening date and time. (Otherwise quote cannot be considered or accepted.)
- 15. If submitting a "NO BID" please write quote number here _____ and check one of the following:
 - Do not offer this product Insufficient time to respond.
 - Unable to meet specifications (why)
 - Unable to meet bond or insurance requirement.
 - Other: _____

Company Name and Address:
Traffic Products Inc.
P.O. Box 3119
1906, FL 33420

Cheves, Judith E.

From: ljd_9 [ljd_9@prodigy.net]
Sent: Thursday, March 08, 2007 4:12 PM
To: Cheves, Judith E.
Subject: Pelco Bid Q-070204
Attachments: 40DDD_31_107396.pdf

Hi Judy,

Attached is our certificate of insurance to Lee County.

Thank You,

Len Denien

TRAFFIC PRODUCTS, INC.
PO Box 31101
Palm Beach Garden, FL 33420
Phone: 561-694-0021
Fax: 561-630-5152
len@trafficproducts.com
www.trafficproducts.com

3/8/2007

ACORD™ CERTIFICATE OF LIABILITY INSURANCE

DATE (MM/DD/YYYY)
03/08/07

PRODUCER Compass Insurance Agency Sevier, Fowlkes & Jackson 728 Shades Creek Pkwy, #200 Birmingham, AL 35209	THIS CERTIFICATE IS ISSUED AS A MATTER OF INFORMATION ONLY AND CONFERS NO RIGHTS UPON THE CERTIFICATE HOLDER. THIS CERTIFICATE DOES NOT AMEND, EXTEND OR ALTER THE COVERAGE AFFORDED BY THE POLICIES BELOW.	
	INSURED Traffic Products, Inc. Tammy Coggins P.O. Box 361017 Birmingham, AL 35236	INSURERS AFFORDING COVERAGE
	INSURER A: EMC Insurance Companies	
	INSURER B: Bridgefield Employers Insurance Comp	
	INSURER C:	
	INSURER D:	
	INSURER E:	

COVERAGES

THE POLICIES OF INSURANCE LISTED BELOW HAVE BEEN ISSUED TO THE INSURED NAMED ABOVE FOR THE POLICY PERIOD INDICATED. NOTWITHSTANDING ANY REQUIREMENT, TERM OR CONDITION OF ANY CONTRACT OR OTHER DOCUMENT WITH RESPECT TO WHICH THIS CERTIFICATE MAY BE ISSUED OR MAY PERTAIN, THE INSURANCE AFFORDED BY THE POLICIES DESCRIBED HEREIN IS SUBJECT TO ALL THE TERMS, EXCLUSIONS AND CONDITIONS OF SUCH POLICIES. AGGREGATE LIMITS SHOWN MAY HAVE BEEN REDUCED BY PAID CLAIMS.

INSR ADD'L LTR	INSRD	TYPE OF INSURANCE	POLICY NUMBER	POLICY EFFECTIVE DATE (MM/DD/YY)	POLICY EXPIRATION DATE (MM/DD/YY)	LIMITS	
A		GENERAL LIABILITY <input checked="" type="checkbox"/> COMMERCIAL GENERAL LIABILITY <input type="checkbox"/> CLAIMS MADE <input checked="" type="checkbox"/> OCCUR _____ _____ GEN'L AGGREGATE LIMIT APPLIES PER: <input checked="" type="checkbox"/> POLICY <input type="checkbox"/> PRO-JECT <input type="checkbox"/> LOC	3X2991706	10/01/06	10/01/07	EACH OCCURRENCE	\$300,000
						DAMAGE TO RENTED PREMISES (Ea occurrence)	\$100,000
						MED EXP (Any one person)	\$5,000
						PERSONAL & ADV INJURY	\$300,000
						GENERAL AGGREGATE	\$300,000
						PRODUCTS - COMP/OP AGG	\$300,000
		AUTOMOBILE LIABILITY <input type="checkbox"/> ANY AUTO <input type="checkbox"/> ALL OWNED AUTOS <input type="checkbox"/> SCHEDULED AUTOS <input type="checkbox"/> HIRED AUTOS <input type="checkbox"/> NON-OWNED AUTOS				COMBINED SINGLE LIMIT (Ea accident)	\$
						BODILY INJURY (Per person)	\$
						BODILY INJURY (Per accident)	\$
						PROPERTY DAMAGE (Per accident)	\$
		GARAGE LIABILITY <input type="checkbox"/> ANY AUTO				AUTO ONLY - EA ACCIDENT	\$
						OTHER THAN AUTO ONLY: EA ACC	\$
						AGG	\$
		EXCESS/UMBRELLA LIABILITY <input type="checkbox"/> OCCUR <input type="checkbox"/> CLAIMS MADE _____ _____ DEDUCTIBLE RETENTION \$				EACH OCCURRENCE	\$
						AGGREGATE	\$
							\$
							\$
B		WORKERS COMPENSATION AND EMPLOYERS' LIABILITY ANY PROPRIETOR/PARTNER/EXECUTIVE OFFICER/MEMBER EXCLUDED? If yes, describe under SPECIAL PROVISIONS below	19603789 FL WC ONLY	09/27/06	09/27/07	<input checked="" type="checkbox"/> WC STATU-TORY LIMITS <input type="checkbox"/> OTH-ER	
						E.L. EACH ACCIDENT	\$100,000
						E.L. DISEASE - EA EMPLOYEE	\$100,000
						E.L. DISEASE - POLICY LIMIT	\$500,000
		OTHER					

DESCRIPTION OF OPERATIONS / LOCATIONS / VEHICLES / EXCLUSIONS ADDED BY ENDORSEMENT / SPECIAL PROVISIONS

Certificate Holder is named as Additional Insured on General Liability.

CERTIFICATE HOLDER

Lee County Board of County Commissioners
 c/o Lee County
 Purchasing
 P. O. Box 398
 Fort Myers, FL 33902-0398

CANCELLATION

SHOULD ANY OF THE ABOVE DESCRIBED POLICIES BE CANCELLED BEFORE THE EXPIRATION DATE THEREOF, THE ISSUING INSURER WILL ENDEAVOR TO MAIL 30 DAYS WRITTEN NOTICE TO THE CERTIFICATE HOLDER NAMED TO THE LEFT, BUT FAILURE TO DO SO SHALL IMPOSE NO OBLIGATION OR LIABILITY OF ANY KIND UPON THE INSURER, ITS AGENTS OR REPRESENTATIVES.

AUTHORIZED REPRESENTATIVE
Patton Bradford

IMPORTANT

If the certificate holder is an **ADDITIONAL INSURED**, the policy(ies) must be endorsed. A statement on this certificate does not confer rights to the certificate holder in lieu of such endorsement(s).

If **SUBROGATION IS WAIVED**, subject to the terms and conditions of the policy, certain policies may require an endorsement. A statement on this certificate does not confer rights to the certificate holder in lieu of such endorsement(s).

DISCLAIMER

The Certificate of Insurance on the reverse side of this form does not constitute a contract between the issuing insurer(s), authorized representative or producer, and the certificate holder, nor does it affirmatively or negatively amend, extend or alter the coverage afforded by the policies listed thereon.

ACORD™ CERTIFICATE OF LIABILITY INSURANCE

DATE (MM/DD/YYYY)
03/08/07

PRODUCER Compass Insurance Agency Sevier, Fowlkes & Jackson 728 Shades Creek Pkwy, #200 Birmingham, AL 35209	THIS CERTIFICATE IS ISSUED AS A MATTER OF INFORMATION ONLY AND CONFERS NO RIGHTS UPON THE CERTIFICATE HOLDER. THIS CERTIFICATE DOES NOT AMEND, EXTEND OR ALTER THE COVERAGE AFFORDED BY THE POLICIES BELOW.	
	INSURED Traffic Products, Inc. Tammy Coggins P.O. Box 361017 Birmingham, AL 35236	INSURERS AFFORDING COVERAGE INSURER A: EMC Insurance Companies INSURER B: Bridgefield Employers Insurance Comp INSURER C: INSURER D: INSURER E:

COVERAGES

THE POLICIES OF INSURANCE LISTED BELOW HAVE BEEN ISSUED TO THE INSURED NAMED ABOVE FOR THE POLICY PERIOD INDICATED. NOTWITHSTANDING ANY REQUIREMENT, TERM OR CONDITION OF ANY CONTRACT OR OTHER DOCUMENT WITH RESPECT TO WHICH THIS CERTIFICATE MAY BE ISSUED OR MAY PERTAIN, THE INSURANCE AFFORDED BY THE POLICIES DESCRIBED HEREIN IS SUBJECT TO ALL THE TERMS, EXCLUSIONS AND CONDITIONS OF SUCH POLICIES. AGGREGATE LIMITS SHOWN MAY HAVE BEEN REDUCED BY PAID CLAIMS.

INSR ADD'L LTR	INSRD	TYPE OF INSURANCE	POLICY NUMBER	POLICY EFFECTIVE DATE (MM/DD/YY)	POLICY EXPIRATION DATE (MM/DD/YY)	LIMITS
A		GENERAL LIABILITY <input checked="" type="checkbox"/> COMMERCIAL GENERAL LIABILITY <input type="checkbox"/> CLAIMS MADE <input checked="" type="checkbox"/> OCCUR GEN'L AGGREGATE LIMIT APPLIES PER: <input checked="" type="checkbox"/> POLICY <input type="checkbox"/> PRO-JECT <input type="checkbox"/> LOC	3X2991706	10/01/06	10/01/07	EACH OCCURRENCE \$300,000 DAMAGE TO RENTED PREMISES (Ea occurrence) \$100,000 MED EXP (Any one person) \$5,000 PERSONAL & ADV INJURY \$300,000 GENERAL AGGREGATE \$300,000 PRODUCTS - COMP/OP AGG \$300,000
		AUTOMOBILE LIABILITY <input type="checkbox"/> ANY AUTO <input type="checkbox"/> ALL OWNED AUTOS <input type="checkbox"/> SCHEDULED AUTOS <input type="checkbox"/> HIRED AUTOS <input type="checkbox"/> NON-OWNED AUTOS				COMBINED SINGLE LIMIT (Ea accident) \$ BODILY INJURY (Per person) \$ BODILY INJURY (Per accident) \$ PROPERTY DAMAGE (Per accident) \$
		GARAGE LIABILITY <input type="checkbox"/> ANY AUTO				AUTO ONLY - EA ACCIDENT \$ OTHER THAN AUTO ONLY: EA ACC \$ AGG \$
		EXCESS/UMBRELLA LIABILITY <input type="checkbox"/> OCCUR <input type="checkbox"/> CLAIMS MADE <input type="checkbox"/> DEDUCTIBLE RETENTION \$				EACH OCCURRENCE \$ AGGREGATE \$ \$ \$
B		WORKERS COMPENSATION AND EMPLOYERS' LIABILITY ANY PROPRIETOR/PARTNER/EXECUTIVE OFFICER/MEMBER EXCLUDED? If yes, describe under SPECIAL PROVISIONS below	19603789 FL WC ONLY	09/27/06	09/27/07	<input checked="" type="checkbox"/> WC STATU-TORY LIMITS <input type="checkbox"/> OTH-ER E.L. EACH ACCIDENT \$100,000 E.L. DISEASE - EA EMPLOYEE \$100,000 E.L. DISEASE - POLICY LIMIT \$500,000
		OTHER				

DESCRIPTION OF OPERATIONS / LOCATIONS / VEHICLES / EXCLUSIONS ADDED BY ENDORSEMENT / SPECIAL PROVISIONS

Certificate Holder is named as Additional Insured on General Liability.

CERTIFICATE HOLDER Lee County Board of County Commissioners c/o Lee County Purchasing P. O. Box 398 Fort Myers, FL 33902-0398	CANCELLATION SHOULD ANY OF THE ABOVE DESCRIBED POLICIES BE CANCELLED BEFORE THE EXPIRATION DATE THEREOF, THE ISSUING INSURER WILL ENDEAVOR TO MAIL <u>30</u> DAYS WRITTEN NOTICE TO THE CERTIFICATE HOLDER NAMED TO THE LEFT, BUT FAILURE TO DO SO SHALL IMPOSE NO OBLIGATION OR LIABILITY OF ANY KIND UPON THE INSURER, ITS AGENTS OR REPRESENTATIVES. AUTHORIZED REPRESENTATIVE <i>Patten Bradford</i>
---	--

IMPORTANT

If the certificate holder is an **ADDITIONAL INSURED**, the policy(ies) must be endorsed. A statement on this certificate does not confer rights to the certificate holder in lieu of such endorsement(s).

If **SUBROGATION IS WAIVED**, subject to the terms and conditions of the policy, certain policies may require an endorsement. A statement on this certificate does not confer rights to the certificate holder in lieu of such endorsement(s).

DISCLAIMER

The Certificate of Insurance on the reverse side of this form does not constitute a contract between the issuing insurer(s), authorized representative or producer, and the certificate holder, nor does it affirmatively or negatively amend, extend or alter the coverage afforded by the policies listed thereon.

ATTACHMENT #3

FORMAL QUOTE NO.: Q-070204

LEE COUNTY, FLORIDA
PROPOSAL QUOTE FORM
FOR THE ANNUAL PURCHASE OF PELCO PRODUCTS

DATE SUBMITTED: 22 JAN 2007

VENDOR NAME: TEMPLE INC

TO: The Board of County Commissioners
Lee County
Fort Myers, Florida

Having carefully examined the "General Conditions", and the "Detailed Specifications", all of which are contained herein, the Undersigned proposes to furnish the following which meet these specifications:

The undersigned acknowledges receipt of Addenda numbers:

GRAND TOTAL UNIT COST FOR ITEMS 1 THRU 68:

\$ 2228.00

SPECIFY PRICES FOR ITEMS AS LISTED BELOW. ALL ITEMS SHALL BE NEW, UNUSED, GENUINE PELCO AS SPECIFIED - NO SUBSTITUTES, EQUALS, OR REMANUFACTURED/RECONDITIONED PRODUCTS ARE ACCEPTABLE.

<u>DESCRIPTION & PART NUMBER</u>	<u>UNIT COST</u>
1. 12 CIRCUIT DISCONNECT PELCO P/N SP-1021-FL-BOX	\$ <u>131.00</u>
2. WING SCREW W/ KEEPER PELCO P/N SE-0407-SS	\$ <u>2.00</u>
3. HUB (PELCO) (SHORT) PELCO P/N SE-0504	\$ <u>9.00</u>
4. ADJUSTABLE HANGER ASSEMBLY W/ TETHER PELCO P/N SP-2027-FL	\$ <u>38.00</u>

<u>DESCRIPTION & PART NUMBER</u>	<u>UNIT COST</u>
5. EXTENDER BAR (6 FT.) PELCO P/N SE-0507-72-ALO	\$ <u>19.00</u>
6. TRI-STUD BALANCER ASSEMBLY (3/4" WIDE) PELCO P/N SE-5034	\$ <u>15.00</u>
7. SINGLE EYE BALANCER (PIPE) PELCO P/N SE-4030	\$ <u>14.00</u>
8. 84" CABLE 3-SEC. ASTRO-BRKT STANDARD ASSEMBLY PELCO P/N SP-1006-FL-46-84	\$ <u>113.00</u>
9. 84" ASTRO-BRAC. STELLAR W/ SS-CABLE PELCO P/N SP-1004-FL-84	\$ <u>48.00</u>
10. 120" SS-CABLE FOR ASTRO-BRAC PELCO P/N AB-0320-120	\$ <u>29.00</u>
11. 5 SECTION ASTRO-BRKT. CLUSTER ARM KIT W/ SS-HARDWARE PELCO P/N AB-5005-SS	\$ <u>112.00</u>
12. DOUBLE SERRATED LOCK RING PELCO P/N SE-0451	\$ <u>3.00</u>
13. 5 SECTION ASTRO B. CLUSTER ASSEMBLY PELCO P/N SP-1008-FL-37-84-SS	\$ <u>211.00</u>
14. ASTRO-B. STD. CLAMP KIT PELCO P/N SP-1004-FL-84-SS	\$ <u>47.00</u>
15. ASTRO-B. FREE SWING ASSEMBLY PELCO P/N AB-3014-84-SS	\$ <u>69.00</u>
16. ASTRO-B. TRI-STUD CLEVIS ADAPTER PELCO P/N SE-4031-ALO-SP	\$ <u>12.00</u>
17. HARDWARE KIT, 5-SEC. CLUSTER-SS PELCO P/N AB-0322-SS	\$ <u>19.00</u>
18. 5/8" STAINLESS STEEL CLEVIS PIN PELCO P/N FS-6000-SS	\$ <u>NO BID</u>
19. STELLAR SERIES CLAMP KIT - ASTRO BRACKET PELCO P/N AS-3004-42-ALO	\$ <u>51.00</u>
20. CLAMP SCREW KIT W/ HARDWARE PELCO P/N AB-0328-SS	\$ <u>13.00</u>

<u>DESCRIPTION & PART NUMBER</u>	<u>UNIT COST</u>
21. U-BOLT KIT, 5/16-18-SS PELCO P/N AB-0256-SS	\$ <u>2.00</u>
22. TRI-STUD HARDWARE (W/ WASHER & NUTS-SS) PELCO P/N SE-5048-SS	\$ <u>3.00</u>
23. TRI-STUD HARDWARE (W/ BOLTS-SS) PELCO P/N SE-3117-SS	\$ <u>5.00</u>
24. ASTRO-B. STANDARD ARM KIT 9" PELCO P/N AB-4000-SS	\$ <u>21.00</u>
25. ASTRO-B. ARM KIT 3M 14" PELCO P/N AB-5000-SS	\$ <u>52.00</u>
26. ASTRO-B. TWO WAY UPPER ARM PELCO P/N AB-0296-SS	\$ <u>48.00</u>
27. ASTRO-B. TWO WAY LOWER ARM PELCO P/N AB-0297-SS	\$ <u>55.00</u>
28. ASTRO-B. UPPER CLUSTER ARM (5 SECTION) PELCO P/N AB-0298-SS	\$ <u>51.00</u>
29. ASTRO-B. GUSSETED TUBE KIT PELCO P/N AB-2003-46	\$ <u>20.00</u>
30. ASTRO-B. GUSSETED TUBE KIT PELCO P/N AB-2003-58	\$ <u>25.00</u>
31. ASTRO-B. TUBE CAP PELCO P/N AB-0260-P02	\$ <u>2.00</u>
32. TWO WAY SIGNAL BRACKET (TOP) PELCO P/N SP-1026-FL-SS-PXX	\$ <u>47.00</u>
33. TWO WAY SIGNAL BRACKET (BOTTOM) PELCO P/N SP-1027-FL-SS	\$ <u>22.00</u>
34. THREE WAY SIGNAL BRACKET (TOP) PELCO P/N SP-1015-FL-SS	\$ <u>75.00</u>
35. THREE WAY SIGNAL BRACKET (BOTTOM) PELCO P/N SP-1016-FL-SS	\$ <u>37.00</u>
36. FOUR WAY SIGNAL BRACKET (TOP) PELCO P/N SP-1017-FL-SS	\$ <u>82.00</u>

<u>DESCRIPTION & PART NUMBER</u>	<u>UNIT COST</u>
37. FOUR WAY SIGNAL BRACKET (BOTTOM) PELCO P/N SP-1018-FL-SS	\$ <u>39.00</u>
38. ASTRO-BRAC, TENON MNT, SIGN BRK. PELCO P/N AB-3010	\$ <u>56.00</u>
39. ASTRO-B. SIGN BRKT. 24" PELCO P/N AB-0283-24-SS	\$ <u>19.00</u>
40. ASTRO-B. SIGN BRKT. 30" PELCO P/N AB-0283-30-SS	\$ <u>21.00</u>
41. SCHOOL FLASHER CAB. MOUNTING KIT ON 4" PIPE PELCO P/N SE-1100	\$ <u>23.00</u>
42. ASTRO MINI SIGN BRACKET W/ 45" CABLE PELCO P/N SP-1072-FL	\$ <u>193.00</u>
43. 3/8" X 4" SIGN CLAMP U-BOLT PELCO P/N SP-0209-SS <i>BID SH-0206</i> <i>OBSOLETE</i>	\$ <u>15.00</u>
44. ASTRO-B. SIGN CLAMP W/ HARDWARE PELCO P/N AB-0287-04-SS <i>BID AB-0502 4"</i> <i>OBSOLETE</i>	\$ <u>10.00</u>
45. ASTRO-B. SIGN BRKT. 36" PELCO P/N AB-0283-36-SS	\$ <u>23.00</u>
46. ASTRO-B. SIGN BRKT. 72" PELCO P/N AB-0283-72-SS	\$ <u>38.00</u>
47. SPAN WIRE SIGN BRKT. CLAMP ASSEMBLY PELCO P/N SE-0321	\$ <u>14.00</u>
48. 20" SINGLE SPAN DIAGONAL SIGN BRKT PELCO P/N SP-2028-FL	\$ <u>No Bid</u>
49. 20" DOUBLE SPAN DIA. SIGN BRKT. ASSY. PELCO P/N: NOT KNOWN - PLEASE SPECIFY P/N OF ITEM QUOTED: _____	\$ <u>No Bid</u>
50. 6" TETHER CLAMP PELCO P/N: NOT KNOWN - PLEASE SPECIFY P/N OF ITEM QUOTED: _____	\$ <u>No Bid</u>
51. 7/8" OCTAGONAL CAP (SIGNAL CAP) PELCO P/N SE-0361	\$ <u>4.00</u>
52. 1-3/8" OCTAGONAL CAP (PED. CAP) PELCO P/N SE-0483	\$ <u>5.00</u>

<u>DESCRIPTION & PART NUMBER</u>	<u>UNIT COST</u>
53. 5/16"-18 SINGLE STUD HARDWARE KIT PELCO P/N SE-5124-SS OBSOLETE BID SE-5064-SS	\$ <u>3.00</u>
54. PED. HEAD BRKT. PLATE (CURVED) PELCO P/N SE-0357	\$ <u>9.00</u>
55. PED. HEAD BRKT. PLATE (FLAT) PELCO P/N SE-0415	\$ <u>8.00</u>
56. PEDESTRIAN HEAD BRACKET NIPPLE 10-1/2" PELCO P/N SE-0436-10-BOX	\$ <u>7.00</u>
57. PEDESTRIAN HEAD BRACKET 90 DEGREE ELBOWS PELCO P/N SE-0514-SS-BOX	\$ <u>14.00</u>
58. PED. PUSH BUTTON ASSEMBLY (POLE) PELCO P/N SE-2005-08-M1	\$ <u>32.00</u>
59. FLAT BRACKET FOR PED. BUTTON PELCO P/N SE-0279-M1	\$ <u>5.00</u>
60. PED. PUSH BUTTON SWITCH PELCO P/N SE-211-PNC	\$ <u>No Bid</u>
61. PED. SQUARE BASE W/ PLASTIC DOOR PELCO P/N SP-5326-PXX	\$ <u>No Bid</u>
62. PLASTIC DOOR FOR PED. BASE PELCO P/N PB-0543-PNC	\$ <u>10.00</u>
63. POLE CAP, DOME TYPE PELCO P/N PB-5402	\$ <u>8.00</u>
64. COLLAR ASSY. FOR SQ. BASE ALUM. PELCO P/N PB-5325	\$ <u>45.00</u>
65. SIDE-OF-POLE ASSY., TRI-STUD PELCO P/N SP-1078-FL	\$ <u>41.00</u>
66. TRI-STUD SLIP FITTER PELCO P/N SP-1034-FL	\$ <u>38.00</u>
67. ADJUSTABLE CANTILEVER ARM PELCO P/N SP-1001-FL	\$ <u>No Bid</u>
68. TRI-STUD ADAPTER PELCO P/N SE-0503 OBSOLETE BID SE-0502	\$ <u>6.00</u>

GRAND TOTAL UNIT COST FOR ITEMS 1 THRU 68:

✓ \$ 2228.00

WILL YOU DELIVER WITH YOUR OWN VEHICLES AS OPPOSED TO COMMON CARRIER?

YES _____ NO

TO BE DELIVERED WITHIN 40 CALENDAR DAYS AFTER RECEIPT OF AWARD AND PURCHASE ORDER.

Is your firm interested in being considered for the Local Vendor Preference?

Yes _____ No

If yes, then read the paragraph entitled "Local Vendor Preference" included in these specifications. Also complete the Local Vendor Preference Questionnaire and return with your quotation.

Quoters should carefully read all the terms and conditions of the specifications. Any representation of deviation or modification to the quote may be grounds to reject the quote.

Are there any modifications to the quote or specifications:

Yes No _____

Failure to clearly identify any modifications in the space below or on a separate page may be grounds for the quoter being declared nonresponsive or to have the award of the quote rescinded by the County.

MODIFICATIONS:

NO BID ITEMS # 18, # 48, # 49, # 50, # 60, # 61, # 67

REPLACE OBSOLETE PART NUMBERS ON BID ITEMS # 43, # 44, # 53, # 68

Quoter shall submit his/her quote on the County's Proposal Quote Form, including the firm name and authorized signature. Any blank spaces on the Proposal Quote Form, qualifying notes or exceptions, counter offers, lack of required submittals, or signatures, on County's Form may result in the Quoter/Quote being declared non-responsive by the County.

ANTI-COLLUSION STATEMENT

THE BELOW SIGNED QUOTER HAS NOT DIVULGED TO, DISCUSSED OR COMPARED HIS QUOTE WITH OTHER QUOTERS AND HAS NOT COLLUDED WITH ANY OTHER QUOTER OR PARTIES TO A QUOTE WHATSOEVER. NOTE: NO PREMIUMS, REBATES OR GRATUITIES TO ANY EMPLOYEE OR AGENT ARE PERMITTED EITHER WITH, PRIOR TO, OR AFTER ANY DELIVERY OF MATERIALS. ANY SUCH VIOLATION WILL RESULT IN THE CANCELLATION AND/OR RETURN OF MATERIAL (AS APPLICABLE) AND THE REMOVAL FROM THE MASTER BIDDERS LIST.

FIRM NAME TEMPLE INC.
BY (Printed): KEITH FRASIER
BY (Signature): Keith A. Frasier
TITLE: FL SALES SUPPORT
FEDERAL ID # OR S.S.# 630573758
ADDRESS: PO BOX 2066
DECATUR, AL 35602
PHONE NO.: 256-353-3820
FAX NO.: 256-353-4578
CELLULAR PHONE/PAGER NO.: 407-701-4649

LEE COUNTY OCCUPATIONAL LICENSE NUMBER: N/A
E-MAIL ADDRESS: keith.frasier@temple-inc.com

REVISED: 7/28/00

2007 FEB 26 PM 12:44

AFFIDAVIT CERTIFICATION
IMMIGRATION LAWS

204 PROJECT NAME: ANNUAL PURCHASE OF PELCO PRODUCT

INTENTIONALLY AWARD COUNTY CONTRACTS TO ANY CONTRACTOR WHO WILL DIRECTLY OR INDIRECTLY EMPLOY UNAUTHORIZED ALIEN WORKERS, IN VIOLATION OF THE EMPLOYMENT PROVISIONS CONTAINED IN 8 U.S.C. SECTION 274A(e) OF THE IMMIGRATION AND NATIONALITY ACT

WHICH IS A VIOLATION OF SECTION 274A(e) OF THE INA. SUCH A VIOLATION OF THE EMPLOYMENT PROVISIONS CONTAINED IN SECTION 274A(e) SHALL BE GROUNDS FOR UNILATERAL CANCELLATION OF THE CONTRACT BY THE COUNTY.

THEY ARE FULLY COMPLIANT WITH ALL APPLICABLE LAWS RELATING TO THE 1986 IMMIGRATION ACT AND SUBSEQUENT AMENDMENTS.

TEMPLE INC

Keith A. Frasier, FLSALES SUPPORT 22 Jan 2007
Signature Title Date

STATE OF Alabama
COUNTY OF Morgan

The foregoing instrument was signed and acknowledged before me this 22 day of January, 2007, by Keith Frasier who has produced (Print or Type Name)

_____ as identification.
(Type of Identification and Number)

Christine Hall
Notary Public Signature

Christine Hall
Printed Name of Notary Public

My Commission Expires 1-18-2010
Notary Commission Number/Expiration

raised seal

The signee of this Affidavit guarantees, as evidenced by the sworn affidavit required herein, the truth and accuracy of this affidavit to interrogatories hereinafter made. LEE COUNTY RESERVES THE RIGHT TO REQUEST SUPPORTING DOCUMENTATION, AS EVIDENCE OF SERVICES PROVIDED, AT ANY TIME.

FORMAL QUOTE NO.: Q 070204

AFFIDAVIT CERTIFICATION
IMMIGRATION LAWS

SOLICITATION NO.: Q-070204 PROJECT NAME: ANNUAL PURCHASE OF PECO PRODUCT

LEE COUNTY WILL NOT INTENTIONALLY AWARD COUNTY CONTRACTS TO ANY CONTRACTOR WHO KNOWINGLY EMPLOYS UNAUTHORIZED ALIEN WORKERS, CONSTITUTING A VIOLATION OF THE EMPLOYMENT PROVISIONS CONTAINED IN 8 U.S.C. SECTION 1324 a(e) (SECTION 274A(e) OF THE IMMIGRATION AND NATIONALITY ACT ("INA").

LEE COUNTY MAY CONSIDER THE EMPLOYMENT BY ANY CONTRACTOR OF UNAUTHORIZED ALIENS A VIOLATION OF SECTION 274A(e) OF THE INA. SUCH VIOLATION BY THE RECIPIENT OF THE EMPLOYMENT PROVISIONS CONTAINED IN SECTION 274A(e) OF THE INA SHALL BE GROUNDS FOR UNILATERAL CANCELLATION OF THE CONTRACT BY LEE COUNTY.

BIDDER ATTESTS THAT THEY ARE FULLY COMPLIANT WITH ALL APPLICABLE IMMIGRATION LAWS (SPECIFICALLY TO THE 1986 IMMIGRATION ACT AND SUBSEQUENT AMENDMENTS).

Company Name: TEMPLE INC
Signature: Keith A. Frasier Title: FLSALES SUPPORT Date: 22 Jan 2007

STATE OF Alabama
COUNTY OF Morgan

The foregoing instrument was signed and acknowledged before me this 22 day of January, 2007, by Keith Frasier who has produced
(Print or Type Name)

_____ as identification.
(Type of Identification and Number)

Christine Hall
Notary Public Signature

Christine Hall
Printed Name of Notary Public

Notary Commission Expires 1-18-2010
Notary Commission Number/Expiration

The signer of this Affidavit guarantees, as evidenced by the sworn affidavit required herein, the truth and accuracy of this affidavit to interrogatories hereinafter made. LEE COUNTY RESERVES THE RIGHT TO REQUEST SUPPORTING DOCUMENTATION, AS EVIDENCE OF SERVICES PROVIDED, AT ANY TIME.

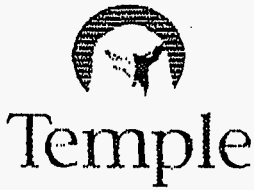

Mailing
Keith Frasier
TEMPLE, INC.
P.O. Box 2066
Decatur, AL 35601

PH: 256.353.3820
Fax: 256.353.4578

Shipping

Temple, Inc.
50 Davis St.
Decatur, AL 35602

Facsimile transmittal

To: Judy Fax: 239-344-5460
From: Keith Frasier Date: 23 February 2007
Re: Notarized affidavit Pages: 2 including cover
CC:

Urgent For Review Please Comment Please Reply Please Recycle

Judy,

Here is the photocopy of the notarized affidavit. The copy is of poor quality, so please accept it today and I am also mailing the hard copy with the actual notary stamp on my copy of the original document.

Thank you,

Keith

AFFIDAVIT CERTIFICATION
IMMIGRATION LAWS

SOLICITATION NO.: Q-070204 PROJECT NAME: ANNUAL PURCHASE OF PELCO PRODUCT

LEE COUNTY WILL NOT INTENTIONALLY AWARD COUNTY CONTRACTS TO ANY CONTRACTOR WHO KNOWINGLY EMPLOYS UNAUTHORIZED ALIEN WORKERS, CONSTITUTING A VIOLATION OF THE EMPLOYMENT PROVISIONS CONTAINED IN 8 U.S.C. SECTION 1324 a(e) {SECTION 274A(e) OF THE IMMIGRATION AND NATIONALITY ACT ("INA").

LEE COUNTY MAY CONSIDER THE EMPLOYMENT BY ANY CONTRACTOR OF UNAUTHORIZED ALIENS A VIOLATION OF SECTION 274A(e) OF THE INA. SUCH VIOLATION BY THE RECIPIENT OF THE EMPLOYMENT PROVISIONS CONTAINED IN SECTION 274A(e) OF THE INA SHALL BE GROUNDS FOR UNILATERAL CANCELLATION OF THE CONTRACT BY LEE COUNTY.

BIDDER ATTESTS THAT THEY ARE FULLY COMPLIANT WITH ALL APPLICABLE IMMIGRATION LAWS (SPECIFICALLY TO THE 1986 IMMIGRATION ACT AND SUBSEQUENT AMENDMENTS).

Company Name: TEMPLE INC
Keith A. Frasier, FLSALES SUPPORT 22 Jan 2007
Signature Title Date

STATE OF Alabama
COUNTY OF Morgan

The foregoing instrument was signed and acknowledged before me this 22 day of January, 2007, by Keith Frasier who has produced
(Print or Type Name)

_____ as identification.
(Type of Identification and Number)

Christine Hall
Notary Public Signature

Christine Hall
Printed Name of Notary Public

My Commission Expires 1-18-2010
Notary Commission Number/Expiration

The signee of this Affidavit guarantees, as evidenced by the sworn affidavit required herein, the truth and accuracy of this affidavit to interrogatories hereinafter made. LEE COUNTY RESERVES THE RIGHT TO REQUEST SUPPORTING DOCUMENTATION, AS EVIDENCE OF SERVICES PROVIDED, AT ANY TIME.

ACORD™ CERTIFICATE OF LIABILITY INSURANCE

DATE (MM/DD/YYYY)
01/22/2007

PRODUCER (256)353-7931 FAX (256)350-5318
 ANB Insurance Services, Inc.
 P. O. Drawer F
 Decatur, AL 35602
 Carrie Williams

THIS CERTIFICATE IS ISSUED AS A MATTER OF INFORMATION ONLY AND CONFERS NO RIGHTS UPON THE CERTIFICATE HOLDER. THIS CERTIFICATE DOES NOT AMEND, EXTEND OR ALTER THE COVERAGE AFFORDED BY THE POLICIES BELOW.

INSURED Temple, Inc.
 Po Box 2066
 Decatur, AL 35602

INSURERS AFFORDING COVERAGE		NAIC #
INSURER A:	Travelers Insurance Group	
INSURER B:	Alabama Self-Insured W/C Fund	
INSURER C:		
INSURER D:		
INSURER E:		

COVERAGES

THE POLICIES OF INSURANCE LISTED BELOW HAVE BEEN ISSUED TO THE INSURED NAMED ABOVE FOR THE POLICY PERIOD INDICATED. NOTWITHSTANDING ANY REQUIREMENT, TERM OR CONDITION OF ANY CONTRACT OR OTHER DOCUMENT WITH RESPECT TO WHICH THIS CERTIFICATE MAY BE ISSUED OR MAY PERTAIN, THE INSURANCE AFFORDED BY THE POLICIES DESCRIBED HEREIN IS SUBJECT TO ALL THE TERMS, EXCLUSIONS AND CONDITIONS OF SUCH POLICIES. AGGREGATE LIMITS SHOWN MAY HAVE BEEN REDUCED BY PAID CLAIMS.

INSR LTR	ADD'L INSRD	TYPE OF INSURANCE	POLICY NUMBER	POLICY EFFECTIVE DATE (MM/DD/YY)	POLICY EXPIRATION DATE (MM/DD/YY)	LIMITS	
		GENERAL LIABILITY <input checked="" type="checkbox"/> COMMERCIAL GENERAL LIABILITY <input type="checkbox"/> CLAIMS MADE <input checked="" type="checkbox"/> OCCUR GEN'L AGGREGATE LIMIT APPLIES PER: <input checked="" type="checkbox"/> POLICY <input type="checkbox"/> PRO-JECT <input type="checkbox"/> LOC	Y63099K9226	04/01/2006	04/01/2007	EACH OCCURRENCE	\$ 1,000,000
						DAMAGE TO RENTED PREMISES (Ea occurrence)	\$ 100,000
						MED EXP (Any one person)	\$ 5,000
						PERSONAL & ADV INJURY	\$ 1,000,000
						GENERAL AGGREGATE	\$ 2,000,000
						PRODUCTS - COMP/OP AGG	\$ 2,000,000
		AUTOMOBILE LIABILITY <input checked="" type="checkbox"/> ANY AUTO <input type="checkbox"/> ALL OWNED AUTOS <input type="checkbox"/> SCHEDULED AUTOS <input checked="" type="checkbox"/> HIRED AUTOS <input checked="" type="checkbox"/> NON-OWNED AUTOS <input checked="" type="checkbox"/> Comp. Ded. \$500 <input checked="" type="checkbox"/> Coll. Ded. \$1,000	Y81099K9226	04/01/2006	04/01/2007	COMBINED SINGLE LIMIT (Ea accident)	\$ 1,000,000
						BODILY INJURY (Per person)	\$
						BODILY INJURY (Per accident)	\$
						PROPERTY DAMAGE (Per accident)	\$
		GARAGE LIABILITY <input type="checkbox"/> ANY AUTO				AUTO ONLY - EA ACCIDENT	\$
						OTHER THAN AUTO ONLY: EA ACC	\$
						AGG	\$
		EXCESS/UMBRELLA LIABILITY <input checked="" type="checkbox"/> OCCUR <input type="checkbox"/> CLAIMS MADE <input type="checkbox"/> DEDUCTIBLE <input type="checkbox"/> RETENTION \$	CUP 99K9226	04/01/2006	04/01/2007	EACH OCCURRENCE	\$ 1,000,000
						AGGREGATE	\$ 1,000,000
							\$
							\$
		WORKERS COMPENSATION AND EMPLOYERS' LIABILITY ANY PROPRIETOR/PARTNER/EXECUTIVE OFFICER/MEMBER EXCLUDED? If yes, describe under SPECIAL PROVISIONS below OTHER	3110	01/01/2007	01/01/2008	<input checked="" type="checkbox"/> WC STATUTORY LIMITS <input type="checkbox"/> OTHER	
						E.L. EACH ACCIDENT	\$ 1,000,000
						E.L. DISEASE - EA EMPLOYEE	\$ 1,000,000
						E.L. DISEASE - POLICY LIMIT	\$ 1,000,000

DESCRIPTION OF OPERATIONS / LOCATIONS / VEHICLES / EXCLUSIONS ADDED BY ENDORSEMENT / SPECIAL PROVISIONS
 Lee County, a political subdivision and Charter County of the state of Florida, its agents, employees, and public officials will be named as Additional Insured on the General Liability policy.

CERTIFICATE HOLDER

CANCELLATION

Lee County Board of County Commissioners
 C/O Lee County Purchasing
 P.O. Box 398
 Fort Myers, FL 33902-0398

SHOULD ANY OF THE ABOVE DESCRIBED POLICIES BE CANCELLED BEFORE THE EXPIRATION DATE THEREOF, THE ISSUING INSURER WILL ENDEAVOR TO MAIL 30 DAYS WRITTEN NOTICE TO THE CERTIFICATE HOLDER NAMED TO THE LEFT, BUT FAILURE TO MAIL SUCH NOTICE SHALL IMPOSE NO OBLIGATION OR LIABILITY OF ANY KIND UPON THE INSURER, ITS AGENTS OR REPRESENTATIVES.
 AUTHORIZED REPRESENTATIVE: *John T. Tolson*

IMPORTANT

If the certificate holder is an ADDITIONAL INSURED, the policy(ies) must be endorsed. A statement on this certificate does not confer rights to the certificate holder in lieu of such endorsement(s).

If SUBROGATION IS WAIVED; subject to the terms and conditions of the policy, certain policies may require an endorsement. A statement on this certificate does not confer rights to the certificate holder in lieu of such endorsement(s).

DISCLAIMER

The Certificate of Insurance on the reverse side of this form does not constitute a contract between the issuing insurer(s), authorized representative or producer, and the certificate holder, nor does it affirmatively or negatively amend, extend or alter the coverage afforded by the policies listed thereon.

**LEE COUNTY, FLORIDA
PROPOSAL QUOTE FORM
FOR THE ANNUAL PURCHASE OF PELCO PRODUCTS**

DATE SUBMITTED: January 19, 2007

VENDOR NAME: Transportation Control Systems, Inc.

TO: The Board of County Commissioners
Lee County
Fort Myers, Florida

Having carefully examined the "General Conditions", and the "Detailed Specifications", all of which are contained herein, the Undersigned proposes to furnish the following which meet these specifications:

The undersigned acknowledges receipt of Addenda numbers:

GRAND TOTAL UNIT COST FOR ITEMS 1 THRU 68:

✓ \$ 2882.00

SPECIFY PRICES FOR ITEMS AS LISTED BELOW. ALL ITEMS SHALL BE NEW, UNUSED, GENUINE PELCO AS SPECIFIED – NO SUBSTITUTES, EQUALS, OR REMANUFACTURED/RECONDITIONED PRODUCTS ARE ACCEPTABLE.

<u>DESCRIPTION & PART NUMBER</u>	<u>UNIT COST</u>
1. 12 CIRCUIT DISCONNECT PELCO P/N SP-1021-FL-BOX	\$ <u>114.00</u>
2. WING SCREW W/ KEEPER PELCO P/N SE-0407-SS	\$ <u>2.00</u>
3. HUB (PELCO) (SHORT) PELCO P/N SE-0504	\$ <u>8.00</u>
4. ADJUSTABLE HANGER ASSEMBLY W/ TETHER PELCO P/N SP-2027-FL	\$ <u>33.00</u>

<u>DESCRIPTION & PART NUMBER</u>	<u>UNIT COST</u>
5. EXTENDER BAR (6 FT.) PELCO P/N SE-0507-72-ALO	\$ <u>18.00</u>
6. TRI-STUD BALANCER ASSEMBLY (3/4" WIDE) PELCO P/N SE-5034	\$ <u>18.00</u>
7. SINGLE EYE BALANCER (PIPE) PELCO P/N SE-4030	\$ <u>12.00</u>
8. 84" CABLE 3-SEC. ASTRO-BRKT STANDARD ASSEMBLY PELCO P/N SP-1006-FL-46-84	\$ <u>98.00</u>
9. 84" ASTRO-BRAC. STELLAR W/ SS-CABLE PELCO P/N SP-1004-FL-84	\$ <u>59.00</u>
10. 120" SS-CABLE FOR ASTRO-BRAC PELCO P/N AB-0320-120	\$ <u>28.00</u>
11. 5 SECTION ASTRO-BRKT. CLUSTER ARM KIT W/ SS-HARDWARE PELCO P/N AB-5005-SS	\$ <u>111.00</u>
12. DOUBLE SERRATED LOCK RING PELCO P/N SE-0451	\$ <u>2.00</u>
13. 5 SECTION ASTRO B. CLUSTER ASSEMBLY PELCO P/N SP-1008-FL-37-84-SS	\$ <u>186.00</u>
14. ASTRO-B. STD. CLAMP KIT PELCO P/N SP-1004-FL-84-SS	\$ <u>58.00</u>
15. ASTRO-B. FREE SWING ASSEMBLY PELCO P/N AB-3014-84-SS	\$ <u>80.00</u>
16. ASTRO-B. TRI-STUD CLEVIS ADAPTER PELCO P/N SE-4031-ALO-SP	\$ <u>10.00</u>
17. HARDWARE KIT, 5-SEC. CLUSTER-SS PELCO P/N AB-0322-SS	\$ <u>18.00</u>
18. 5/8" STAINLESS STEEL CLEVIS PIN PELCO P/N FS-6000-SS	\$ <u>1.00</u>
19. STELLAR SERIES CLAMP KIT - ASTRO BRACKET PELCO P/N AS-3004-42-ALO	\$ <u>49.00</u>
20. CLAMP SCREW KIT W/ HARDWARE PELCO P/N AB-0328-SS	\$ <u>4.00</u>

<u>DESCRIPTION & PART NUMBER</u>	<u>UNIT COST</u>
21. U-BOLT KIT, 5/16-18-SS PELCO P/N AB-0256-SS	\$ 2.00
22. TRI-STUD HARDWARE (W/ WASHER & NUTS-SS) PELCO P/N SE-5048-SS	\$ 7.00
23. TRI-STUD HARDWARE (W/ BOLTS-SS) PELCO P/N SE-3117-SS	\$ 8.00
24. ASTRO-B. STANDARD ARM KIT 9" PELCO P/N AB-4000-SS	\$ 26.00
25. ASTRO-B. ARM KIT 3M 14" PELCO P/N AB-5000-SS	\$ 49.00
26. ASTRO-B. TWO WAY UPPER ARM PELCO P/N AB-0296-SS	\$ 52.00
27. ASTRO-B. TWO WAY LOWER ARM PELCO P/N AB-0297-SS	\$ 57.00
28. ASTRO-B. UPPER CLUSTER ARM (5 SECTION) PELCO P/N AB-0298-SS	\$ 54.00
29. ASTRO-B. GUSSETED TUBE KIT PELCO P/N AB-2003-46	\$ 19.00
30. ASTRO-B. GUSSETED TUBE KIT PELCO P/N AB-2003-58	\$ 24.00
31. ASTRO-B. TUBE CAP PELCO P/N AB-0260-P02	\$ 1.00
32. TWO WAY SIGNAL BRACKET (TOP) PELCO P/N SP-1026-FL-SS-PXX	\$ 40.00
33. TWO WAY SIGNAL BRACKET (BOTTOM) PELCO P/N SP-1027-FL-SS	\$ 19.00
34. THREE WAY SIGNAL BRACKET (TOP) PELCO P/N SP-1015-FL-SS	\$ 64.00
35. THREE WAY SIGNAL BRACKET (BOTTOM) PELCO P/N SP-1016-FL-SS	\$ 32.00
36. FOUR WAY SIGNAL BRACKET (TOP) PELCO P/N SP-1017-FL-SS	\$ 71.00

<u>DESCRIPTION & PART NUMBER</u>	<u>UNIT COST</u>
37. FOUR WAY SIGNAL BRACKET (BOTTOM) PELCO P/N SP-1018-FL-SS	\$ <u>34.00</u>
38. ASTRO-BRAC, TENON MNT, SIGN BRK. PELCO P/N AB-3010	\$ <u>54.00</u>
39. ASTRO-B. SIGN BRKT. 24" PELCO P/N AB-0283-24-SS	\$ <u>18.00</u>
40. ASTRO-B. SIGN BRKT. 30" PELCO P/N AB-0283-30-SS	\$ <u>20.00</u>
41. SCHOOL FLASHER CAB. MOUNTING KIT ON 4" PIPE PELCO P/N SE-1100	\$ <u>23.00</u>
42. ASTRO MINI SIGN BRACKET W/ 45" CABLE PELCO P/N SP-1072-FL	\$ <u>169.00</u>
43. 3/8" X 4" SIGN CLAMP U-BOLT PELCO P/N SH-0209-SS	\$ <u>14.00</u>
44. ASTRO-B. SIGN CLAMP W/ HARDWARE PELCO P/N AB-0287-04-SS	\$ <u>9.00</u>
45. ASTRO-B. SIGN BRKT. 36" PELCO P/N AB-0283-36-SS	\$ <u>22.00</u>
46. ASTRO-B. SIGN BRKT. 72" PELCO P/N AB-0283-72-SS	\$ <u>36.00</u>
47. SPAN WIRE SIGN BRKT. CLAMP ASSEMBLY PELCO P/N SE-0321	\$ <u>18.00</u>
48. 20" SINGLE SPAN DIAGONAL SIGN BRKT PELCO P/N SP-2028-FL	\$ <u>63.00</u>
49. 20" DOUBLE SPAN DIA. SIGN BRKT. ASSY. PELCO P/N: NOT KNOWN - PLEASE SPECIFY P/N OF ITEM QUOTED: <u>SE 5112</u>	\$ <u>95.00</u>
50. 6" TETHER CLAMP PELCO P/N: NOT KNOWN - PLEASE SPECIFY P/N OF ITEM QUOTED: <u>SP-2042-FL</u>	\$ <u>11.00</u>
51. 7/8" OCTAGONAL CAP (SIGNAL CAP) PELCO P/N SE-0361	\$ <u>3.00</u>
52. 1-3/8" OCTAGONAL CAP (PED. CAP) PELCO P/N SE-0483	\$ <u>5.00</u>

<u>DESCRIPTION & PART NUMBER</u>	<u>UNIT COST</u>
53. 5/16"-18 SINGLE STUD HARDWARE KIT PELCO P/N SE-5124-SS	\$ 3.00
54. PED. HEAD BRKT. PLATE (CURVED) PELCO P/N SE-0357	\$ 8.00
55. PED. HEAD BRKT. PLATE (FLAT) PELCO P/N SE-0415	\$ 8.00
56. PEDESTRIAN HEAD BRACKET NIPPLE 10-1/2" PELCO P/N SE-0436-10-BOX	\$ 6.00
57. PEDESTRIAN HEAD BRACKET 90 DEGREE ELBOWS PELCO P/N SE-0514-SS-BOX	\$ 13.00
58. PED. PUSH BUTTON ASSEMBLY (POLE) PELCO P/N SE-2005-08-M1	\$ 15.00
59. FLAT BRACKET FOR PED. BUTTON PELCO P/N SE-0279-M1	\$ 5.00
60. PED. PUSH BUTTON SWITCH PELCO P/N SE-211-PNC	\$ 9.00
61. PED. SQUARE BASE W/ PLASTIC DOOR PELCO P/N SP-5326-PXX	\$ 80.00
62. PLASTIC DOOR FOR PED. BASE PELCO P/N PB-0543-PNC	\$ 9.00
63. POLE CAP, DOME TYPE PELCO P/N PB-5402	\$ 7.00
64. COLLAR ASSY. FOR SQ. BASE ALUM. PELCO P/N PB-5325	\$ 40.00
65. SIDE-OF-POLE ASSY., TRI-STUD PELCO P/N SP-1078-FL	\$ 34.00
66. TRI-STUD SLIP FITTER PELCO P/N SP-1034-FL	\$ 33.00
67. ADJUSTABLE CANTILEVER ARM PELCO P/N SP-1001-FL	\$ 579.00
68. TRI-STUD ADAPTER PELCO P/N SE-0503	\$ 5.00

GRAND TOTAL UNIT COST FOR ITEMS 1 THRU 68:

\$ 2882.00

WILL YOU DELIVER WITH YOUR OWN VEHICLES AS OPPOSED TO COMMON CARRIER?

YES _____ NO X

TO BE DELIVERED WITHIN 30 CALENDAR DAYS AFTER RECEIPT OF AWARD AND PURCHASE ORDER.

Is your firm interested in being considered for the Local Vendor Preference?

Yes X No _____

If yes, then read the paragraph entitled "Local Vendor Preference" included in these specifications. Also complete the Local Vendor Preference Questionnaire and return with your quotation.

Quoters should carefully read all the terms and conditions of the specifications. Any representation of deviation or modification to the quote may be grounds to reject the quote.

Are there any modifications to the quote or specifications:

Yes _____ No X

Failure to clearly identify any modifications in the space below or on a separate page may be grounds for the quoter being declared nonresponsive or to have the award of the quote rescinded by the County.

MODIFICATIONS:

Quoter shall submit his/her quote on the County's Proposal Quote Form, including the firm name and authorized signature. Any blank spaces on the Proposal Quote Form, qualifying notes or exceptions, counter offers, lack of required submittals, or signatures, on County's Form may result in the Quoter/Quote being declared non-responsive by the County.

ANTI-COLLUSION STATEMENT

THE BELOW SIGNED QUOTER HAS NOT DIVULGED TO, DISCUSSED OR COMPARED HIS QUOTE WITH OTHER QUOTERS AND HAS NOT COLLUDED WITH ANY OTHER QUOTER OR PARTIES TO A QUOTE WHATSOEVER. NOTE: NO PREMIUMS, REBATES OR GRATUITIES TO ANY EMPLOYEE OR AGENT ARE PERMITTED EITHER WITH, PRIOR TO, OR AFTER ANY DELIVERY OF MATERIALS. ANY SUCH VIOLATION WILL RESULT IN THE CANCELLATION AND/OR RETURN OF MATERIAL (AS APPLICABLE) AND THE REMOVAL FROM THE MASTER BIDDERS LIST.

FIRM NAME Transportation Control Systems, Inc.

BY (Printed): Jack D. Clemons

BY (Signature):

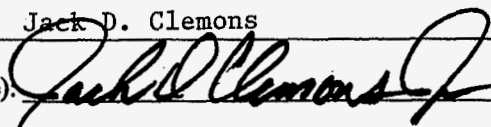

TITLE: Sales Engineer

FEDERAL ID # OR S.S.# 59-1673144

ADDRESS: 1030 South 86th Street

Tampa, Fl 33619

PHONE NO.: 813-630-2800

FAX NO.: 813-630-2801

CELLULAR PHONE/PAGER NO.: _____

LEE COUNTY OCCUPATIONAL LICENSE NUMBER: _____

E-MAIL ADDRESS: dclemons@tcstraffic.com

REVISED: 7/28/00

ATTACHMENT A
LOCAL VENDOR PREFERENCE QUESTIONNAIRE
(LEE COUNTY ORDINANCE NO. 00-10)

Instructions: Please complete either Part A or B whichever is applicable to your firm

PART A: VENDOR'S PRINCIPAL PLACE OF BUSINESS IS LOCATED WITHIN LEE COUNTY (Only complete Part A if your principal place of business is located within the boundaries of Lee County)

1. What is the physical location of your principal place of business that is located within the boundaries of Lee County, Florida?

2. What is the size of this facility (i.e. sales area size, warehouse, storage yard, etc.)

PART B: VENDOR'S PRINCIPAL PLACE OF BUSINESS IS NOT LOCATED WITHIN LEE COUNTY OR DOES NOT HAVE A PHYSICAL LOCATION WITHIN LEE COUNTY (Please complete this section.)

1. How many employees are available to service this contract? _____
6

2. Describe the types and amount of equipment you have available to service this contract.

Transportation Control Systems is an authorized Pelco distributor
for the State of Florida and warehouses \$300,000.00 worth of equipment,
mast arms, span wire and post top pelco hardware.

LOCAL VENDOR PREFERENCE QUESTIONNAIRE CONTINUED

3. Describe the types and amount of material stock that you have available to service this contract.

The warehousing of \$300,000.00 worth of materials for Pelco
such as mast arms, span wire and post top pelco hardware.

4. Have you provided goods or services to Lee County on a regular basis for the preceding, consecutive five years?

Yes X No

If yes, please provide your contractual history with Lee County for the past five, consecutive years. Attach additional pages if necessary.

Annual Contract #Q-050063 12/04 - 12/06
Pelco Hardware

FORMAL QUOTE NO.: Q-070204

AFFIDAVIT CERTIFICATION
IMMIGRATION LAWS

SOLICITATION NO.: Q-070204

PROJECT NAME: Annual Purchase of Pelco Products

LEE COUNTY WILL NOT INTENTIONALLY AWARD COUNTY CONTRACTS TO ANY CONTRACTOR WHO KNOWINGLY EMPLOYS UNAUTHORIZED ALIEN WORKERS, CONSTITUTING A VIOLATION OF THE EMPLOYMENT PROVISIONS CONTAINED IN 8 U.S.C. SECTION 1324 a(e) {SECTION 274A(e) OF THE IMMIGRATION AND NATIONALITY ACT ("INA").

LEE COUNTY MAY CONSIDER THE EMPLOYMENT BY ANY CONTRACTOR OF UNAUTHORIZED ALIENS A VIOLATION OF SECTION 274A(e) OF THE INA. SUCH VIOLATION BY THE RECIPIENT OF THE EMPLOYMENT PROVISIONS CONTAINED IN SECTION 274A(e) OF THE INA SHALL BE GROUNDS FOR UNILATERAL CANCELLATION OF THE CONTRACT BY LEE COUNTY.

BIDDER ATTESTS THAT THEY ARE FULLY COMPLIANT WITH ALL APPLICABLE IMMIGRATION LAWS (SPECIFICALLY TO THE 1986 IMMIGRATION ACT AND SUBSEQUENT AMENDMENTS).

Company Name: Transportation Control Systems, Inc.

[Signature] VP
Signature Title

1-19-07
Date

STATE OF Florida
COUNTY OF Hillsborough

The foregoing instrument was signed and acknowledged before me this 19 day of January, 20 07 by John S. Gillis who has produced

(Print or Type Name)
Known as identification.

(Type of Identification and Number)

[Signature]
Notary Public Signature

Carole H. Robinson

Printed Name of Notary Public

DD207025 0825/07

Notary Commission Number/Expiration



CAROLE H. ROBINSON
MY COMMISSION # DD 207025
EXPIRES: August 25, 2007
Bonded Thru Budget Notary Services

The signee of this Affidavit guarantees, as evidenced by the sworn affidavit required herein, the truth and accuracy of this affidavit to interrogatories hereinafter made. **LEE COUNTY RESERVES THE RIGHT TO REQUEST SUPPORTING DOCUMENTATION, AS EVIDENCE OF SERVICES PROVIDED, AT ANY TIME.**

AFFIDAVIT CERTIFICATION
IMMIGRATION LAWS

SOLICITATION NO.: Q-070204

PROJECT NAME: Annual Purchase of Pelco Products

LEE COUNTY WILL NOT INTENTIONALLY AWARD COUNTY CONTRACTS TO ANY CONTRACTOR WHO KNOWINGLY EMPLOYS UNAUTHORIZED ALIEN WORKERS, CONSTITUTING A VIOLATION OF THE EMPLOYMENT PROVISIONS CONTAINED IN 8 U.S.C. SECTION 1324 a(e) (SECTION 274A(e) OF THE IMMIGRATION AND NATIONALITY ACT ("INA").

LEE COUNTY MAY CONSIDER THE EMPLOYMENT BY ANY CONTRACTOR OF UNAUTHORIZED ALIENS A VIOLATION OF SECTION 274A(e) OF THE INA. SUCH VIOLATION BY THE RECIPIENT OF THE EMPLOYMENT PROVISIONS CONTAINED IN SECTION 274A(e) OF THE INA SHALL BE GROUNDS FOR UNILATERAL CANCELLATION OF THE CONTRACT BY LEE COUNTY.

BIDDER ATTESTS THAT THEY ARE FULLY COMPLIANT WITH ALL APPLICABLE IMMIGRATION LAWS (SPECIFICALLY TO THE 1986 IMMIGRATION ACT AND SUBSEQUENT AMENDMENTS).

Company Name: Transportation Control Systems, Inc.

[Signature] VP
Signature Title

1-19-07
Date

STATE OF Florida
COUNTY OF Hillsborough

The foregoing instrument was signed and acknowledged before me this 19 day of January, 20 07 by John S. Gillis who has produced
(Print or Type Name)
Known _____ as identification.

(Type of Identification and Number)

[Signature]
Notary Public Signature

Carole H. Robinson

Printed Name of Notary Public

DD207025 0825/07

Notary Commission Number/Expiration

The signee of this Affidavit guarantees, as evidenced by the sworn affidavit required herein, the truth and accuracy of this affidavit to interrogatories hereinafter made. **LEE COUNTY RESERVES THE RIGHT TO REQUEST SUPPORTING DOCUMENTATION, AS EVIDENCE OF SERVICES PROVIDED, AT ANY TIME.**

ACORD™ CERTIFICATE OF LIABILITY INSURANCE		DATE (MM/DD/YYYY) 2/28/2007												
PRODUCER (727) 391-9791 FAX: (727) 393-5623 Stahl & Associates Insurance, Inc. 110 Carillon Parkway St. Petersburg FL 33716		THIS CERTIFICATE IS ISSUED AS A MATTER OF INFORMATION ONLY AND CONFERS NO RIGHTS UPON THE CERTIFICATE HOLDER. THIS CERTIFICATE DOES NOT AMEND, EXTEND OR ALTER THE COVERAGE AFFORDED BY THE POLICIES BELOW.												
INSURED Transportation Control Systems Inc 908 Riviera Dunes Way Palmetto FL 34221		<table border="1" style="width:100%; border-collapse: collapse;"> <tr> <th style="text-align: left;">INSURERS AFFORDING COVERAGE</th> <th style="text-align: left;">NAIC #</th> </tr> <tr> <td>INSURER A: Hartford Fire Insurance</td> <td>19682</td> </tr> <tr> <td>INSURER B: Hartford Casualty</td> <td>29424</td> </tr> <tr> <td>INSURER C: Admiral Insurance Company</td> <td></td> </tr> <tr> <td>INSURER D:</td> <td></td> </tr> <tr> <td>INSURER E:</td> <td></td> </tr> </table>	INSURERS AFFORDING COVERAGE	NAIC #	INSURER A: Hartford Fire Insurance	19682	INSURER B: Hartford Casualty	29424	INSURER C: Admiral Insurance Company		INSURER D:		INSURER E:	
INSURERS AFFORDING COVERAGE	NAIC #													
INSURER A: Hartford Fire Insurance	19682													
INSURER B: Hartford Casualty	29424													
INSURER C: Admiral Insurance Company														
INSURER D:														
INSURER E:														

COVERAGES
 THE POLICIES OF INSURANCE LISTED BELOW HAVE BEEN ISSUED TO THE INSURED NAMED ABOVE FOR THE POLICY PERIOD INDICATED, NOTWITHSTANDING ANY REQUIREMENT, TERM OR CONDITION OF ANY CONTRACT OR OTHER DOCUMENT WITH RESPECT TO WHICH THIS CERTIFICATE MAY BE ISSUED OR MAY PERTAIN, THE INSURANCE AFFORDED BY THE POLICIES DESCRIBED HEREIN IS SUBJECT TO ALL THE TERMS, EXCLUSIONS AND CONDITIONS OF SUCH POLICIES. AGGREGATE LIMITS SHOWN MAY HAVE BEEN REDUCED BY PAID CLAIMS.

INSR ADDL LTR INSRD	TYPE OF INSURANCE	POLICY NUMBER	POLICY EFFECTIVE DATE (MM/DD/YY)	POLICY EXPIRATION DATE (MM/DD/YY)	LIMITS
A	GENERAL LIABILITY <input checked="" type="checkbox"/> COMMERCIAL GENERAL LIABILITY <input type="checkbox"/> CLAIMS MADE <input checked="" type="checkbox"/> OCCUR GEN'L AGGREGATE LIMIT APPLIES PER: <input checked="" type="checkbox"/> POLICY <input type="checkbox"/> PRO-JECT <input type="checkbox"/> LOC	2100N009272	1/16/2007	1/16/2008	EACH OCCURRENCE \$ 2,000,000
	DAMAGE TO RENTED PREMISES (Ea occurrence) \$ 300,000 MED EXP (Any one person) \$ 10,000 PERSONAL & ADV INJURY \$ 1,000,000 GENERAL AGGREGATE \$ 1,000,000 PRODUCTS - COMP/OP AGG \$ See Below				
A	AUTOMOBILE LIABILITY <input checked="" type="checkbox"/> ANY AUTO <input type="checkbox"/> ALL OWNED AUTOS <input type="checkbox"/> SCHEDULED AUTOS <input checked="" type="checkbox"/> HIRED AUTOS <input checked="" type="checkbox"/> NON-OWNED AUTOS	2100N009272	1/16/2007	1/16/2008	COMBINED SINGLE LIMIT (Ea accident) \$ 1,000,000
	BODILY INJURY (Per person) \$ BODILY INJURY (Per accident) \$ PROPERTY DAMAGE (Per accident) \$				
	GARAGE LIABILITY <input type="checkbox"/> ANY AUTO				AUTO ONLY - EA ACCIDENT \$ OTHER THAN EA ACC \$ AUTO ONLY: AGG \$
B	EXCESS/UMBRELLA LIABILITY <input checked="" type="checkbox"/> OCCUR <input type="checkbox"/> CLAIMS MADE <input type="checkbox"/> DEDUCTIBLE <input checked="" type="checkbox"/> RETENTION \$ 10,000	21RH0009381	1/16/2007	1/16/2008	EACH OCCURRENCE \$ 5,000,000
	AGGREGATE \$ 5,000,000				
	WORKERS COMPENSATION AND EMPLOYERS' LIABILITY ANY PROPRIETOR/PARTNER/EXECUTIVE OFFICER/MEMBER EXCLUDED? If yes, describe under SPECIAL PROVISIONS below				<input type="checkbox"/> WC STATUTORY LIMITS <input type="checkbox"/> OTHER E.L. EACH ACCIDENT \$ E.L. DISEASE - EA EMPLOYEE \$ E.L. DISEASE - POLICY LIMIT \$
C	OTHER Product Liability	CA000002671	1/16/2007	1/16/2008	Aggregate Limit \$2,000,000 Occurrence Limit \$2,000,000 Deductible \$10,000

DESCRIPTION OF OPERATIONS/LOCATIONS/VEHICLES/EXCLUSIONS ADDED BY ENDORSEMENT/SPECIAL PROVISIONS

CERTIFICATE HOLDER Lee County Board of County Commissioners Lee County Purchasing P O Box 398 Ft Myers, FL 33902-0398	CANCELLATION SHOULD ANY OF THE ABOVE DESCRIBED POLICIES BE CANCELLED BEFORE THE EXPIRATION DATE THEREOF, THE ISSUING INSURER WILL ENDEAVOR TO MAIL <u>10</u> DAYS WRITTEN NOTICE TO THE CERTIFICATE HOLDER NAMED TO THE LEFT, BUT FAILURE TO DO SO SHALL IMPOSE NO OBLIGATION OR LIABILITY OF ANY KIND UPON THE INSURER, ITS AGENTS OR REPRESENTATIVES. AUTHORIZED REPRESENTATIVE Kelly Petzold/NANCR2
--	--



FFVA Mutual Insurance Co.

NCCI Co. No. 31321

Policy Number

WC840-0017609-2006A

1. INSURED:

Prior Policy Number

New

Transportation Control Systems, Inc.

909 3rd Street East

Palmetto, FL 34221

Federal ID Number 591673144

Producer:

Wyman, Green & Blalock, Inc.

PO Box 9029

Bradenton, FL 34206

Business Type Corporation

Risk ID Number 090917447

Other Named Insured:

Other Work Places See WCE-107

2. POLICY PERIOD: The Policy Period Is From: 4/1/2006 To 4/1/2007 12:01 A.M. Standard Time at The Insured Mailing Address

3. COVERAGES:

- A. Workers Compensation Insurance: Part One of the policy applies to the Workers Compensation Law of the states listed here: FL
- B. Employers Liability Insurance: Part Two of the policy applies to work in each state listed in item 3A. The limits of our liability under Part Two are:

Bodily Injury by Accident	\$ 1,000,000	each accident
Bodily Injury by Disease	\$ 1,000,000	policy limit
Bodily Injury by Disease	\$ 1,000,000	each employee
- C. Other States Insured: Part Three of the policy applies to the states, if any, listed here:
- D. This policy includes these endorsements and schedules:
See WCE-105

4. COVERAGES: The premium for this policy will be determined by our Manual of Rules, Classifications, Rates & Rating Plans. All information required below is subject to verification and change by audit.

Classifications	Code No.	Premium Basis Total Estimated Annual Remuneration	Rate Per \$100 of Remuneration	Estimated Annual Premium
-----------------	----------	---	--------------------------------	--------------------------

See WC 00 00 01 A

Minimum Premium: \$688 Deposit Premium: \$2,881

Interim Adjustment: Annually

Servicing Office:
P.O. Box 948239
Maitland, FL 32794-8239

Total Estimated Premium \$14,021

Issue Date 04/20/2006

Countersigned By:

Date

**TRANSPORTATION
CONTROL SYSTEMS**
TRAFFIC SIGNAL PRODUCTS
SALES AND SERVICE



1030 86th STREET • TAMPA, FLORIDA 33619

TEL. 813-630-2800 FAX. 813-630-2801

FACSIMILE TRANSMITTAL SHEET

TO:	Judy Cheves, Purchasing Agent	FROM:	Carole Robinson, Offic Mgr.
COMPANY:	Lee County	DATE:	2/28/07
FAX NUMBER:	239-344-5460	TOTAL NO. OF PAGES INCLUDING COVER:	4
PHONE NUMBER:		SENDER'S REFERENCE NUMBER:	
RE:	Quote Q-070204	YOUR REFERENCE NUMBER:	

URGENT FOR APPROVAL PLEASE COMMENT PLEASE REPLY PLEASE RECYCLE

NOTES/COMMENTS:

Following is a copy of Affidavit Cert. Immigration Laws with Notary Stamp and the Insurance Certificates for Liability and Workman's Comp. proof of insurance.

ATTACHMENT #4**Cheves, Judith E.**

From: Berens, Mike G.
Sent: Friday, February 02, 2007 11:30 AM
To: Cheves, Judith E.
Cc: Franceschini, Robert D.; Palmer, Scott; Flenniken, David B.
Subject: RE: PELCO QUOTE

Judy,

We recommend to award by line item. Since Temple only bid on partial and have 40 day delivery (We asked for 30 day) are they still eligible?

Why Action is Necessary:

Board approval is required because this expenditure will exceed \$50,000.

What Action Accomplishes:

Establishes competitive, fair market prices for the Pelco Products for the Department of Transportation. Estimated savings to the taxpayer is \$3,000.

Account String:

PD5410417500.504635

Michael Berens
 Traffic Superintendent
 Lee County Public Works, DOT, Traffic
 5650 Enterprise Pkwy.
 Ft. Myers, Fl. 33905
berensmg@leegov.com
 239-533-9500: Phone
 239-694-5730: Fax

From: Cheves, Judith E.
Sent: Wednesday, January 24, 2007 4:12 PM
To: Berens, Mike G.
Cc: Franceschini, Robert D.
Subject: PELCO QUOTE

1/25/07

Good afternoon....

attached, please find the tab sheets (overall and detailed) for your review. The quotes are on the way to you by interoffice mail. It appears, due to the way the specifications were written, that we can award as overall low quoter or award by line item. It is, of course, your choice. Once you have had the opportunity to review the attached materials, please let me know by return e-mail of your recommendation of award

I also need language covering "why the action is necessary" and "what the action accomplishes" to put on the blue sheet to the board as well as an account string number.

Unfortunately, we are on a short time frame as I will need to get the blue sheet to blue sheet tracking by 2/15 in order to get to the board meeting of 2-27. If we do this, the new quote will be in place prior to the old quote expiring. It is purchasings goal not to let an existing quote expire before the new quote is in place.

If you have any questions, or concerns, please do not hesitate to contact me.

2/22/2007