

PARKWAY AREA WITH SIDEWALK

(PLAN VIEW)

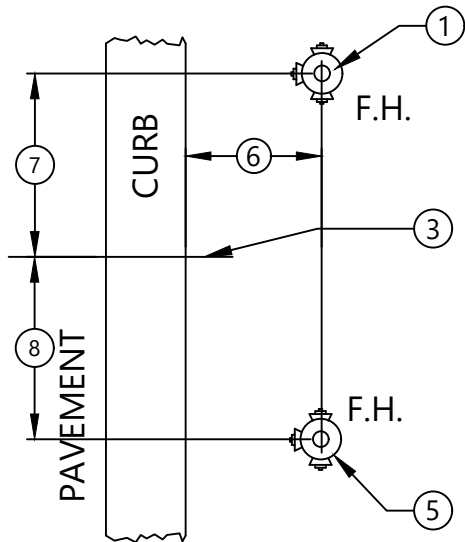

PARKWAY AREA OR NO SIDEWALK

(PLAN VIEW)

- ①. PREFERRED LOCATION
- ②. F.H. TO BE LOCATED 2' MINIMUM FROM EDGE OF SIDEWALK
- ③. P.T. OR P.C. OF CURB RETURN
- ④. PROPERTY LINE RIGHT-OF-WAY OR LIMIT OF EASEMENT
- ⑤. ACCEPTABLE LOCATION WITH CURB RADIUS OF 20' OR MORE
- ⑥. BETWEEN 5'-0" MIN. AND 10'-0" MAX.
- ⑦. 6'-0"
- ⑧. 4'-0"

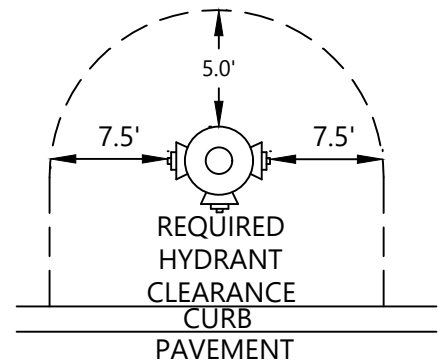

(PLAN VIEW)

NOTES:

1. OBSTRUCTIONS SUCH AS UTILITY POLES, STREET SIGNS, IRRIGATION BOXES, FENCES, ETC. SHALL NOT BE PLACED BETWEEN CURB AND HYDRANT.
2. SOME LOCATIONS APPLY AT EITHER END OF CURB RETURNS.
3. DIMENSIONS SHOWN ON CONSTRUCTION DRAWINGS SUPERCEDE LOCATIONS SHOWN HERE.

NOT TO SCALE

| | | |
|--|--|--|
|  | LEE COUNTY UTILITIES ENGINEERING <small>1500 MONROE STREET FORT MYERS, FLORIDA 33901</small> | |
| | TITLE: WATER PRESSURE LINE VERTICAL OFFSET W/DIP & MJ FITTINGS | |
| <small>REVISION:</small> 3/7/24 | <small>DETAIL NO:</small> W-13.dwg | |